

Voltage Controlled Oscillator 12.2 – 13.8 GHz

Preliminary: Rev. V2P

Features

- Low Phase Noise
- Wide Tuning Range
- Divide-by-Two Output
- Integrated Buffer Amplifier
- Excellent Temperature Stability
- +5V Bias Supply
- Lead-Free 5 mm 32-Lead PQFN Package
- 100% Matte Tin Plating over Copper
- Halogen-Free “Green” Mold Compound
- RoHS* Compliant and 260°C Reflow Compatible

Description

The MAOC-009270-PKG003 is an InGaP HBT-based voltage controlled oscillator for frequency generation. No external matching components are required. This VCO is easily integrated into a phase lock loop using the divide-by-two output. The extremely low phase noise makes this part ideal for many radio applications including high capacity digital radios.

The 5 mm PQFN package has a lead-free finish that is RoHS compliant and compatible with a 260°C reflow temperature. The package also features low lead inductance and an excellent thermal path. The MTTF is 1,000,000 hours at a 150°C junction temperature.

Primary Applications

- Point-to-Point Radio
- Point-to-Multipoint Radio
- Communications Systems
- Low Phase Noise Applications

Ordering Information

Part Number	Package
MAOC-009270-TR0500	Tape & Reel, 500 pieces
MAOC-009270-TR1000	Tape & Reel, 1000 pieces
MAOC-009270-SMB003	Sample Board

Block Diagram

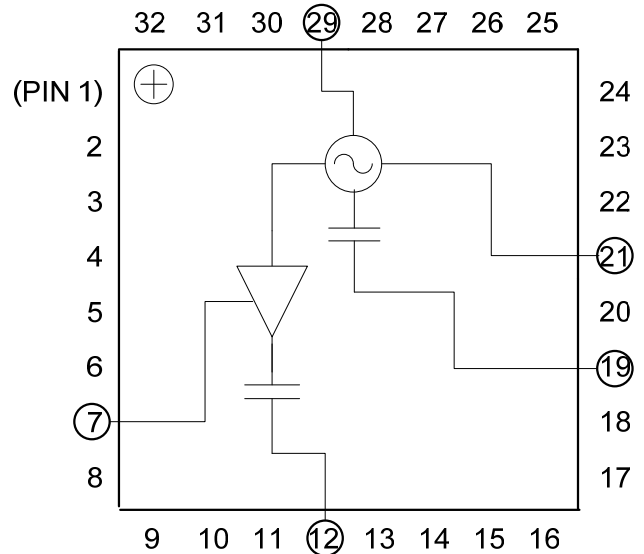

Pin Designations ¹

Pin	Function	Pin	Function
1	N/C	17	N/C
2	N/C	18	N/C
3	N/C	19	F _o
4	N/C	20	N/C
5	N/C	21	V _{CC}
6	N/C	22	N/C
7	V _{BUFFER}	23	N/C
8	N/C	24	N/C
9	N/C	25	N/C
10	N/C	26	N/C
11	N/C	27	N/C
12	F _{o/2}	28	N/C
13	N/C	29	V _{TUNE}
14	N/C	30	N/C
15	N/C	31	N/C
16	N/C	32	N/C

1. The exposed pad centered on the package bottom must be connected to RF and DC ground.

Voltage Controlled Oscillator 12.2 – 13.8 GHz

Preliminary: Rev. V2P

Electrical Specifications: $T_c = 25^\circ\text{C}$, $Z_L = 50 \Omega$, $V_{CC} = 5\text{V}$

Parameter		Min.	Typ.	Max.	Units
Frequency Range	Fo	12.2 - 13.8			GHz
	Fo/2	6.1 - 6.9			
Output Power across operating frequency range	RF Port		6.5		dBm
	RF/2 Port		5		
SSB Phase Noise $V_{CC} = V_{\text{buff}} = V_{\text{ctrl}} = 5\text{V}$	RF Port, 10KHz Offset		-75		dBc/Hz
	RF Port, 100KHz Offset		-105		
Tune Voltage	Vctrl	1		13	V
Supply Current	Icc + Ibuff		170		mA
Control Current Leakage	Vctl=13V		2		mA
Output Return Loss	RF Port		3		dB
	RF/2 Port		6		
Harmonics/Subharmonics $V_{CC} = V_{\text{buff}} = V_{\text{ctrl}} = 5\text{V}$	RF Port, 1/2Fo		18		dBc
	RF/2 Port, 2Fo		12.8		
Pulling (Sensitivity to Match)	RF Port, VSWR = 1.95:1 to 2.25:1 $V_{CC} = V_{\text{buff}} = V_{\text{ctrl}} = 5\text{V}$		17.6		MHz pk-pk
Pushing (Sensitivity to Supply Voltage)	RF Port		15		MHz/V
	RF/2 Port		1		
Frequency Drift Rate (Sensitivity to Temperature)	RF Port		1.2		MHz/°C
	RF/2 Port		0.6		

Absolute Maximum Ratings ^{2,3}

Parameter	Absolute Maximum
V_{CC} (VCO & Buffer)	+6V
Storage Temperature	-55°C to +150°C
Operating Temperature	-40°C to +85°C

- Exceeding any one or combination of these limits may cause permanent damage to this device.
- M/A-COM does not recommend sustained operation near these survivability limits.

Typical Supply Current

V_{CC} (Volt)	I_{VCO} (mA)	V_{buffer} (V)	I_{buffer} (mA)
5	130	5	40

Static Sensitivity

Gallium Arsenide Integrated Circuits are sensitive to **Electrostatic Discharge (ESD)** and can be damaged by static electricity. Proper ESD control techniques should be used when handling these devices.



ESD Rating: 200 Volts

Voltage Controlled Oscillator 12.2 – 13.8 GHz

Preliminary: Rev. V2P

Typical Performance Curves: $V_{CC} = 5V$, $T_A = +25^\circ C$ (unless otherwise indicated)

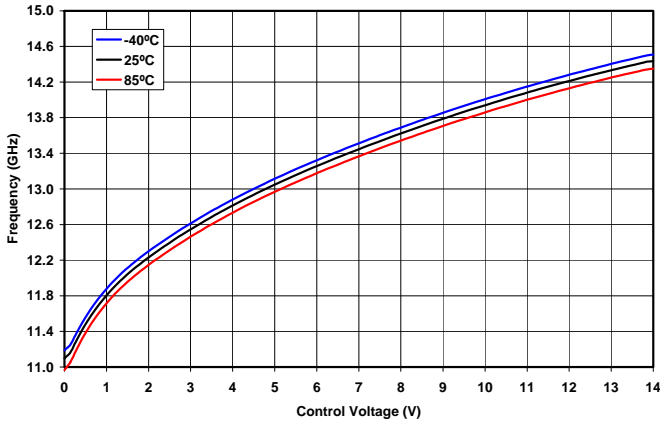

Figure 1: Frequency vs. Control Voltage and Temperature - RF Port

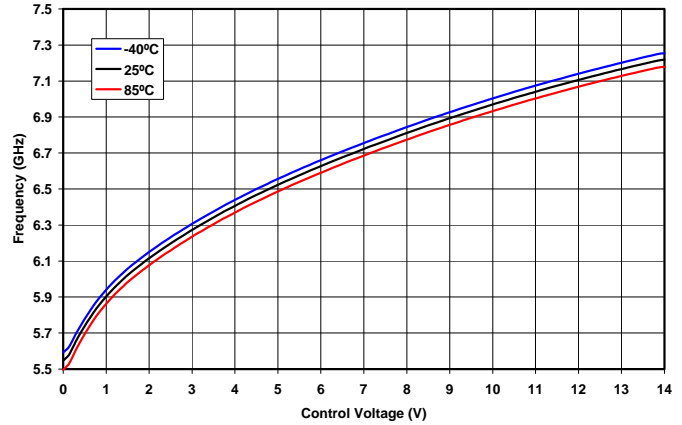

Figure 2: Frequency vs. Control Voltage and Temperature - RF/2 Port

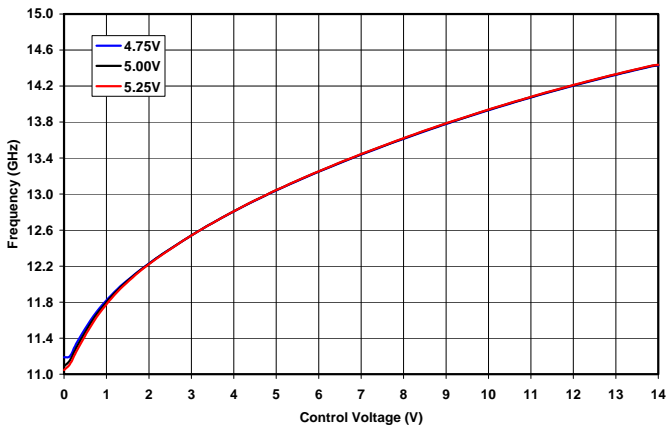

Figure 3: Frequency vs. Control Voltage and Supply Voltage - RF Port

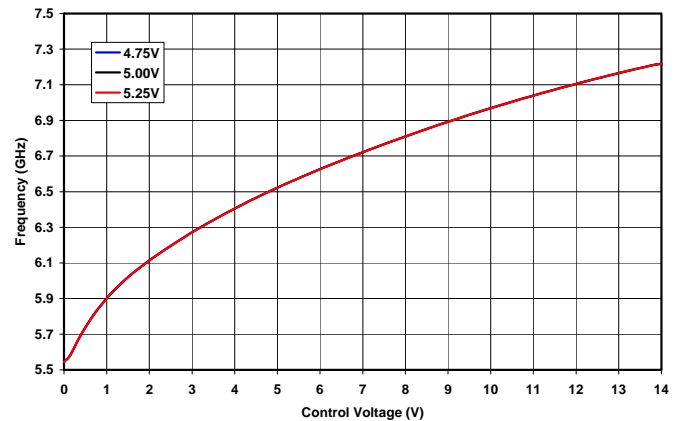

Figure 4: Frequency vs. Control Voltage and Supply Voltage - RF/2 Port

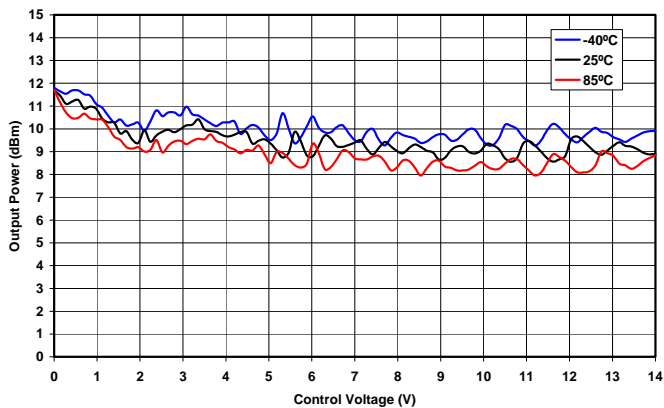

Figure 5: Output Power vs. Control Voltage and Temperature - RF Port

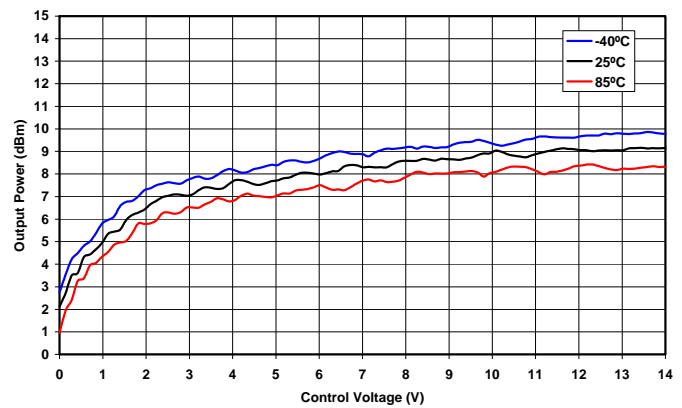

Figure 6: Output Power vs. Control Voltage and Temperature - RF/2 Port

3

ADVANCED: Data Sheets contain information regarding a product M/A-COM Technology Solutions is considering for development. Performance is based on target specifications, simulated results, and/or prototype measurements. Commitment to develop is not guaranteed.
PRELIMINARY: Data Sheets contain information regarding a product M/A-COM Technology Solutions has under development. Performance is based on engineering tests. Specifications are typical. Mechanical outline has been fixed. Engineering samples and/or test data may be available. Commitment to produce in volume is not guaranteed.

- **North America** Tel: 800.366.2266 / Fax: 978.366.2266
 - **Europe** Tel: 44.1908.574.200 / Fax: 44.1908.574.300
 - **Asia/Pacific** Tel: 81.44.844.8296 / Fax: 81.44.844.8298
- Visit www.macomtech.com for additional data sheets and product information.

M/A-COM Technology Solutions Inc. and its affiliates reserve the right to make changes to the product(s) or information contained herein without notice.

Typical Performance Curves: $V_{CC} = 5V$, $T_A = +25^\circ C$ (unless otherwise indicated)

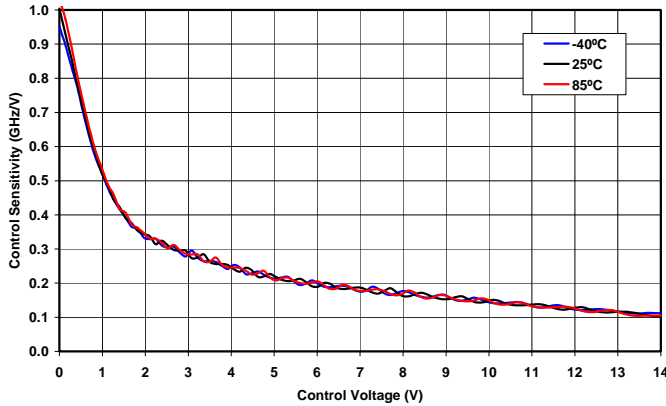

Figure 7: Frequency Sensitivity vs. Control Voltage and Temperature - RF Port

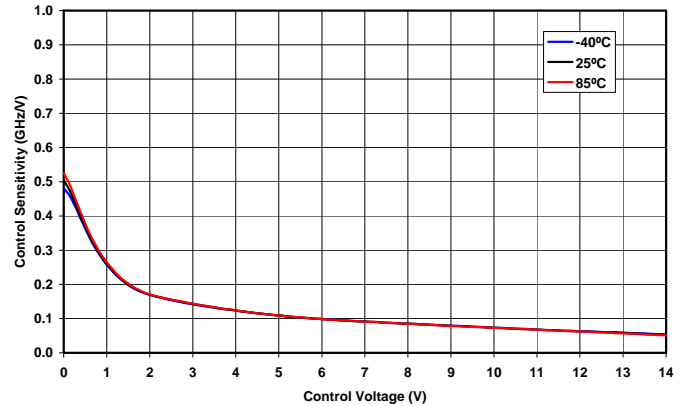

Figure 8: Frequency Sensitivity vs. Control Voltage and Temperature - RF/2 Port

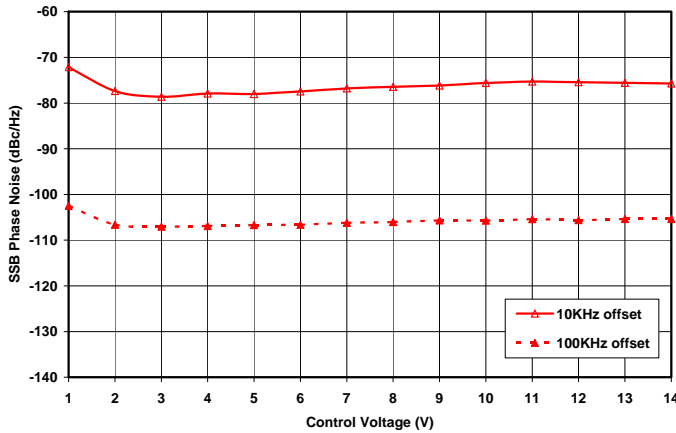

Figure 9: Single Side Band Phase Noise vs. Control Voltage and Offset Frequency

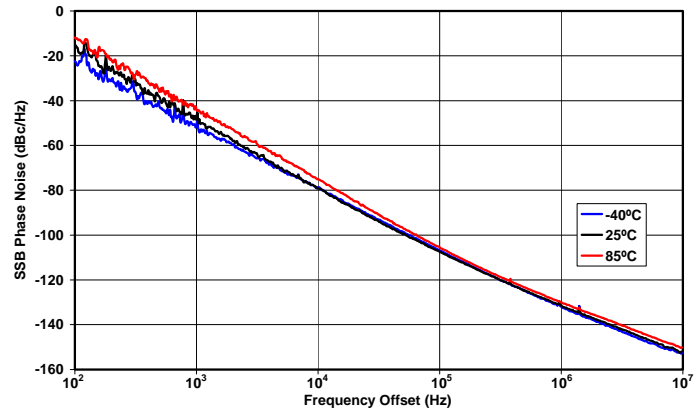

Figure 10: Single Side Band Phase Noise vs. Frequency Offset (Vctrl = 5V)

MAOC-009270 -PKG003



Voltage Controlled Oscillator
12.2 – 13.8 GHz

Preliminary: Rev. V2P

Lead Free 5mm 32-Lead PQFN

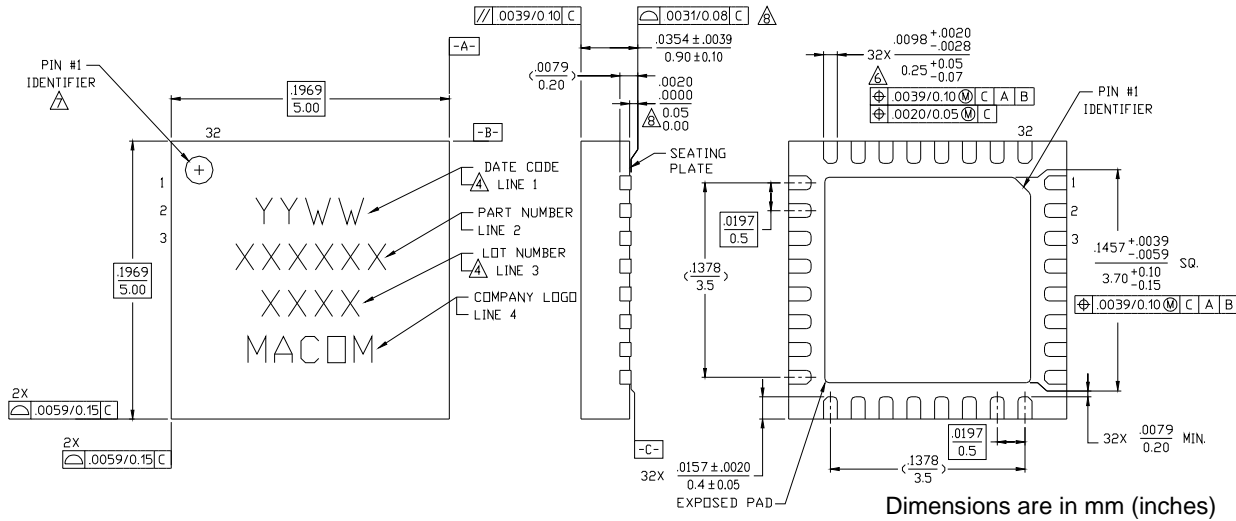

Sample Board

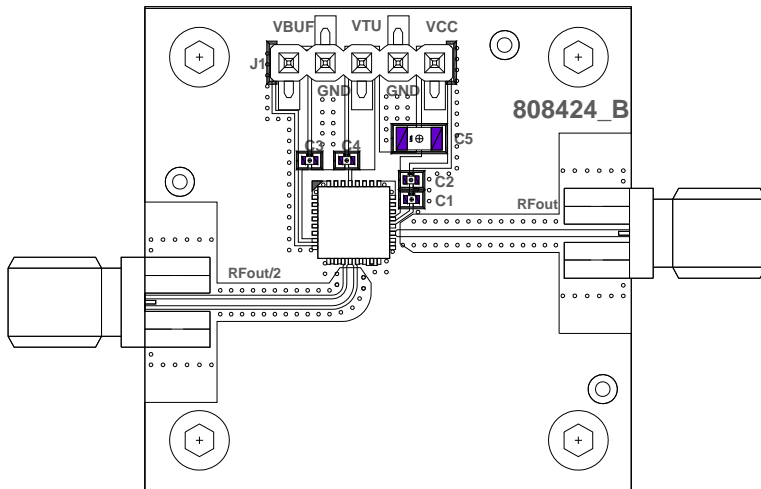

Component	Value	Case Size	Manufacturer
C1, C3, C4	100 pF	0402	Murata
C2	0.1 μ F	0402	Murata
C5	10 μ F	1206	AVX

ADVANCED: Data Sheets contain information regarding a product M/A-COM Technology Solutions is considering for development. Performance is based on target specifications, simulated results, and/or prototype measurements. Commitment to develop is not guaranteed.
PRELIMINARY: Data Sheets contain information regarding a product M/A-COM Technology Solutions has under development. Performance is based on engineering tests. Specifications are typical. Mechanical outline has been fixed. Engineering samples and/or test data may be available. Commitment to produce in volume is not guaranteed.

- **North America** Tel: 800.366.2266 / Fax: 978.366.2266
- **Europe** Tel: 44.1908.574.200 / Fax: 44.1908.574.300
- **Asia/Pacific** Tel: 81.44.844.8296 / Fax: 81.44.844.8298

Visit www.macomtech.com for additional data sheets and product information.

M/A-COM Technology Solutions Inc. and its affiliates reserve the right to make changes to the product(s) or information contained herein without notice.