

Description

GM2576 series is designed to provide all the active function for a step-down (buck) switching regulator, and drives a maximum load current as high as 2A line and load regulations. GM2576 is available in fixed output voltages of 3.3V, 5V, and a versatile Adjustable output version.

These regulators are simple to use and require minimum number of external components. The features include internal frequency compensation and a fixed-frequency oscillator.

The GM2576 is high-efficiency replacements for popular three-terminal linear regulators, and is requiring a smaller heat sink or even no need heat sink.

GM2576 performs well with standard inductors from most of manufacturers, and simplifying the design of switch-mode power supplies. External shutdown is included with 80 μ A (typical) standby current. The output switch has cycle-by-cycle current limiting as well as thermal shutdown for full protection under fault conditions.

GM2576 operates at a switching frequency of 52 kHz which allowing smaller size filter components than what would be needed with lower frequency switching regulators.

GM2576 series are available in a standard 8-lead SO package, 8 lead SO package with heat sink or 5L TO252 package.

Features

- ◆ Standard SOP8 & PSOP8 and 5L TO252 packages are available
- ◆ 3.3V, 5V, and Adjustable output versions
- ◆ Adjustable version output voltage range 1.23V to 37V
- ◆ V_{OUT} accuracy is to $\pm 1.8\%$ under specified input voltage and output load conditions
- ◆ Input voltage range up to 40V
- ◆ Requires only 4 external components with High efficiency
- ◆ TTL shutdown capability, low power standby mode
- ◆ Built-in thermal shutdown, current limit protection
- ◆ Uses standard inductors
- ◆ 52 kHz fixed frequency internal oscillator

Application

Pre-regulator for linear regulators

On-card/board switching regulators

High-efficiency step-down buck regulator

Positive to negative converter (buck-boost)

Typical Application Circuits

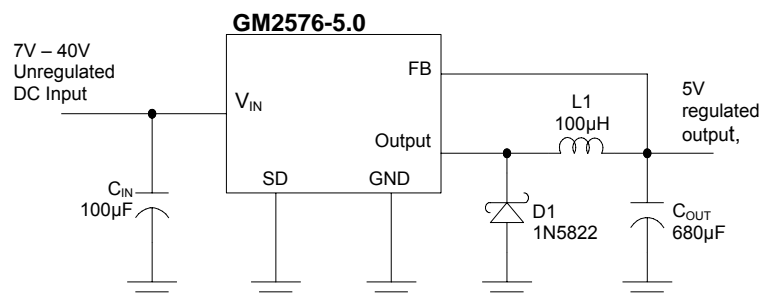

Marking Information and Pin Configurations (Top View)

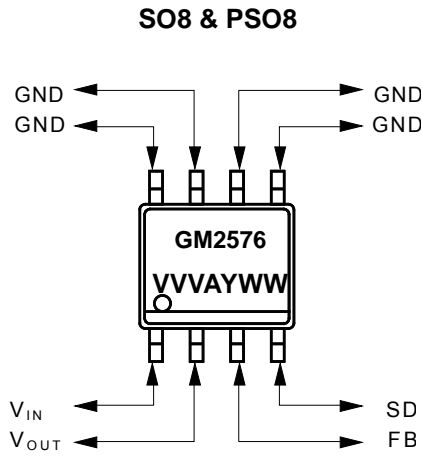

VVV: 033=3.3V, 050=5.0V, 00A=ADJ
 A: Assembly / Testing factory code
 Y: Year
 WW: Week

5L TO-252

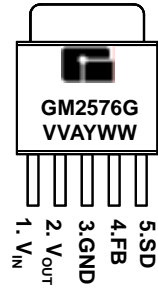

VV: 33=3.3V, 50=5.0V, A=ADJ
 A: Assembly / Testing factory code
 Y: Year
 WW: Week

Ordering Information

Ordering Number	Output Voltage	Package	Shipping
GM2576-AS8T	Adj	SOP8	100 Units / Tube
GM2576-AS8R	Adj	SOP8	2500 Units / Reel
GM2576-APS8T	Adj	PSOP8	100 Units / Tube
GM2576-APS8R	Adj	PSOP8	2500 Units / Reel
GM2576-ATC5RG	Adj	5L-TO252	50 Units / Tube
GM2576-3.3S8T	3.3	SOP8	100 Units / Tube
GM2576-3.3S8R	3.3	SOP8	2500 Units / Reel
GM2576-3.3PS8T	3.3	PSOP8	100 Units / Tube
GM2576-3.3PS8R	3.3	PSOP8	2500 Units / Reel
GM2576-3.3TC5RG	3.3	5L-TO252	50 Units / Tube
GM2576-5.0S8T	5.0	SOP8	100 Units / Tube
GM2576-5.0S8R	5.0	SOP8	2500 Units / Reel
GM2576-5.0PS8T	5.0	PSOP8	100 Units / Tube
GM2576-5.0PS8R	5.0	PSOP8	2500 Units / Reel
GM2576-3.3TC5RG	5.0	5L-TO252	50 Units / Tube

Absolute Maximum Ratings (Note 1)

Rating	Value	Unit
Maximum Supply Voltage	45	V
SD Pin Input Voltage / Feed Back Pin Voltage	$-0.3 + V_{IN} + 0.3$	V
Output Voltage to Ground (Steady State)	$-0.3 + V_{IN} + 0.3$	V
Power Dissipation	Internally Limited	-
Thermal Resistance – Junction to Ambient (θ_{JA}) ** 2 square inch of FR-4, double sided, 1oz. minimum copper weight, is recommended	36	/W
Storage Temperature Range	- 65 to 150	
Maximum Junction Temperature	+ 150	
Operating Temperature Range	- 40 to 125	
Minimum EDS Rating (Note 2)	2	kV
Lead Temperature (Soldering, 10 sec)	+ 260	

Block Diagram

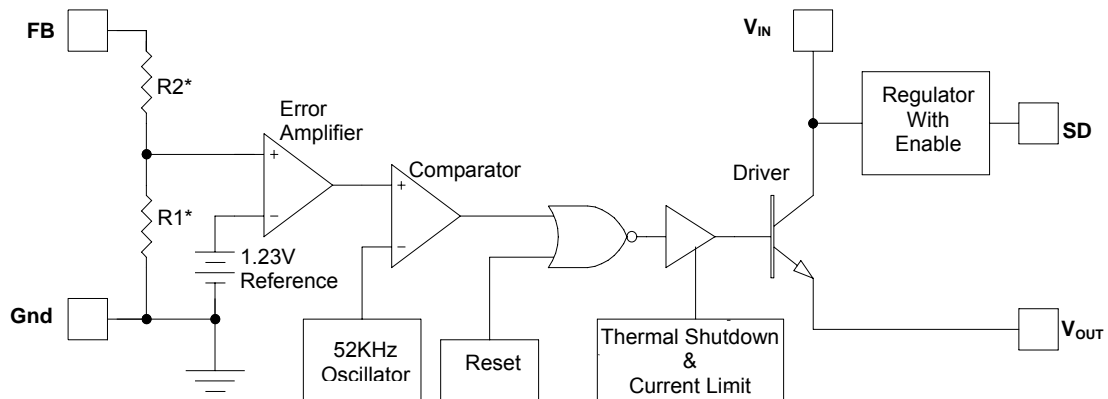

$V_{OUT} = 3.3V, R1 = 2.49K, R2 = 4.18K$
 $V_{OUT} = 5.0V, R1 = 2.49K, R2 = 7.57K$
 $V_{OUT} = ADJ, R1 = OPEN, R2 = 0\Omega$

Electrical Characteristics: GM2576-ADJ

(Specifications with standard type face are for $T = 25^\circ\text{C}$, and those with bold face type apply over full Operating Temperature range)

Parameter	Condition	Symbol	Min	Typ	Max	Unit
Feedback Voltage	$V_{IN} = 12\text{V}$, $I_{LOAD} = 0.2\text{A}$, V_{OUT} is set to 5V	V_{FB}	1.217	1.230	1.243	V
	$4.5\text{V} \leq V_{IN} \leq 40\text{V}$, $0.2\text{A} \leq I_{LOAD} \leq 2\text{A}$, V_{OUT} is set to 5V		1.208	1.230	1.252	
			1.180		1.280	
Efficiency	$V_{IN} = 12\text{V}$, $I_{LOAD} = 2.0\text{A}$, $V_{OUT} = 5\text{V}$	η		77		%

Electrical Characteristics: GM2576-3.3

(Specifications with standard type face are for $T = 25^\circ\text{C}$, and those with bold face type apply over full Operating Temperature range)

Parameter	Condition	Symbol	Min	Typ	Max	Unit
Output Voltage	$4.5\text{V} \leq V_{IN} \leq 40\text{V}$, $0.2\text{A} \leq I_{LOAD} \leq 2\text{A}$	V_{OUT}	3.163	3.300	3.390	V
			3.201		3.432	
Efficiency	$V_{IN} = 12\text{V}$, $I_{LOAD} = 2.0\text{A}$	η		73		%

Electrical Characteristics: GM2576-5.0

(Specifications with standard type face are for $T = 25^\circ\text{C}$, and those with bold face type apply over full Operating Temperature range)

Parameter	Condition	Symbol	Min	Typ	Max	Unit
Output Voltage	$4.5\text{V} \leq V_{IN} \leq 40\text{V}$, $0.2\text{A} \leq I_{LOAD} \leq 2\text{A}$	V_{OUT}	4.850	5.000	5.150	V
			4.800		5.200	
Efficiency	$V_{IN} = 12\text{V}$, $I_{LOAD} = 2.0\text{A}$	η		77		%

Electrical Characteristics: All Output Voltage Versions

(Specifications with standard type face are for T = 25 °C, and those with bold face type apply over full Operating Temperature range)

Parameter	Condition	Symbol	Min	Typ	Max	Unit
Feedback Bias Current	V _{FB} = 5V (Adjustable Version Only)	I _b	-	50	100	nA
					500	
Oscillator Frequency	(Note 3)	f _o	42	52	58	kHz
Saturation Voltage	I _{OUT} = 2A (Notes 4, 5)	V _{SAT}	-	1.4	1.8	V
					2.0	
Max Duty Cycle (ON)	(Note 5)	DC	93	98	-	%
Current Limit	Peak Current (Notes 4, 5)	I _{CL}	3.6	4.5	6.9	A
			3.4		7.5	
Output Leakage Current	Output = 0V (Notes 4, 6)	I _L	-	7.5	2	mA
	Output = -1V (Notes 4, 6)				30	
Quiescent Current	(Note 6)	I _Q	-	5	10	mA
Standby Quiescent Current	SD Pin = 5V (OFF)	I _{STBY}	-	50	200	μA
SD Pin Logic Input Level	Low (ON)	V _{IH}	-	1.2	1.0	V
	High (OFF)	V _{IL}	2.2	1.4	-	
			2.4			
SD Pin Input Current	V _{LOGIC} = 2.5V (OFF)	I _H		12	30	μA
	V _{LOGIC} = 0.5V (ON)	I _L		0	10	

Note 1: Stresses greater than those listed under Maximum Ratings may cause permanent damage to the device. This is a stress rating only and functional operation of the device at these or any other conditions above those indicated in the operation is not implied. Exposure to absolute maximum rating conditions for extended periods may affect reliability.

Note 2: The human body model is a 100pF capacitor discharge through a 1.5KΩ resistor into each pin.

Note 3: External components such as the catch diode, inductor, input and output capacitors, and voltage programming resistors can affect switching regulator system performance. Where the GM2576 is used as shown in Figure 1&2 test circuits.

Note 4: No diode, inductor or capacitor connected to output pin.

Note 5: Feedback pin removed from output and connected to 0V to force the output transistor switch ON.

Note 6: Feedback pin removed from output and connected to 12V for the 3.V, 5V and Adj version, to force the output transistor switch OFF.

Test Circuit and Layout Guidelines

Careful layout is important with any switching regulators. Rapidly switching currents associated with wiring inductance generate voltage transients which can cause problems. To minimize inductance and ground loops, the lengths of the leads indicated by heavy lines in Figure 1&2 below should be kept as short as possible. Single point grounding (as indicated or ground plane construction should be used for best results. When using the Adjustable version, place the programming resistors as close as possible to GM2576, to keep the sensitive feedback wiring short.

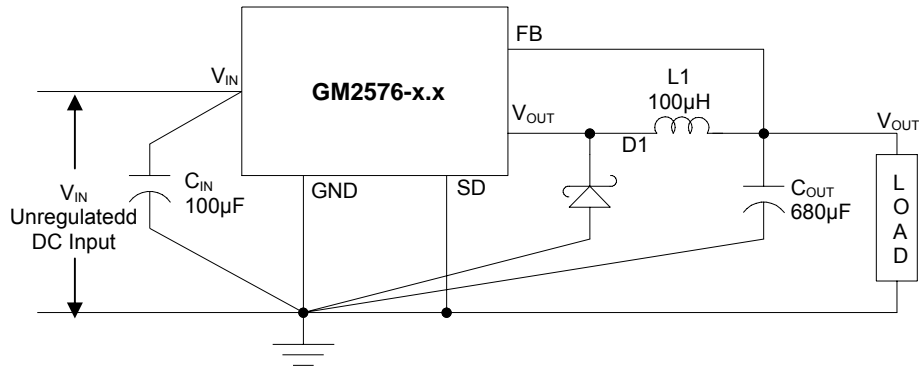

Figure 1 Fixed Output Voltage Versions

$C_{IN} = 100\mu\text{F}$, Aluminum Electrolytic
 $C_{OUT} = 680\mu\text{F}$, 25V, Aluminum Electrolytic
 D1 = Schottky
 L1 = 100µH

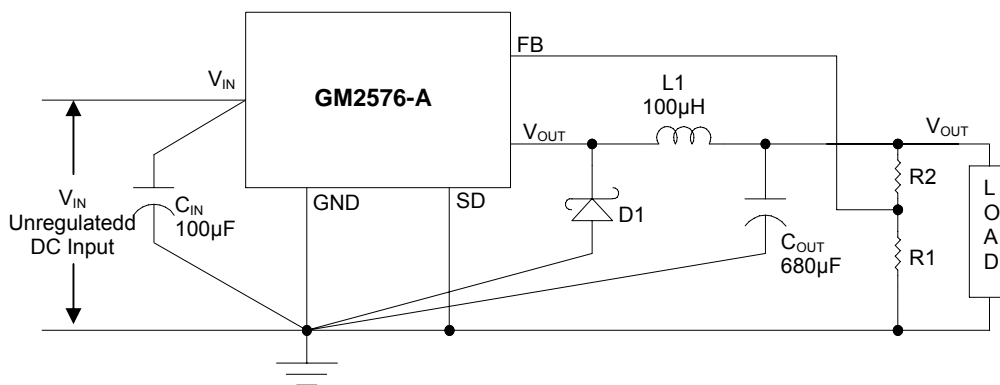

Figure 2 Adjustable Output Voltage Versions

$C_{IN} = 100\mu\text{F}$, Aluminum Electrolytic
 $C_{OUT} = 680\mu\text{F}$, 25V, Aluminum Electrolytic
 D1 = Schottky
 L1 = 100µH

$$V_{OUT} = V_{REF} (1 + R2/R1)$$

where $V_{REF} = 1.23\text{V}$ and R1 is between 1K to 5K

Package Outline Dimensions – SO 8

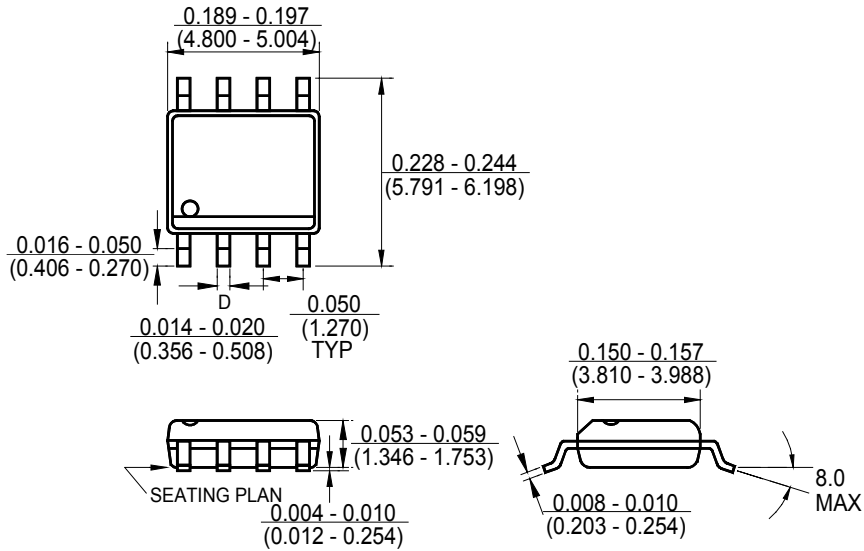

Package Outline Dimensions – PSO 8

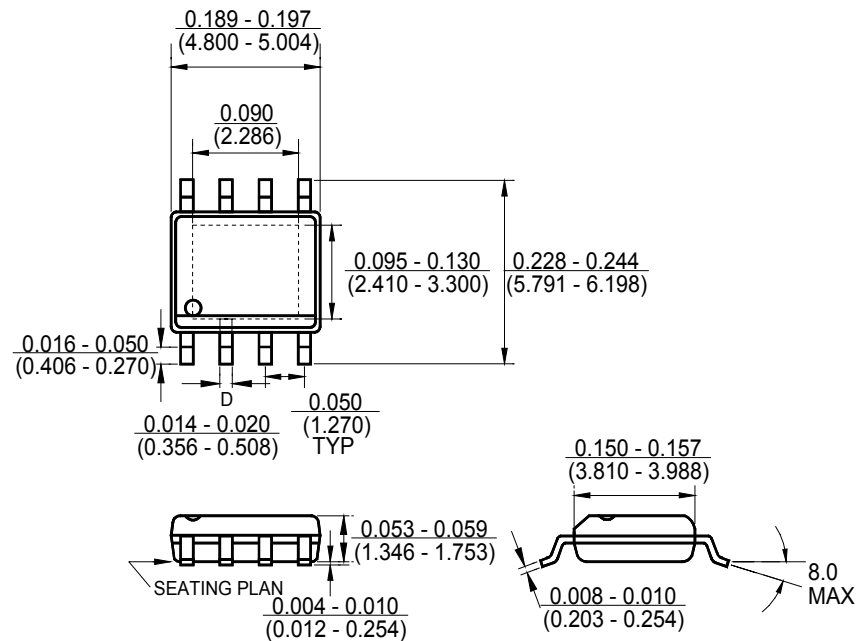

Package Outline Dimensions – 5L TO252

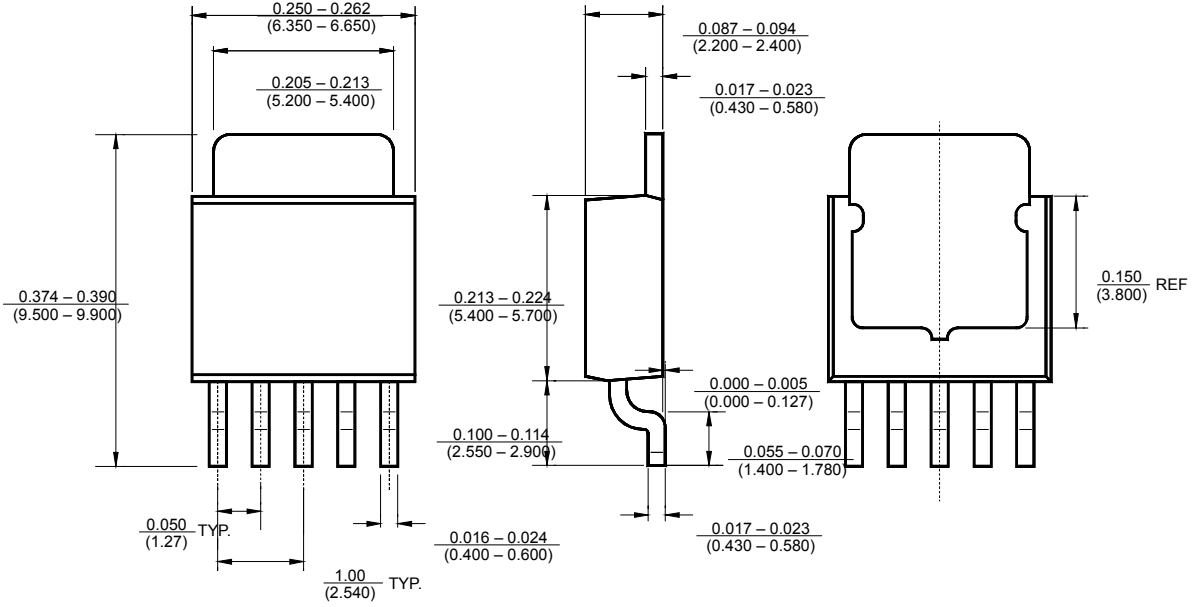

Ordering Number

GM 2576 A S8 R

APM Gamma Micro	Circuit Type	Output Voltage A: Adj 3.3 = 3.3V 5.0 =5.0V	Package Type S8: SO 8 PS8: Power SO 8 TA5: 5L TO252	Shipping Type R: Taping & Reel T: Tube
--------------------	--------------	-----------------------------------------------------	--------------------------------------------------------------	----------------------------------------------