

Silicon NPN Power Transistors

2SC1449

DESCRIPTION

- With TO-126 package
- Low collector saturation voltage

APPLICATIONS

- Low frequency power amplification
- High frequency amplification

PINNING

PIN	DESCRIPTION
1	Emitter
2	Collector
3	Base

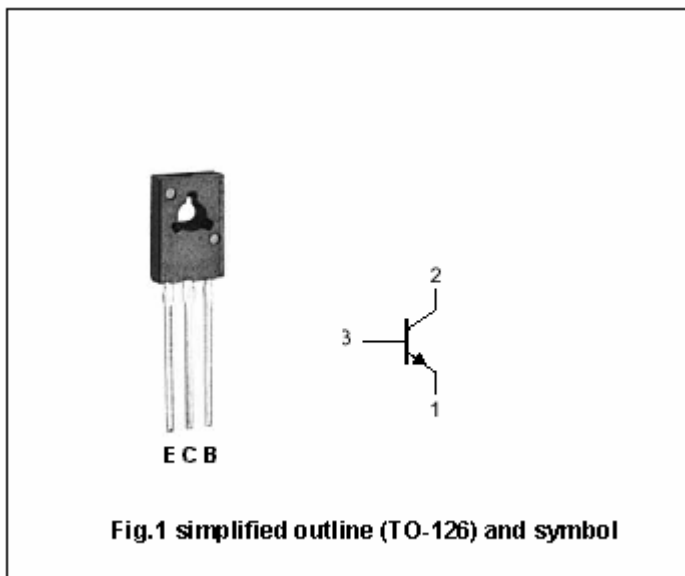

Absolute maximum ratings (Ta=25°C)

SYMBOL	PARAMETER	CONDITIONS	VALUE	UNIT
V _{CBO}	Collector-base voltage	Open emitter	40	V
V _{CEO}	Collector-emitter voltage	Open base	35	V
V _{EBO}	Emitter-base voltage	Open collector	5	V
I _C	Collector current		2	A
I _B	Base current		1	A
P _C	Collector power dissipation	T _a =25°C	1.0	W
		T _C =25°C	10	
T _j	Junction temperature		150	°C
T _{stg}	Storage temperature		-55~150	°C

Silicon NPN Power Transistors

2SC1449

CHARACTERISTICS

T_j=25 °C unless otherwise specified

SYMBOL	PARAMETER	CONDITIONS	MIN	TYP.	MAX	UNIT
V _{(BR)CBO}	Collector-base breakdown voltage	I _C =100μA; I _E =0	40			V
V _{(BR)CEO}	Collector-emitter breakdown voltage	I _C =10mA; I _B =0	35			V
V _{(BR)EBO}	Emitter-base breakdown voltage	I _E =100μA; I _C =0	5			V
V _{CEsat}	Collector-emitter saturation voltage	I _C =500mA ; I _B =50m A			0.7	V
V _{BEsat}	Base-emitter saturation voltage	I _C =500mA ; I _B =50m A			1.5	V
h _{FE}	DC current gain	I _C =300mA ; V _{CE} =2V	40		250	
I _{CBO}	Collector cut-off current	V _{CB} =35V; I _E =0			0.5	μA
I _{EBO}	Emitter cut-off current	V _{EB} =4V; I _C =0			0.5	μA
C _{OB}	Output capacitance	I _E =0; V _{CB} =10V; f=1MHz		20		pF
f _T	Transition frequency	I _C =100mA ; V _{CE} =5V		55		MHz

Silicon NPN Power Transistors

2SC1449

PACKAGE OUTLINE

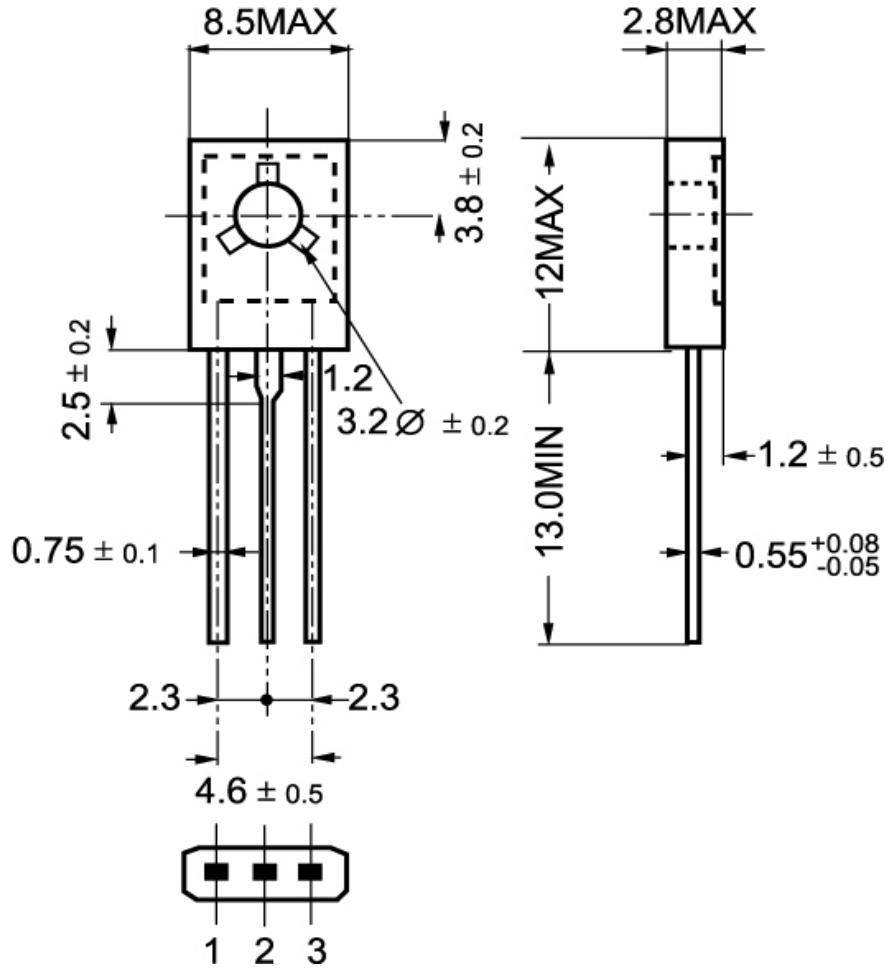

Fig.2 outline dimensions