

isc Silicon PNP Power Transistor

2SA1452

DESCRIPTION

- Low Collector Saturation Voltage-  
:  $V_{CE(sat)} = -0.4V(Max) @ I_C = -6A$
- Good Linearity of  $h_{FE}$
- High Switching Speed
- Complement to Type 2SC3710

APPLICATIONS

- Designed for high current switching applications

ABSOLUTE MAXIMUM RATINGS( $T_a=25^{\circ}C$ )

SYMBOL	PARAMETER	VALUE	UNIT
$V_{CBO}$	Collector-Base Voltage	-80	V
$V_{CEO}$	Collector-Emmitter Voltage	-80	V
$V_{EBO}$	Emitter-Base Voltage	-6	V
$I_C$	Collector Current-Continuous	-12	A
$I_B$	Base Current-Continuous	-2	A
$P_C$	Collector Power Dissipation @ $T_C=25^{\circ}C$	30	W
$T_J$	Junction Temperature	150	$^{\circ}C$
$T_{stg}$	Storage Temperature Range	-55~150	$^{\circ}C$

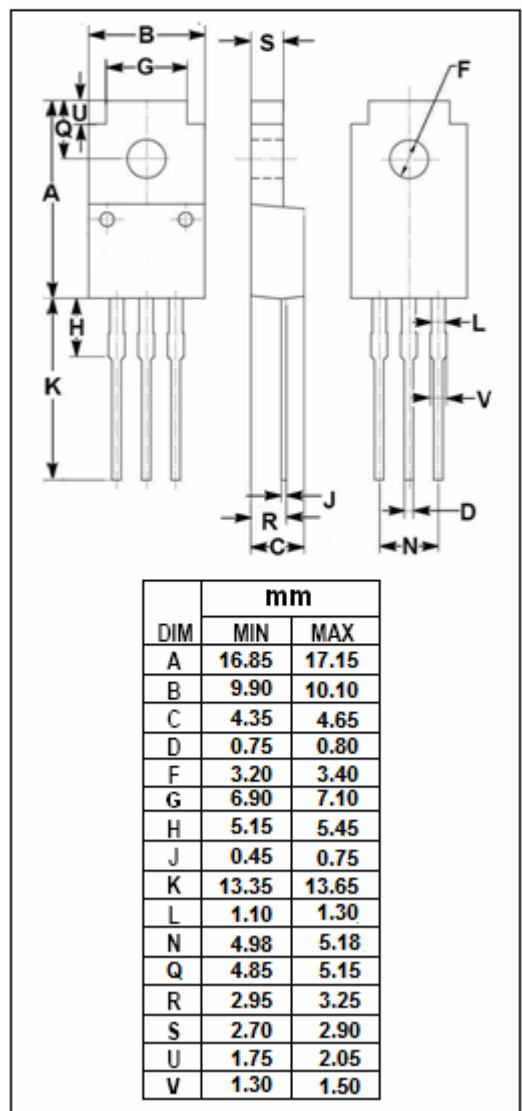
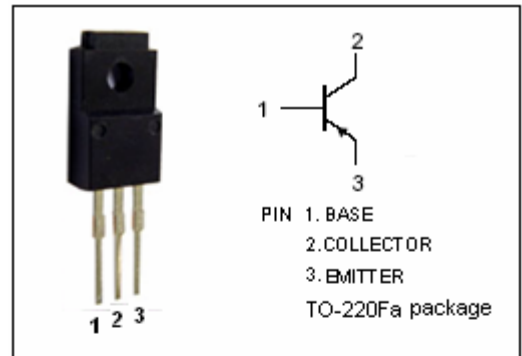

## isc Silicon PNP Power Transistor

2SA1452

## ELECTRICAL CHARACTERISTICS

 $T_C=25^\circ\text{C}$  unless otherwise specified

SYMBOL	PARAMETER	CONDITIONS	MIN	TYP.	MAX	UNIT
$V_{(BR)CEO}$	Collector-Emitter Breakdown Voltage	$I_C = -50\text{mA}$ ; $I_B = 0$	-80			V
$V_{CE(sat)}$	Collector-Emitter Saturation Voltage	$I_C = -6\text{A}$ ; $I_B = -0.3\text{A}$			-0.4	V
$V_{BE(sat)}$	Base-Emitter Saturation Voltage	$I_C = -6\text{A}$ ; $I_B = -0.3\text{A}$			-1.2	V
$I_{CBO}$	Collector Cutoff Current	$V_{CB} = -80\text{V}$ ; $I_E = 0$			-10	$\mu\text{A}$
$I_{EBO}$	Emitter Cutoff Current	$V_{EB} = -6\text{V}$ ; $I_C = 0$			-10	$\mu\text{A}$
$h_{FE-1}$	DC Current Gain	$I_C = -1\text{A}$ ; $V_{CE} = -1\text{V}$	70		240	
$h_{FE-2}$	DC Current Gain	$I_C = -6\text{A}$ ; $V_{CE} = -1\text{V}$	40			
$C_{OB}$	Output Capacitance	$I_E = 0$ ; $V_{CB} = -10\text{V}$ ; $f_{test} = 1\text{MHz}$		400		pF
$f_T$	Current-Gain—Bandwidth Product	$I_C = -1\text{A}$ ; $V_{CE} = -5\text{V}$		50		MHz

## Switching Times

$t_{on}$	Turn-on Time	$I_C = -6\text{A}$ , $I_{B1} = -I_{B2} = -0.3\text{A}$ , $V_{CC} = -30\text{V}$ , $R_L = 5\Omega$		0.3		$\mu\text{s}$
$t_{stg}$	Storage Time			1.0		$\mu\text{s}$
$t_f$	Fall Time			0.5		$\mu\text{s}$

◆  $h_{FE-1}$  Classifications

O	P
70-140	120-240