



Product information presented is current as of publication date. Details are subject to change without notice

CONSTANT CURRENT BOOST CONVERTER FOR 1 TO 4 WHITE LEDS

FEATURES

- Up to 4 LEDs at 2.8V Supply
- High Efficiency (85%)
- Output Over Voltage Protection
- HV Internal Switch
- 1 MHz PWM Switching Frequency
- Uses Tiny 1 mm Height Inductor
- 2.6V to 6V Input Range
- 0.1µA Shutdown Current
- SOT23-5 , SOT23-6, TSOT23-6, and VSON8 Packages Available

APPLICATIONS

- Palmtops
- MP3 Player
- Digital Still Cameras
- Portable Media Player
- Cell Phones and Smart Phones
- Electronic Information Organizers

TYPICAL APPLICATION

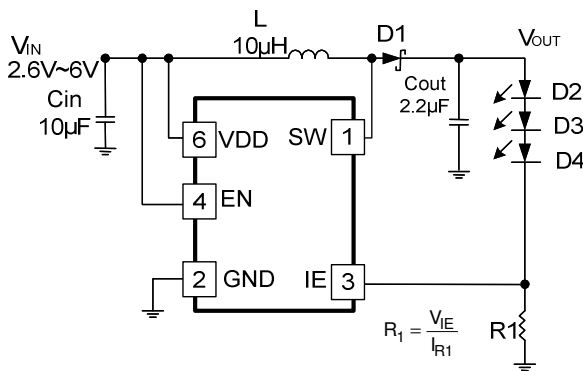

GENERAL DESCRIPTION

The AAT1500 is a step-up converter that provides a solution to drive 1 to 4 white LEDs with a constant current from a lithium cell, and its switching frequency is fixed at 1 MHz.

The AAT1500 offers a low 0.25V reference, which minimizes power loss in the current setting resistor and improves efficiency. Except in SOT23-5 package, protection features include output over voltage protections. The AAT1500 consists of a 0.1µA shutdown current, and HV internal switch. Input supply range allows operation from 2.6V to 6V.

The AAT1500 is available in SOT23-5, SOT23-6, TSOT23-6 and VSON8 packages.

PIN CONFIGURATION

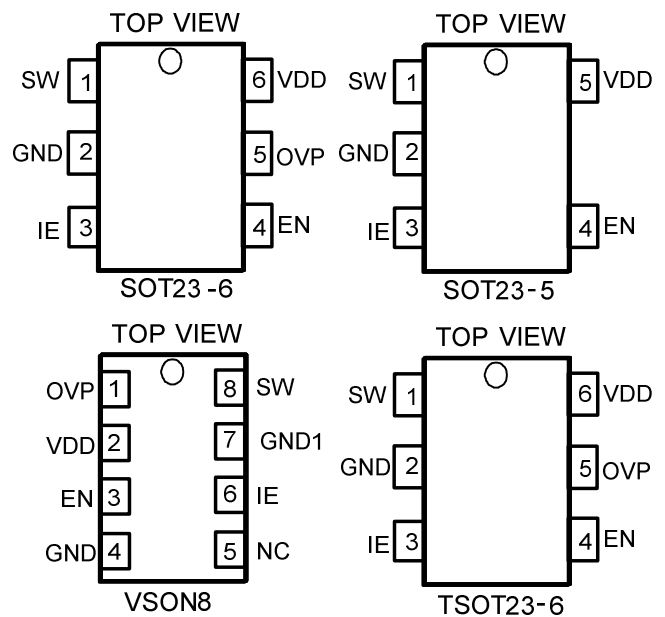



ORDERING INFORMATION

DEVICE TYPE	PART NUMBER	PACKAGE	PACKING	TEMP. RANGE	MARKING	MARKING DESCRIPTION
AAT1500	AAT1500-S5-T	S5:SOT 23-5 (SOT25)	T: Tape and Reel	-40 °C to 85 °C	1500	Device Type
AAT1500	AAT1500-S3-T	S3:SOT 23-6 (SOT26)	T: Tape and Reel	-40 °C to 85 °C	1500	Device Type
AAT1500	AAT1500-S13-T	S13:TSOT 23-6 (TSOT26)	T: Tape and Reel	-40 °C to 85 °C	1500	Device Type
AAT1500	AAT1500-Q6-T	Q6:VSON 8-2.2*2.2	T: Tape and Reel	-40 °C to +85 °C	1500	Device Type

ABSOLUTE MAXIMUM RATINGS

CHARACTERISTICS	SYMBOL	VALUE	UNIT
Supply Voltage	V_{DD}	-0.3 to 7	V
SW, OVP to GND		-0.3 to 21	V
Other I/O Pin Voltage		-0.3 to 6	V
Junction Temperature		125	°C
Storage Temperature Range	$T_{STORAGE}$	-45 °C to +125 °C	°C
Operating Temperature Range	T_C	-40 °C to +85 °C	°C
Lead Temperature	T_L	260 °C	°C

Note: Stresses beyond those listed under “Absolute Maximum Ratings” may cause permanent damage to the device. Exposure to absolute maximum rating conditions for extended period of time may affect device reliability.

RECOMMENDED OPERATING CONDITIONS

CHARACTERISTICS	SYMBOL	VALUE	UNIT
Supply Voltage	V_{DD}	2.6 to 6	V



DISSIPATION RATINGS

CHARACTERISTICS	PACKAGE	SYMBOL	VALUE	UNIT
Package Thermal Resistance	SOT23-6	θ_{JA}	208	$^{\circ}\text{C}/\text{W}$
	VSON8	θ_{JA}	50	$^{\circ}\text{C}/\text{W}$
Power Dissipation, $T_C = 25^{\circ}\text{C}$	SOT23-6	P_d	0.48	W
	VSON8	P_d	2	W

ELECTRICAL CHARACTERISTICS

($V_{DD} = 3.6\text{ V}$, $T_C = 25^{\circ}\text{C}$, unless otherwise specified.)

Operating Condition

PARAMETER	SYMBOL	TEST CONDITION	MIN	TYP	MAX	UNIT
Supply Voltage	V_{DD}		2.6		4.5	V
Under Voltage Lockout	V_{UVLO}		1.8	2.2	2.3	V
Operating Current	I_{DD}	$V_{DD} = 5.5\text{V}$, Switch on			2	mA
Quiescent Current	I_Q	$V_{DD} = 5.5\text{V}$ $V_{FB} = 1.3\text{V}$, Switch off		250	500	μA
Shutdown Current	I_{SD}	$V_{DD} = 5.5\text{V}$, $V_{EN} < 0.4\text{V}$		0.1	1	μA

Oscillator

PARAMETER	SYMBOL	TEST CONDITION	MIN	TYP	MAX	UNIT
Operating Frequency	f_{OSC}		0.8	1.0	1.2	MHz
Maximum Duty Cycle	D_{MAX}		79	85	92	%

Reference Voltage

PARAMETER	SYMBOL	TEST CONDITION	MIN	TYP	MAX	UNIT
Feedback Voltage	V_{IE}	Note	0.237	0.250	0.263	V

Note: To measure the feedback voltage, the device V_{IE} would connect to the application circuit. The inductance is $10\ \mu\text{H}$ and the output voltage equals 12V .



ELECTRICAL CHARACTERISTICS

($V_{DD} = 3.6\text{ V}$, $T_C = 25^\circ\text{C}$, unless otherwise specified.)

N-Channel Switch

PARAMETER	SYMBOL	TEST CONDITION	MIN	TYP	MAX	UNIT
Current Limit	I_{LIM}		0.60	0.75	0.90	A
On-Resistance	R_{ON}		0.50	0.75	1.00	Ω
Leakage Current	I_{SWOFF}	$V_{SW} = 12\text{V}$		0.01	20.0	μA

Control and Protection

PARAMETER	SYMBOL	TEST CONDITION	MIN	TYP	MAX	UNIT
EN pin Current	I_{EN}			4	6	μA
OVP Threshold	V_{OVP}		14.5	15.5	20.0	V
Chip Enable/Disable	V_{ENH}	Chip Enable		0.8	1.4	V
	V_{ENL}	Chip Disable	0.4	0.8		V



TYPICAL OPERATING CHARACTERISTICS

Typical Application

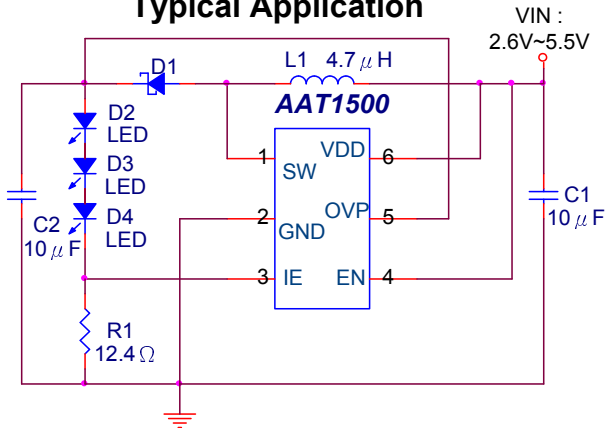

Efficiency vs. V_o

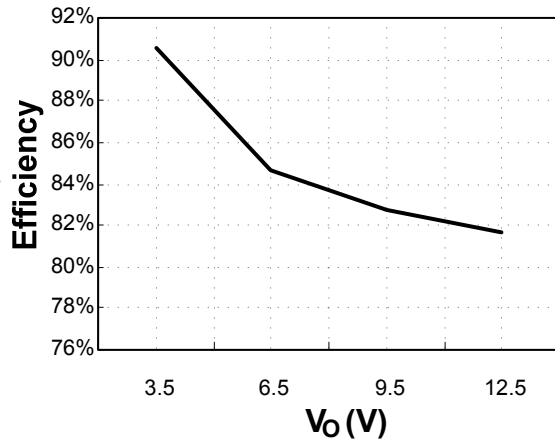

Efficiency vs. V_{IN}

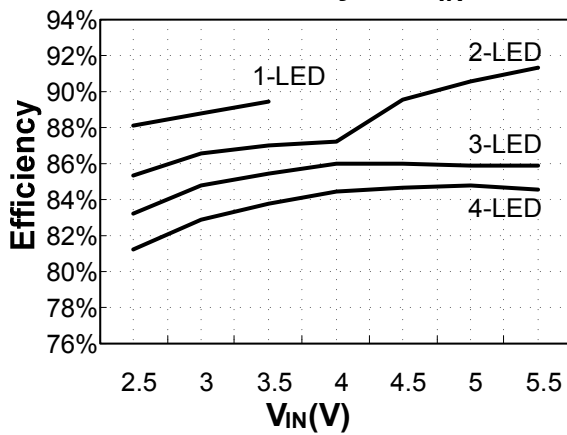

Efficiency vs. LED Current

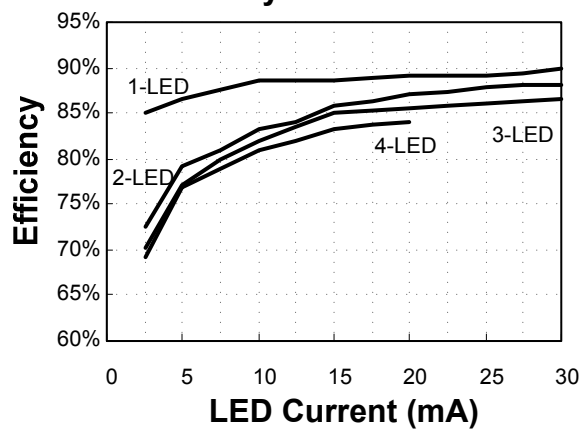

LED Current vs. V_{IN}

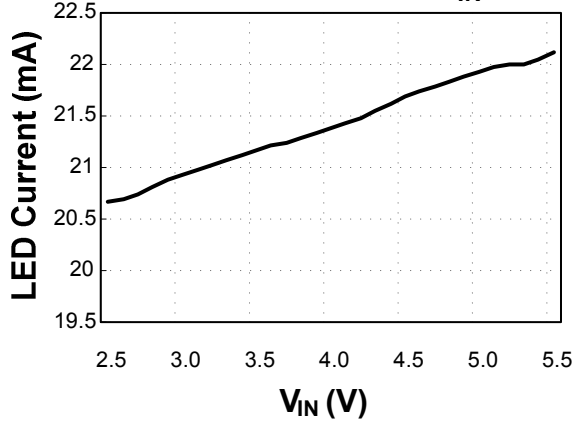

LED Current vs. V_o

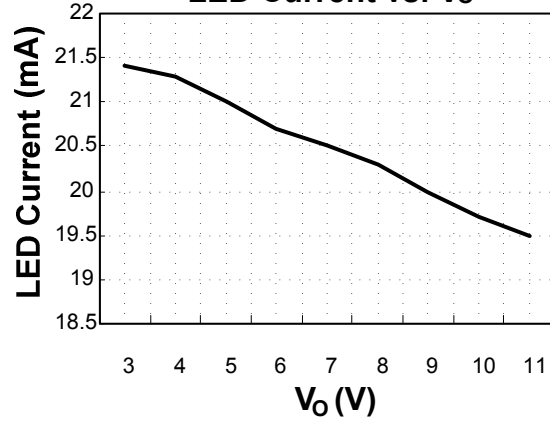



TYPICAL OPERATING CHARACTERISTICS

Frequency vs. Temperature

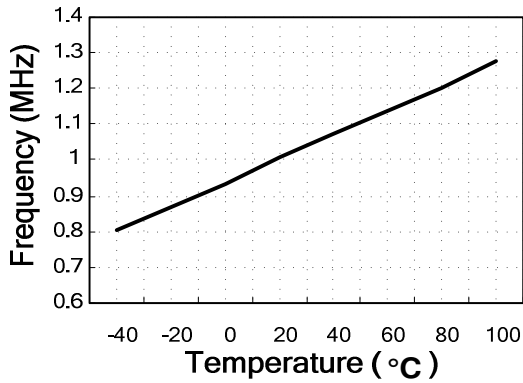

Dimming Control Typical Application

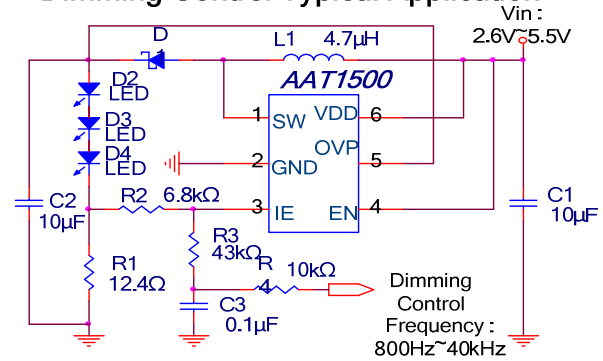

LED Current vs. Dimming Duty



Efficiency vs. Dimming Frequency

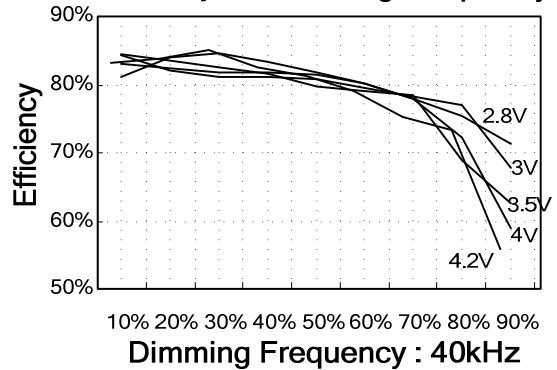

Efficiency vs. Dimming Frequency

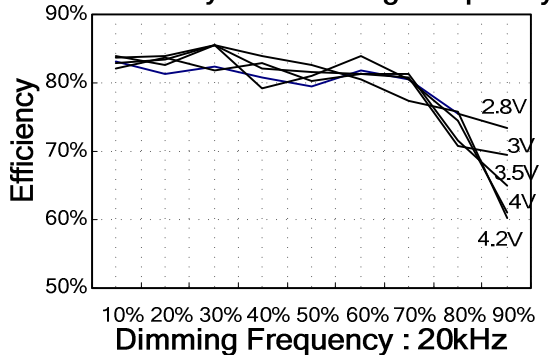

Efficiency vs. Dimming Frequency

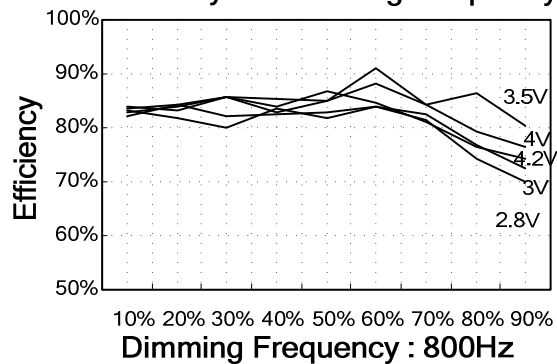



PIN DESCRIPTION

PIN NO SOT23-5	PIN NO SOT23-6	PIN NO TSOT23-6	PIN NO VSON8	NAME	I/O	DESCRIPTION
1	1	1	8	SW	O	Switch Pin
2	2	2	4	GND	-	Ground
3	3	3	6	IE	I	Inverting Input Pin of error amplifier
4	4	4	3	EN	I	Chip Enable/Disable(Active High)
-	5	5	1	OVP	I	Over Voltage Protection
5	6	6	2	V _{DD}	-	Supply Voltage
-	-	-	7	GND1	-	SW MOS Ground
-	-	-	5	NC	-	Not Connected

FUNCTION BLOCK DIAGRAM

SOT23-5

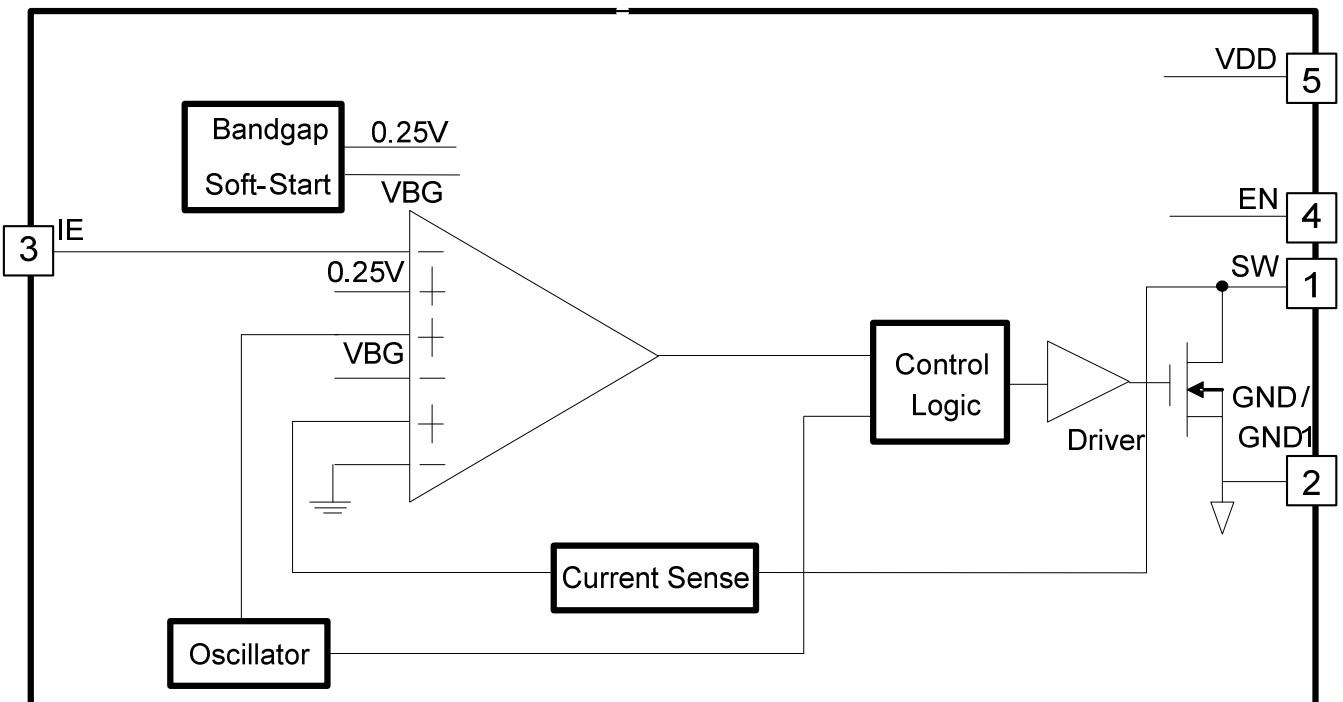



FUNCTION BLOCK DIAGRAM

SOT23-6 and TSOT23-6

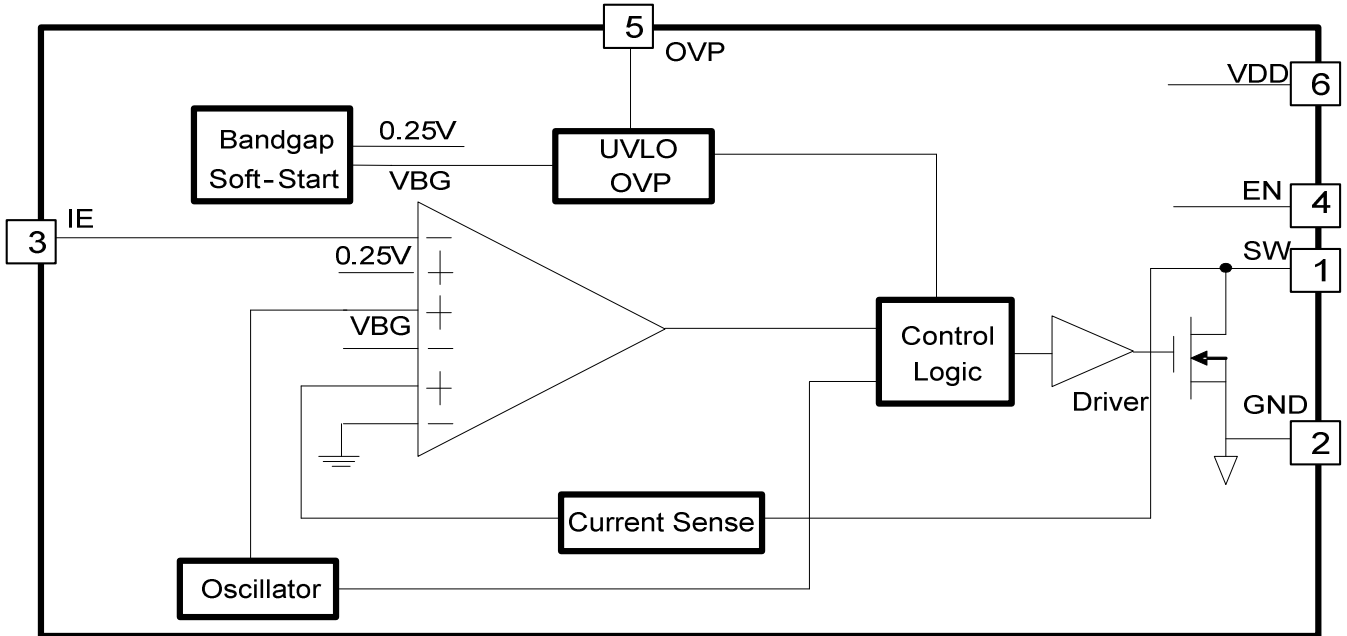

VSON8

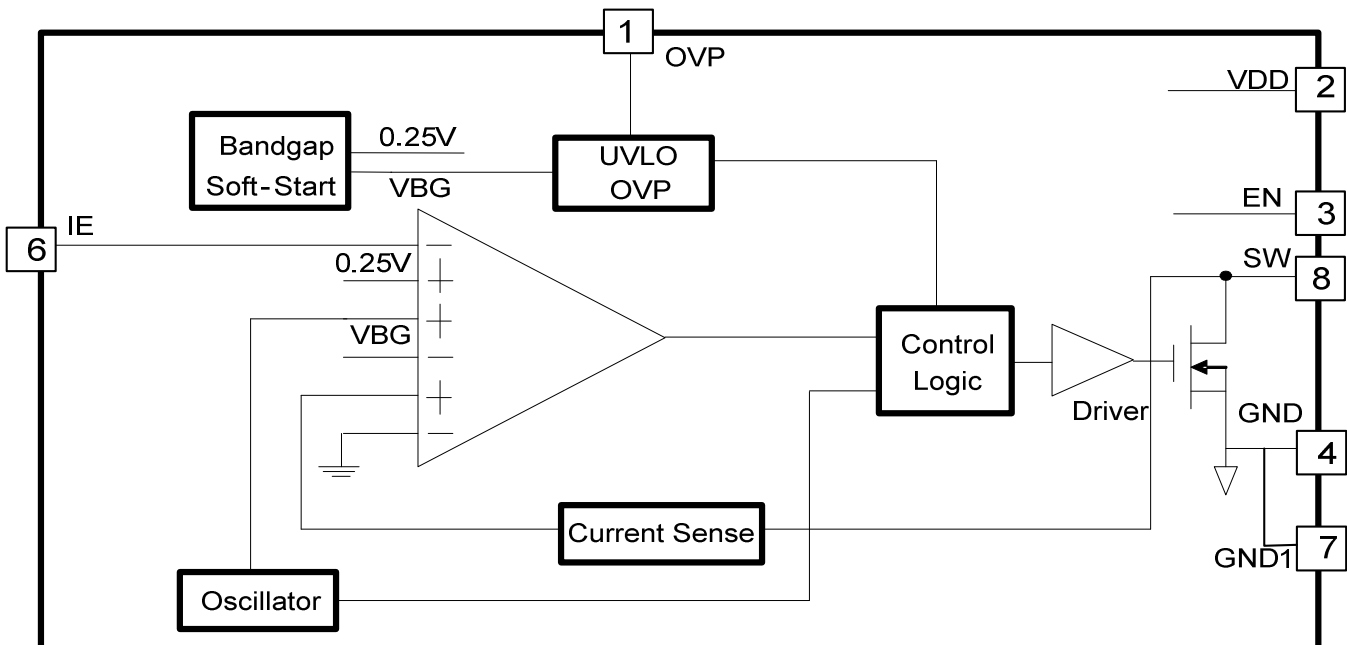



TYPICAL APPLICATION CIRCUIT

SOT23-5

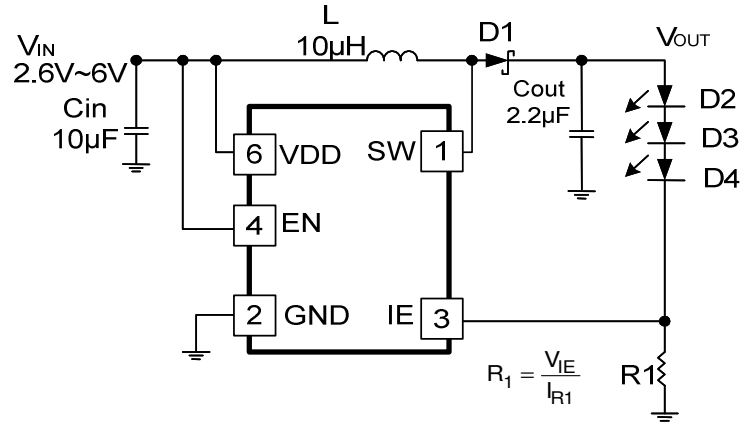

SOT23-6 and TSOT23-6

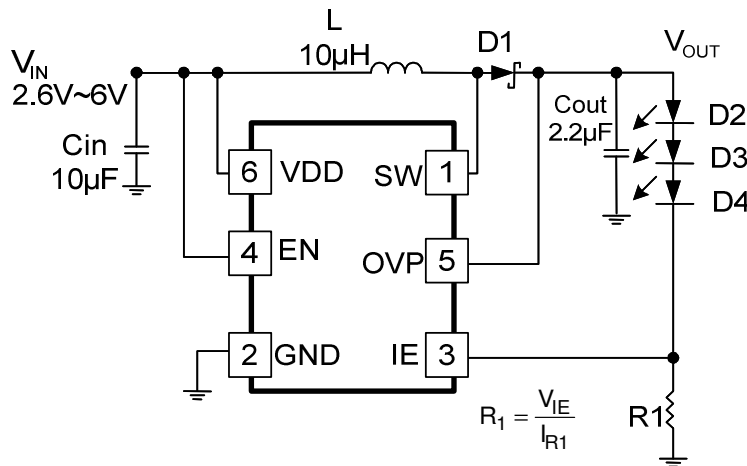

VSON8

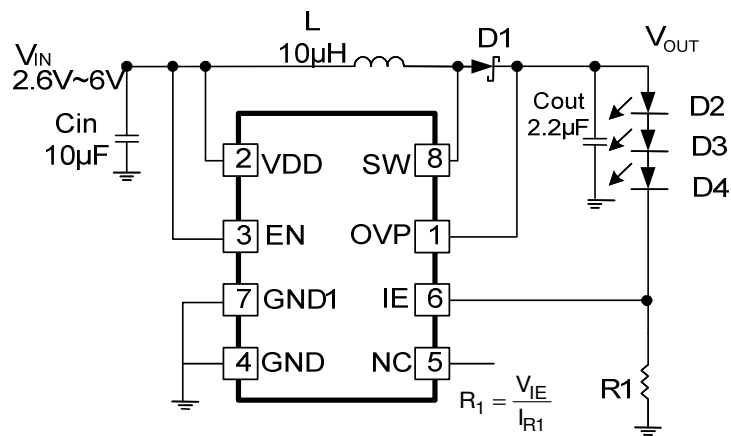



TYPICAL APPLICATION CIRCUIT

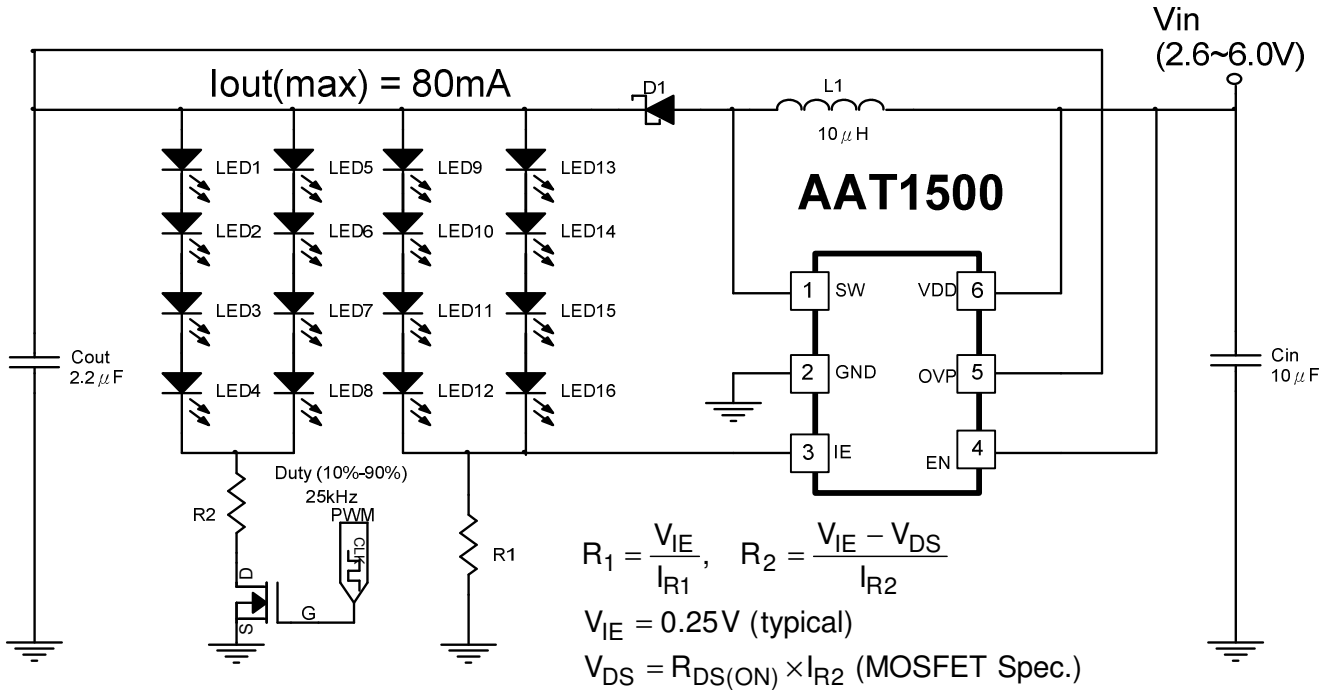



PACKAGE DIMENSION

SOT23-5(SOT25)

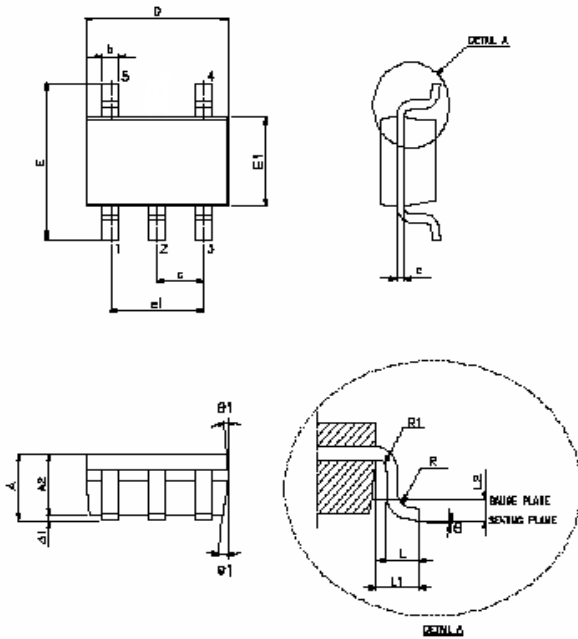

Symbol	Dimensions In Millimeters		
	MIN	TYP	MAX
A	1.05	1.20	1.35
A1	-----	-----	0.15
A2	1.0	1.1	1.2
b	0.3	-----	0.5
c	0.08	-----	0.2
D	2.90 BSC		
E	2.80 BSC		
E1	1.60 BSC		
e	0.95 BSC		
e1	1.90 BSC		
L	0.35	0.45	0.55
L1	0.60 REF		
L2	0.25 BSC		
R	0.1	-----	-----
R1	0.10	-----	0.25
θ	0°	5°	10°
θ1	3°	10°	7°



PACKAGE DIMENSION

SOT23-6(SOT26)

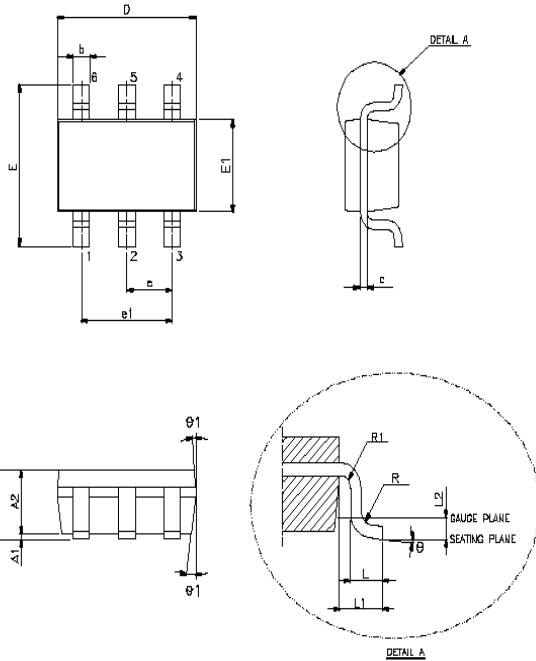

SYMBOL	Dimensions In Millimeters		
	MIN	TYP	MAX
A	1.05	1.2	1.35
A1	-----	-----	0.15
A2	1	1.1	1.2
b	0.4	-----	0.55
c	0.08	-----	0.2
D	2.90 BSC		
E	2.80 BSC		
E1	1.60 BSC		
e	0.95 BSC		
e1	1.90 BSC		
L	0.35	0.45	0.55
L1	0.60 REF		
L2	0.25 BSC		
R	0.10	-----	-----
R1	0.10	-----	0.25
θ	0°	5°	10°
θ1	3°	5°	7°



PACKAGE DIMENSION

TSOT23-6 (TSOT26)

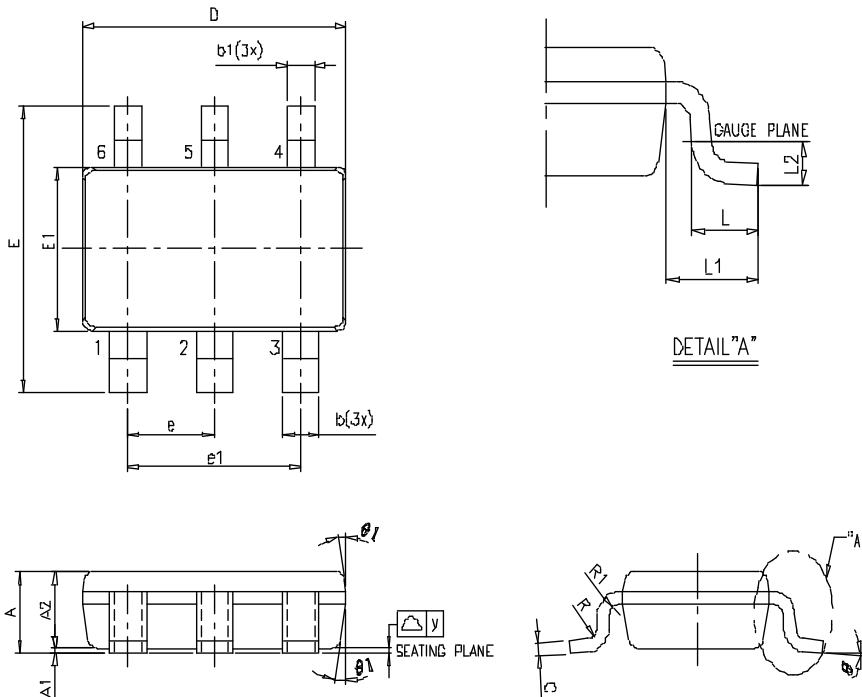

Symbol	Dimensions In Millimeters		
	MIN	TYP	MAX
A	0.75	-----	0.9
A1	0	-----	0.1
A2	0.7	0.75	0.8
b	0.4	-----	0.5
c	0.08	-----	0.2
D	2.8	2.9	3
E	2.6	2.8	3
E1	1.5	1.6	1.7
e	0.95 BSC		
e1	1.90 BSC		
L	0.3	0.45	0.6
L1	0.60 REF		
L2	0.25 BSC		
R	0.1	-----	-----
R1	0.1	-----	0.25
θ	0°	4°	8°
θ1	4°	10°	12°



PACKAGE DIMENSION

VSON8

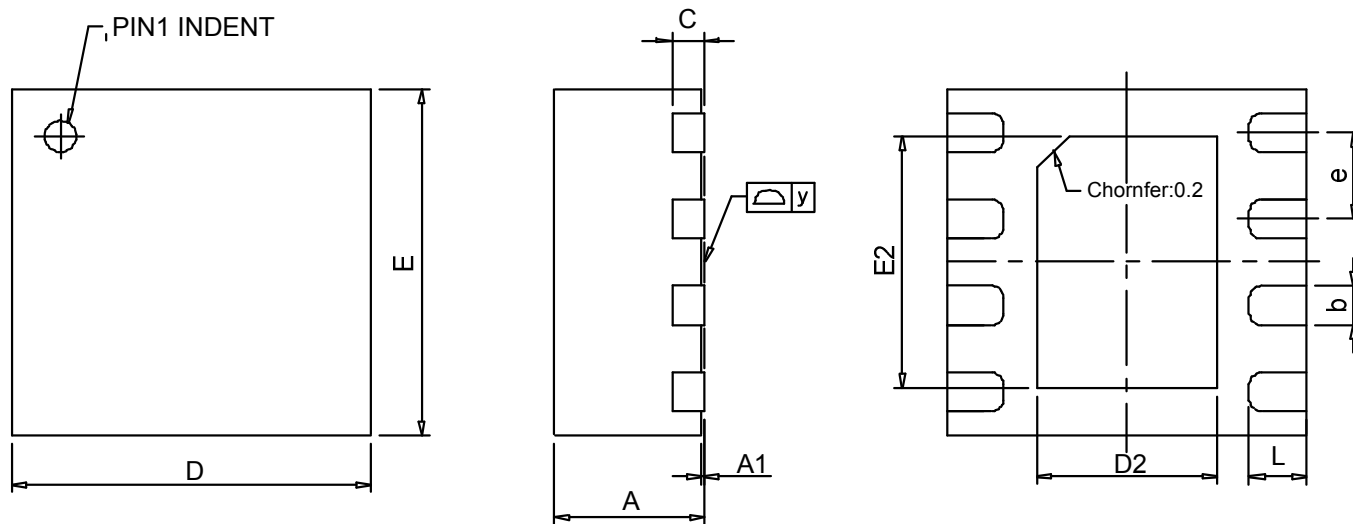

Symbol	Dimensions In Millimeters		
	MIN	TYP	MAX
A	0.8	0.9	1.0
A1	0.00	0.02	0.05
b	0.20	0.25	0.30
C	0.19	0.20	0.25
D	2.1	2.2	2.3
D2	1.0	1.1	1.2
E	2.1	2.2	2.3
E2	1.5	1.6	1.7
e	-----	0.55	-----
L	0.25	0.35	0.45
y	0.000	-----	0.076