

To all our customers

---

## **Regarding the change of names mentioned in the document, such as Mitsubishi Electric and Mitsubishi XX, to Renesas Technology Corp.**

---

The semiconductor operations of Hitachi and Mitsubishi Electric were transferred to Renesas Technology Corporation on April 1st 2003. These operations include microcomputer, logic, analog and discrete devices, and memory chips other than DRAMs (flash memory, SRAMs etc.) Accordingly, although Mitsubishi Electric, Mitsubishi Electric Corporation, Mitsubishi Semiconductors, and other Mitsubishi brand names are mentioned in the document, these names have in fact all been changed to Renesas Technology Corp. Thank you for your understanding. Except for our corporate trademark, logo and corporate statement, no changes whatsoever have been made to the contents of the document, and these changes do not constitute any alteration to the contents of the document itself.

Note : Mitsubishi Electric will continue the business operations of high frequency & optical devices and power devices.

Renesas Technology Corp.  
Customer Support Dept.  
April 1, 2003

# M63001FP

6CH ACTUATOR DRIVER

## < FEATURES >

M63001FP is 6ch actuator driver.

This circuit includes 6ch-BTL driver and Thermal Shut Down circuit and Stand-by circuit and Mute circuit (only 6ch) that is able to drive six actuators and motor with one IC.

## < APPLICATION >

CD-player, MD,CD-ROM, CD-R etc.

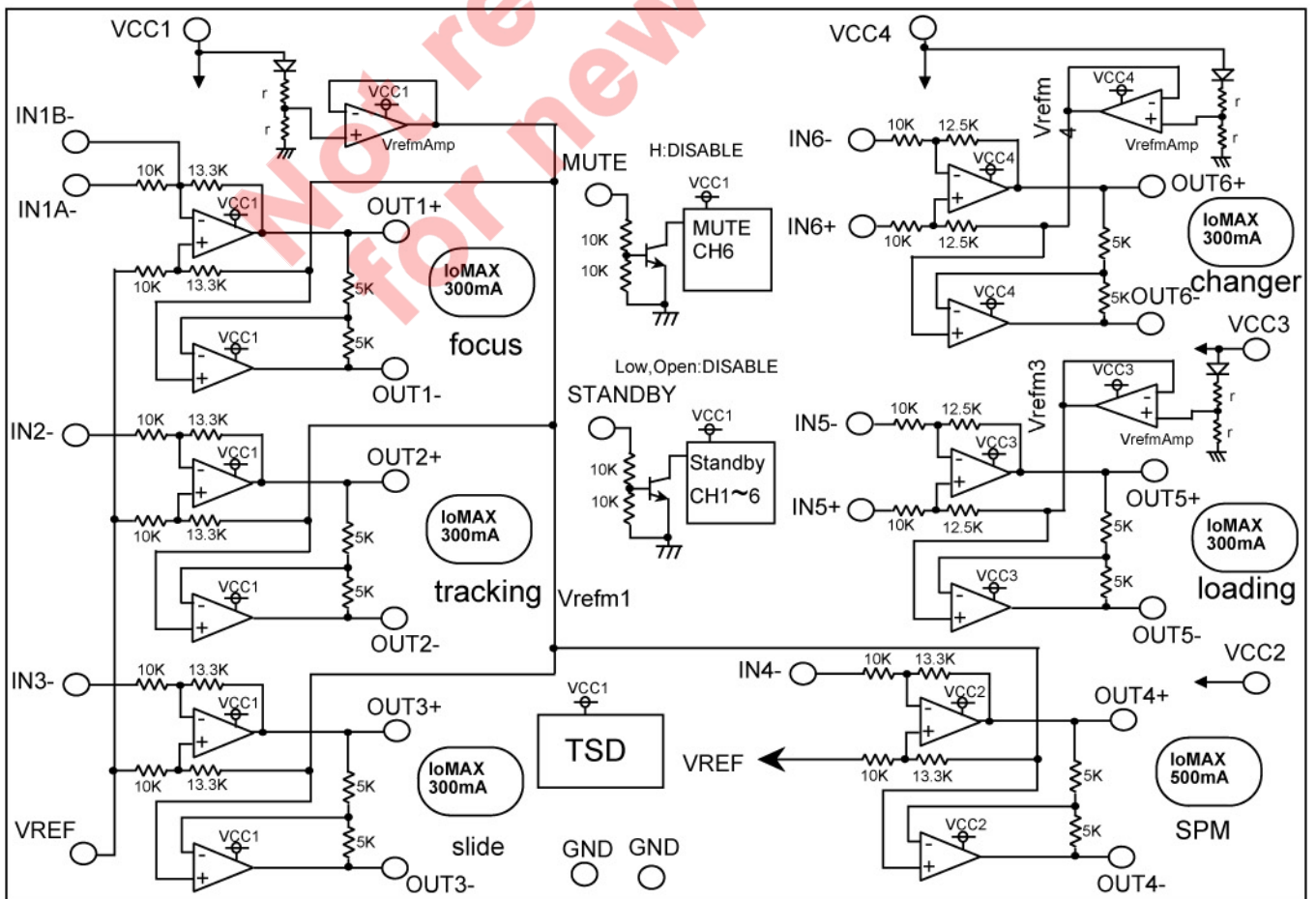
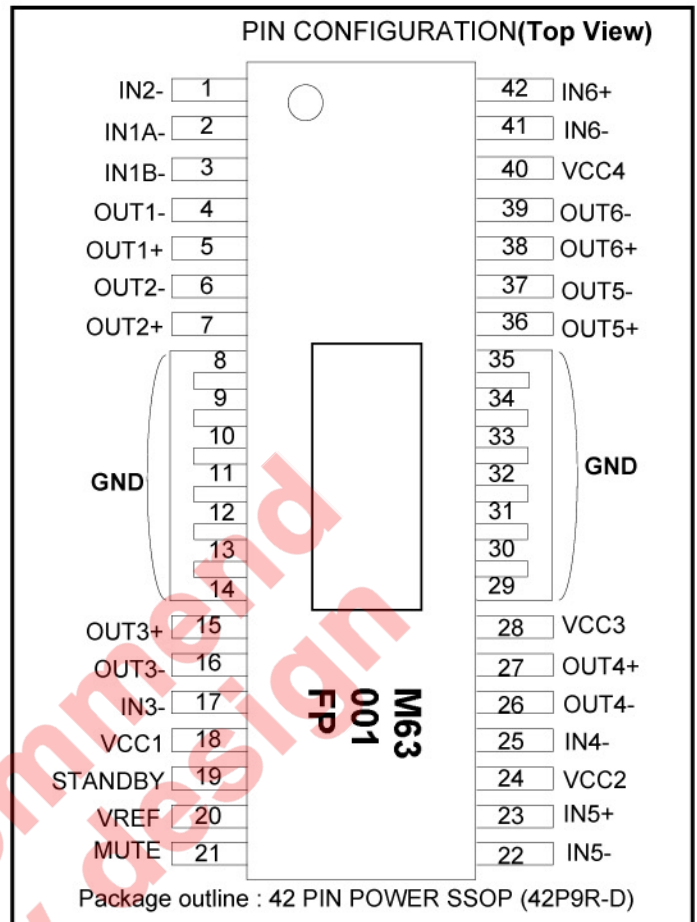

<PIN FUNCTION>

TERMINAL	SYMBOL	TERMINAL FUNCTION	TERMINAL	SYMBOL	TERMINAL FUNCTION
1	IN2-	CH2 inverted input	42	IN6+	CH6 non-inverted input
2	IN1A-	CH1 inverted input	41	IN6-	CH6 inverted input
3	IN1B-	CH1 output offset control	40	VCC4	Power supply4(CH6)
4	OUT1-	CH1 inverted output	39	OUT6-	CH6 inverted output
5	OUT1+	CH1 non-inverted output	38	OUT6+	CH6 non-inverted output
6	OUT2-	CH2 inverted output	37	OUT5-	CH5 inverted output
7	OUT2+	CH2 non-inverted output	36	OUT5+	CH5 non-inverted output
8~14	GND	GND	29~35	GND	GND
15	OUT3+	CH2 non-inverted output	28	VCC3	Power supply3(CH5)
16	OUT3-	CH3 inverted output	27	OUT4+	CH4 non-inverted output
17	IN3-	CH3 inverted input	26	OUT4-	CH4 inverted output
18	VCC1	Power supply 1(CH1,CH2,CH3)	25	IN4-	CH4 inverted input
19	STANDBY	STANDBY signal input	24	VCC2	Power supply2(CH4)
20	VRFE	CH1~CH4 Reference voltage input	23	IN5+	CH5 non-inverted output
21	MUTE	Mute signal input (CH6)	22	IN5-	CH5 inverted input

<ABSOLUTE MAXIMUM RATING> (Ta=25°C)

SYMBOL	PARAMETER	CONDITIONS	RATING	Units
VCC1,VCC2 VCC3,VCC4	Power supply		15	V
Io1	Output current 1		0.3	A
Io2	Output current 2	CH4 output current	0.5	A
Vin1	Maximum input voltage of terminals 1	1,2,3,17,19,20,21pin	0~VCC1	V
Vin2	Maximum input voltage of terminals2	25pin	0~VCC2	V
Vin3	Maximum input voltage of terminals3	22,23pin	0~VCC3	V
Vin4	Maximum input voltage of terminals4	41,42pin	0~VCC4	V
Pt	Power dissipation	Free Air	1.2	W
Kθ	Thermal delating	Free Air	9.6	mW/°C
Tj	Thermal delating		150	°C
Topr	Operating temperature		-20 ~ +75	°C
Tstg	Storage temperature		-40 ~ +125	°C

<RECOMMENDED OPERATING CONDITIONS>

SYMBOL	PARAMETER	LIMITS			Units
		MIN	TYP	MAX	
VCC1,VCC2 VCC3,VCC4	Power supply	4.5	5.0	13.2	V
Io1	CH1,2,3,5,6 Output drive current	—	—	300	mA
Io2	CH4 Output drive current	—	—	500	mA

<ELECTRICAL CHARACTERISTICS>

(Ta=25°C, VCC1=VCC2=VCC3=VCC4=5V unless otherwise noted.)

SYMBOL	PARAMETER	CONDITIONS	LIMITS			Units
			MIN	TYP	MAX	
IccS	STANDBY circuit current	VCC1 and VCC2 and VCC3 and VCC4 total input current (STANDBY= Low or OPEN)	—	—	10	uA
Icc	Sleep Mode supply current	VCC1 and VCC2 and VCC3 and VCC4 total input current (VREF=IN(+)=IN(-)=2.5V,IN1B(-)=Open,Standby= Hi)	—	24	34	mA
Vsat1	Output Saturation voltage1	Top and Bottom saturation voltage. (CH1,CH2,CH3,CH5,CH6) Load current 0.3A(bootstrap)	—	1.5	2.1	V
Vsat2	Output Saturation voltage2	Top and Bottom saturation voltage.(CH4) Load current 0.5A(bootstrap)	—	1.5	2.1	V
Gain1	Gain between input and output 1	CH1,CH2,CH3,CH4 Gain between input and output Gain1= $\frac{OUT(-)-OUT(+)}{IN(-)-VREF}$	7.60	8.52	9.35	dB
Gain2	Gain between input and output 2	CH5,CH6 Gain between input and output Gain2= $\frac{OUT(-)-OUT(+)}{IN(-)-IN(+)}$	7.04	7.96	8.79	dB
Vofs1	Output offset voltage 1	Output offset voltage(CH1,CH2,CH3,CH4) IN(+)=VREF(2.5V)	-35	—	+35	mV
Vofs2	Output offset voltage 2	Output offset voltage(CH5,CH6) IN(+)=IN(-)=(2.5V)	-35	0	+35	mV
Vin1	Input voltage range1	Input voltage range <CH1(IN1A-) and CH2,CH3(IN-)>	0	—	VCC1	V
Vin2	Input voltage range2	Input voltage range <CH4(IN-)>	0	—	VCC2	V
Vin3	Input voltage range3	Input voltage range <IN5-,IN5+>	0	—	VCC3	V
Vin4	Input voltage range4	Input voltage range <IN6-,IN6+>	0	—	VCC4	V
VinR	VREF input voltage range	VCC1=VCC2	0	—	VCC1	V
VsH	STANDBY H voltage	Minimum H voltage ofSTANDBY	2.0	—	—	V
VsL	STANDBY L voltage	Maximum L voltage of STANDBY	—	—	0.8	V
IsH	STANDBY input current H	STANDBY input current (STANDBY=5V)	—	—	520	uA
VmH	MUTE H voltage	Minimum H voltage ofMUTE	2.0	—	—	V
VmL	MUTE L voltage	Maximum L voltage of MUTE	—	—	0.8	V
ImH	MUTE input current H	MUTE input current (MUTE=5V)	—	—	520	uA

<I/O CHARACTERISTICS>

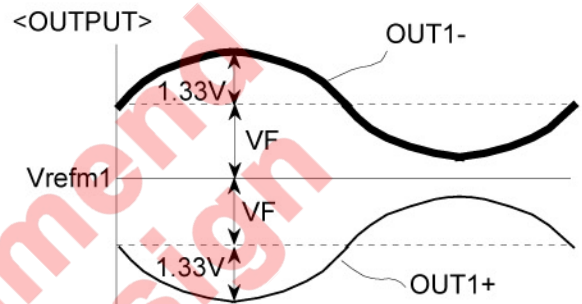
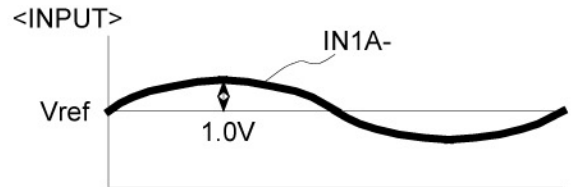
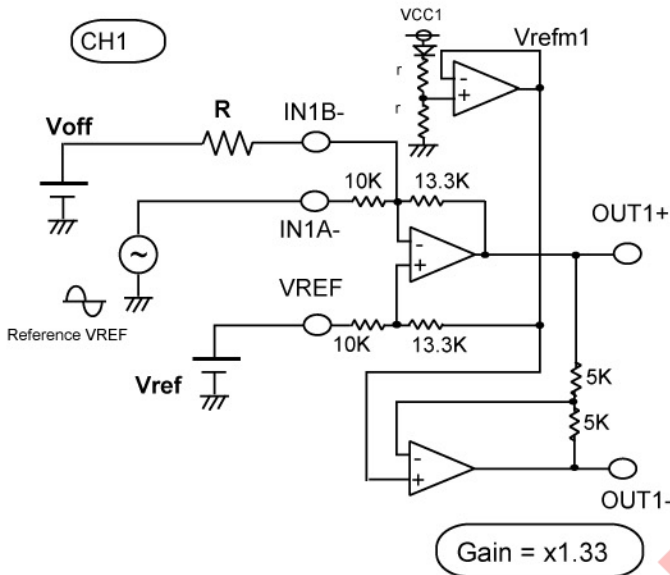

$$VF = [(Vrefm1 - Vref) \times 10k / 23.3k + Vref - Voff] \times 13.3k / R$$

$$Vrefm1 = (VCC1 - 0.7) / 2$$

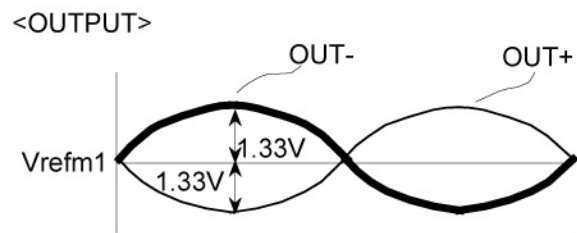
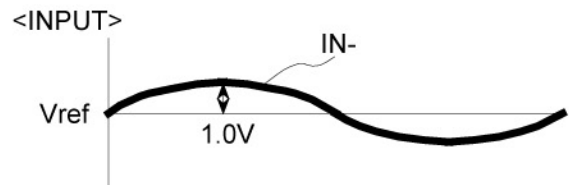
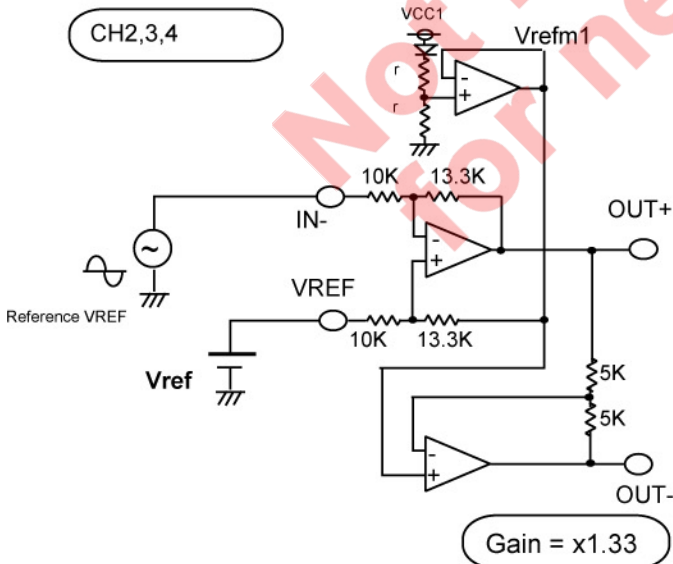

$$Vrefm1 = (VCC1 - 0.7) / 2$$

note) It is possible to give different supply voltage for VCC1, VCC2.  
but Output middle voltage of CH1~CH4 are determined by VCC1 voltage only.

<I/O CHARACTERISTICS>

CH5

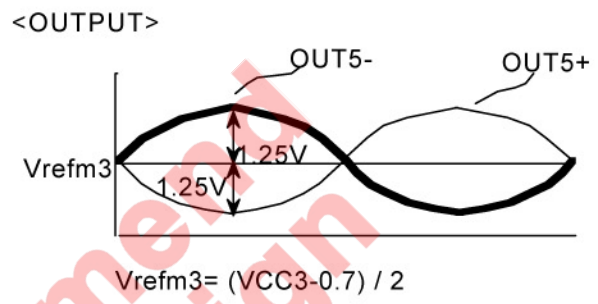
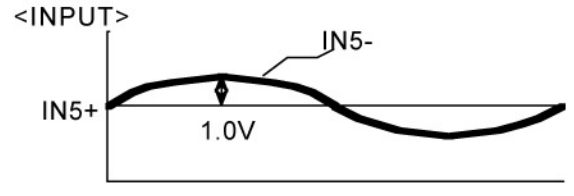
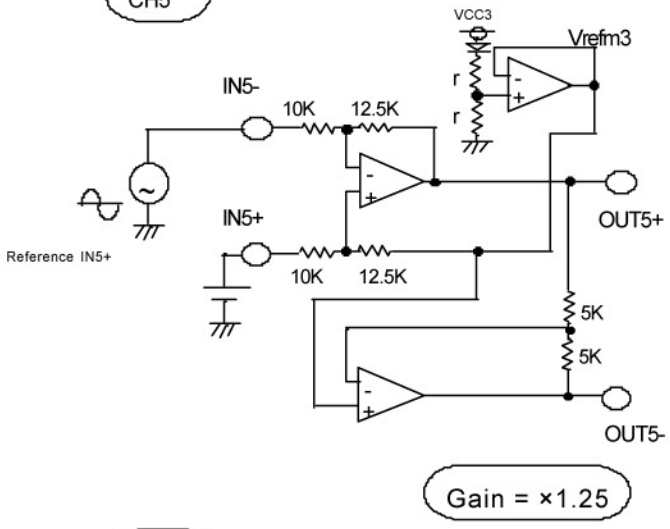

CH6

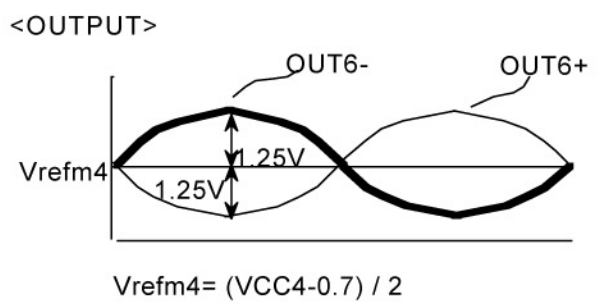
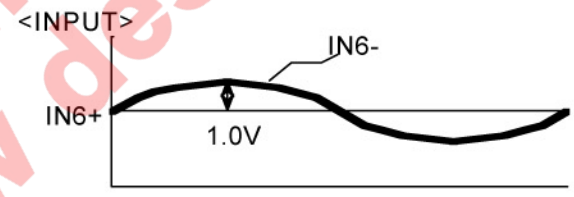
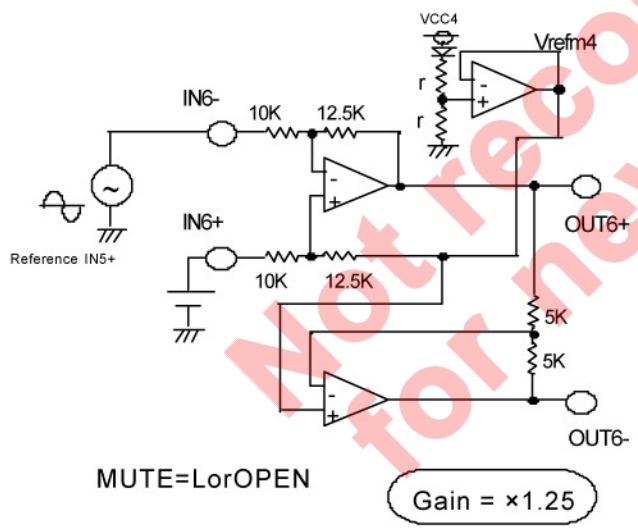

Between output voltage (DC input)

IN+	IN-	CH5	CH6	
			MUTE=L OPEN	MUTE=H
0V	0V	BRAKE	BRAKE	DISABLE
0V	4V	Reverse 10V	Reverse10V	DISABLE
4V	0V	Forward 10V	Forward10V	DISABLE
4V	4V	BRAKE	BRAKE	DISABLE

- Supply voltage of VCC3 and VCC4 give different voltage of VCC1 and VCC2.
- CH6 include Mute circuit.

**M63001FP**

6CH ACTUATOR DRIVER

<THERMAL DERATING>

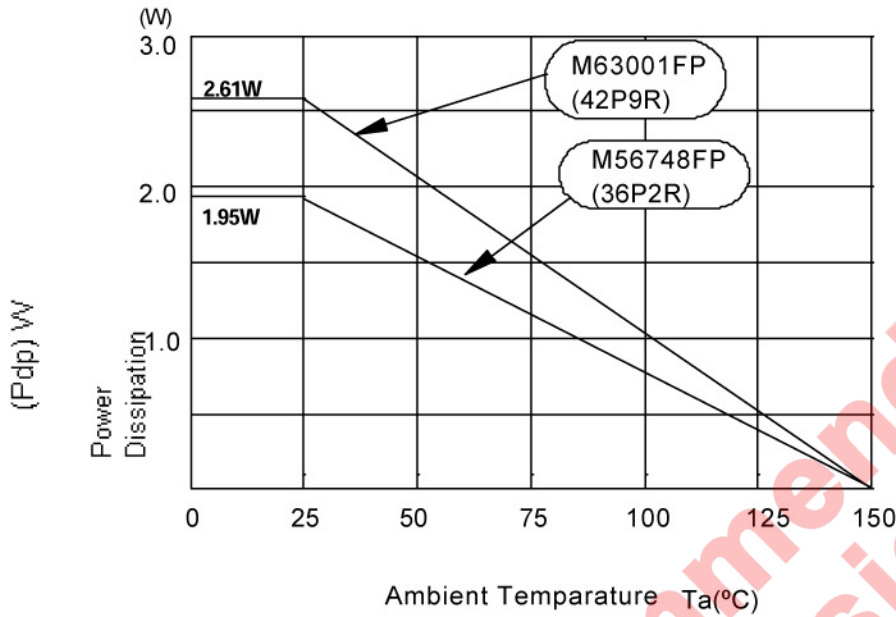

Characteristics of Left graph is using both sides board and measuring.  
\*Board size: 9.6×11.7mm(t=1.5mm)

<VREF input current>

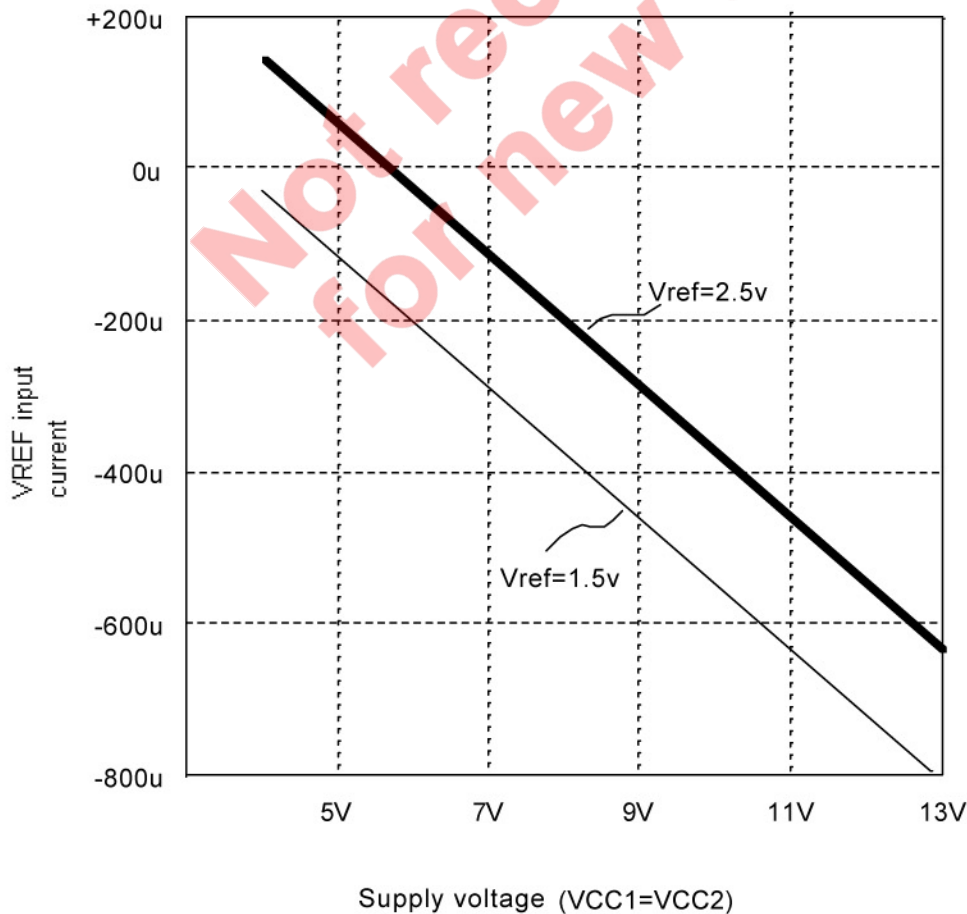





<APPLICATION CIRCUIT> Active loading motor and changer motor (CH5,CH6)

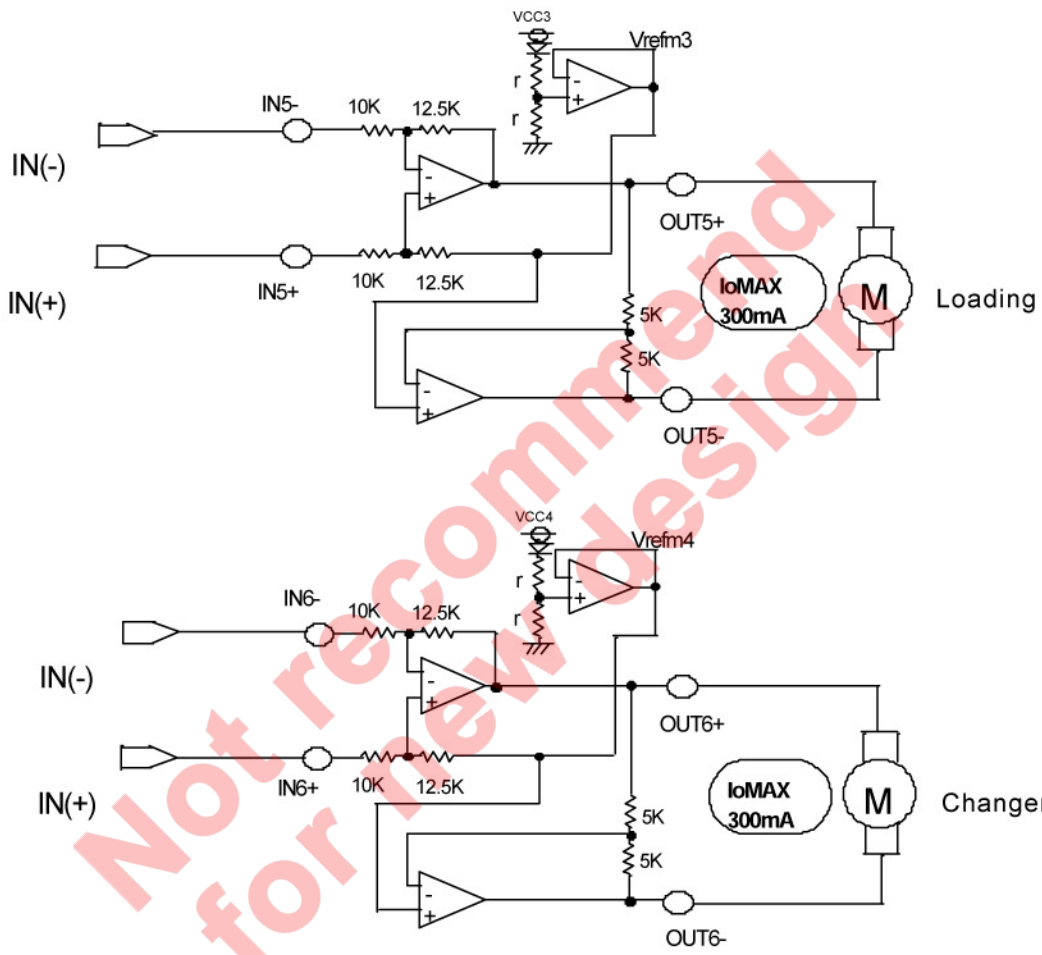

<APPLICATION CIRCUIT> Active loading motor and sorenoid (CH5,CH6)

