



### FEATURES

- Default +5V Output Voltage.
- Adjustable Output Voltage with Two Resistors.
- Power-Saving Shutdown Mode (7 $\mu$ A typical).
- 120KHz Switching Rate.
- On-Chip Low Battery Detector.

### APPLICATIONS

- Palmtop & Notebook Computers.
- Battery Charger Supply.
- Cellular Telephone.
- LCD Contrast Supply.
- Flash Memory Programmer.
- Battery Backup Supplies.
- Portable Instruments.

### DESCRIPTION

The AIC1630A is a DC-DC converter designed to drive an external power switch for more flexibility, especially in higher voltage and larger power applications. Typically six components are required to set up a step up configuration easily achieving efficiency beyond 80%. A few more components are required to set up a step down configuration delivering 4A load current with 83% typical efficiency, 86% at 2A load, and 300 $\mu$ A quiescent current.

The output voltage can be internally set to 5V or externally set to an arbitrary value below breakdown voltage of the power switch. Logic-controlled shutdown mode is provided for power saving. The low battery detector can be also configured as a linear regulator.

120KHz switching rate reduces the inductor size. Inductors of 25 $\mu$ H to 50 $\mu$ H inductance are recommended for most applications.

### TYPICAL APPLICATION CIRCUIT

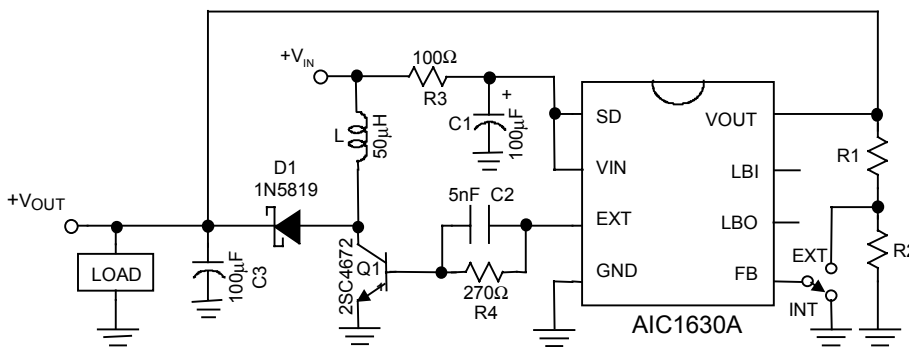

Note :  $V_{IN} \geq 1.8V$  ,  $V_{OUT} \leq 7V$

**High Efficiency Step-Up DC/DC Converter**

### ORDERING INFORMATION

AIC1630A XX

- PACKAGE TYPE  
N: PLASTIC DIP  
S: SMALL OUTLINE
- TEMPERATURE RANGE  
C=0°C~70°C

ORDER NUMBER	PIN CONFIGURATION
AIC1630ACN (PLASTIC DIP)	TOP VIEW 
AIC1630ACS (PLASTIC SO)	

**ABSOLUTE MAXIMUM RATINGS**

Supply Voltage .....	<b>7.0V</b>
DC Voltage Applied On All Other Pins .....	<b>7.0V</b>
Operating Temperature Range .....	<b>0°C~70°C</b>
Storage Temperature Range .....	<b>-65°C ~150°C</b>

**TEST CIRCUIT**

Refer to Typical Application Circuit.

**ELECTRICAL CHARACTERISTICS** ( $V_{IN}=3.0V$ ,  $T_a=25^{\circ}C$ , unless otherwise specified.)

PARAMETER	TEST CONDITIONS	MIN.	TYP.	MAX.	UNIT
Input Voltage		1.8		7	V
Default Output Voltage	$I_L=200mA$	4.8	5	5.2	V
Switch Off Current			105	140	$\mu A$
Shutdown Mode Current			7	15	$\mu A$
Recovery Time from Shutdown	$V_{IN}=2.5V$ , $I_L=200mA$		0.4		mS
Efficiency	$I_L=300mA$ Fig. 1 in Appl. Examples		85		%
Line Regulation	$V_{IN}=2.2\sim 3.3V$ $V_{OUT}=5V$ , $I_L=100mA$		0.6		% $V_{OUT}$
Load Regulation	$I_L=10mA\sim 500mA$ $V_{OUT}=5V$		2.5		% $V_{OUT}$
Oscillator Frequency		90	120	150	KHz
LBI Pin Trip Point		1.17	1.22	1.27	V
FB Threshold Voltage		0.598	0.617	0.636	V
EXT Pin Driving Capability	Pin 8=5V, Pin 3= 0.85V Sourcing Sinking		80 50		mA mA
LBO "ON Resistance"	$V_{IN}=2V$		45		$\Omega$
Input Pin Bias Current				10	nA/Pin
Output Pin Leakage				10	nA/Pin



### TYPICAL PERFORMANCE CHARACTERISTICS

Ext Pin Sourcing Capability

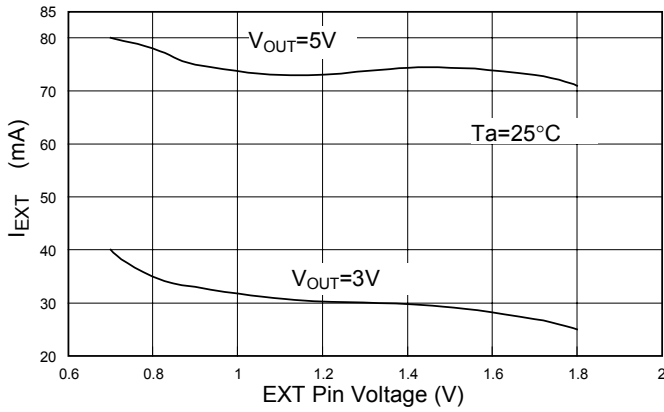

Ext Pin Sourcing Capability vs Temperature

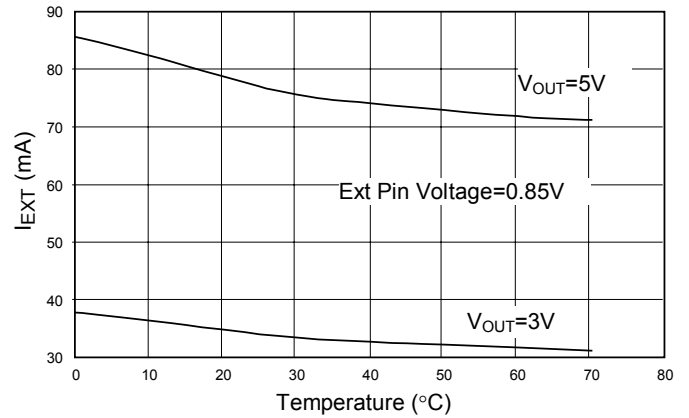

Ext Pin Sinking Capability

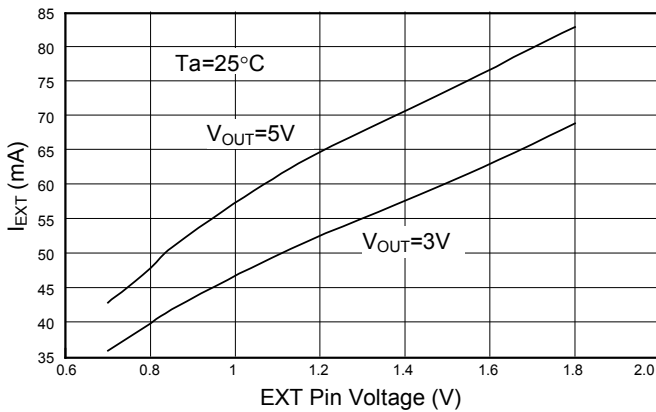

Ext Pin Sinking Capability vs Temperature

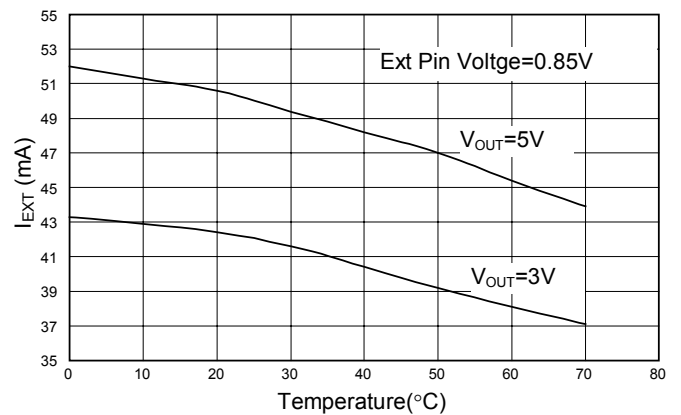

Switch off Supply Current vs Input Voltage

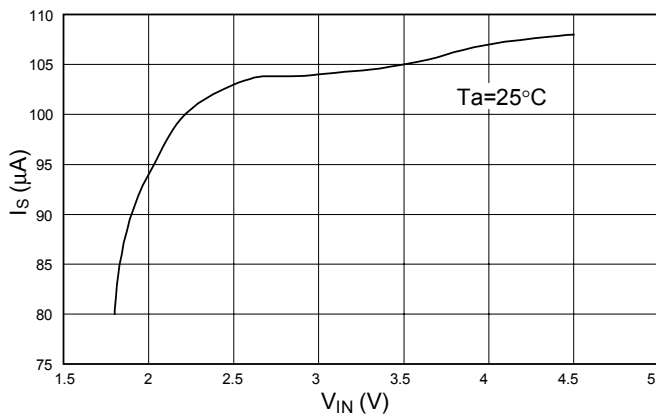

Switch Off Supply Current vs Temperature

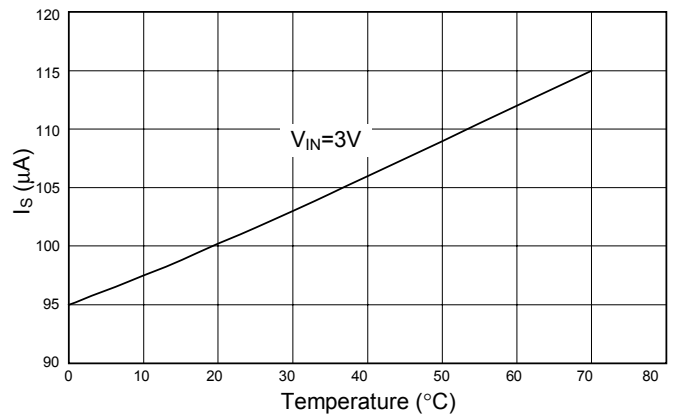



### TYPICAL PERFORMANCE CHARACTERISTICS (CONTINUED)

Shutdown Mode Supply Current vs Input Voltage

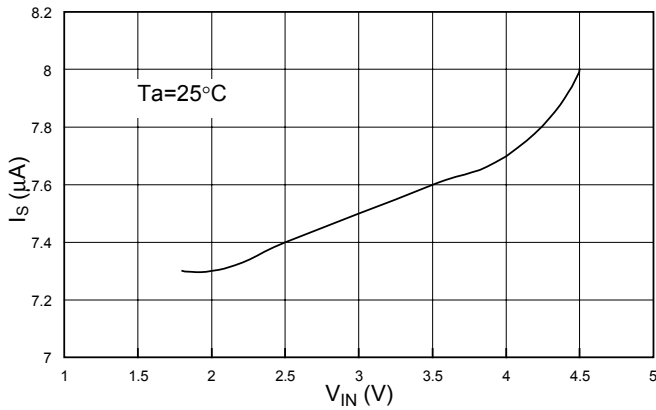

Shutdown Mode Supply Current vs Temperature

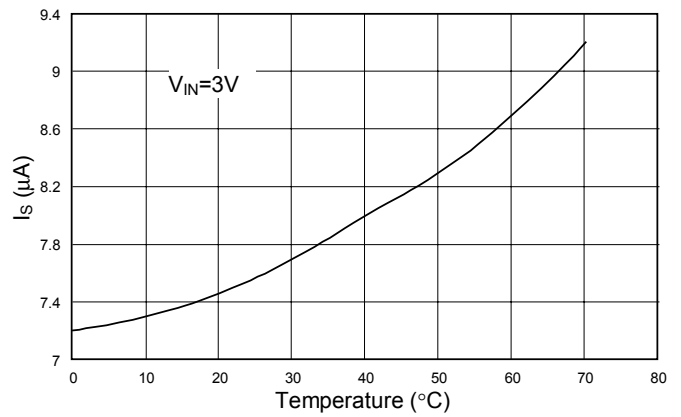

Oscillator Frequency vs Input Voltage

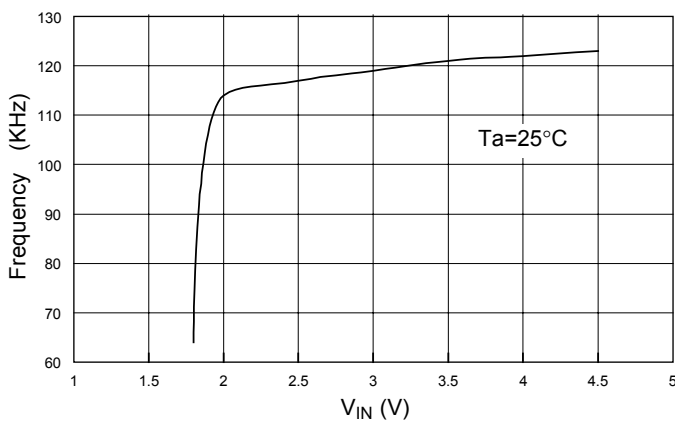

Oscillator Frequency vs Temperature

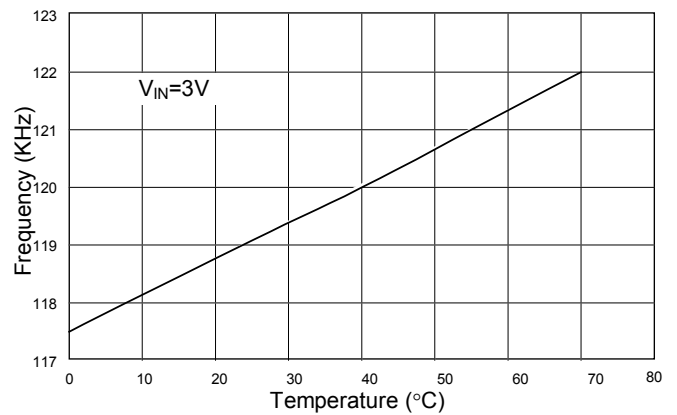

### BLOCK DIAGRAM

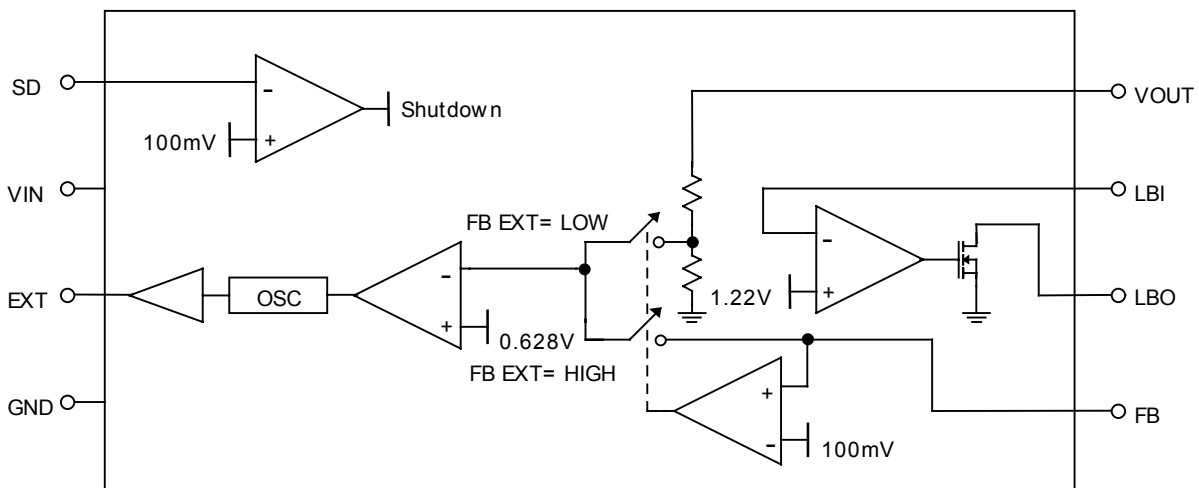



### PIN DESCRIPTION

**PIN 1: SD** - The AIC1630A goes in shutdown mode and consumes less than 10µA when SD pin is pulled to ground and it goes in normal operating mode when the SD pin is pulled to a positive voltage above 100mV.

**PIN 2: VIN** - Input supply.

**PIN 3: EXT** - Push-pull drive output to drive external power switch.

**PIN 4: GND** - Ground.

**PIN 5: FB** - Output voltage can either be internally set to 5 volt by grounding FB pin, or be externally set to an arbitrary voltage by applying to FB pin the divider voltage of two divider resistors.

V<sub>OUT</sub> voltage is given by the following equation:

$$\frac{R1}{R2} = \frac{V_{OUT}}{0.628} - 1$$

where R1=Resistor connected between FB pin and VOUT pin.

R2= Resistor connected between FB pin and ground.

V<sub>OUT</sub>=Output voltage to be set.

**PIN 6: LBO** - Open drain output of the battery low detector, with 45Ω “ON resistance” at V<sub>IN</sub>=2V. It is pulled low when the voltage on LBI pin is below 1.22V.

**PIN 7: LBI** - The noninverting input of the battery low detector, of which the inverting input is internally connects to 1.22V voltage reference.

**PIN 8: VOUT**- The output voltage feedbacks to the IC through this pin. If output voltage was externally set, the VOUT pin can be tied to any low impedance node with voltage between the external power switch threshold and 7V

### APPLICATION EXAMPLES

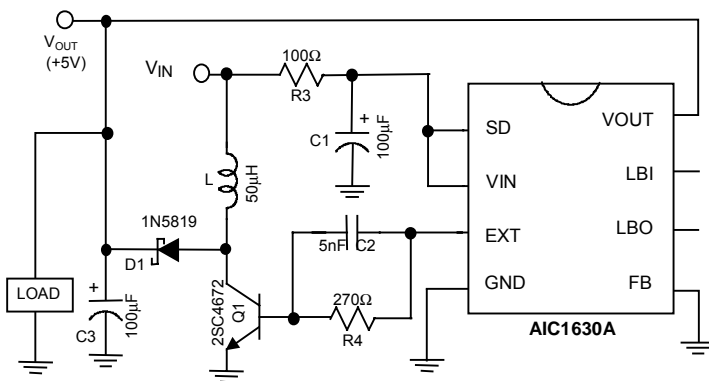
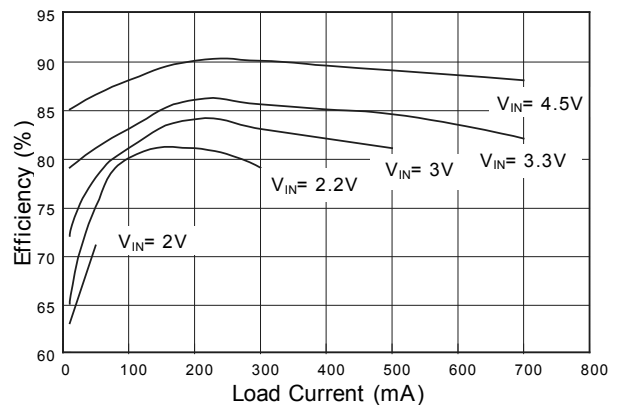
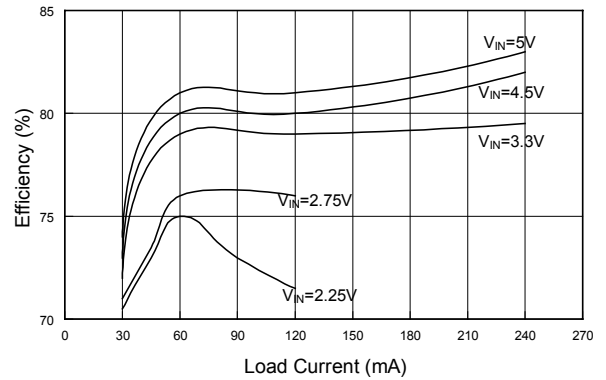
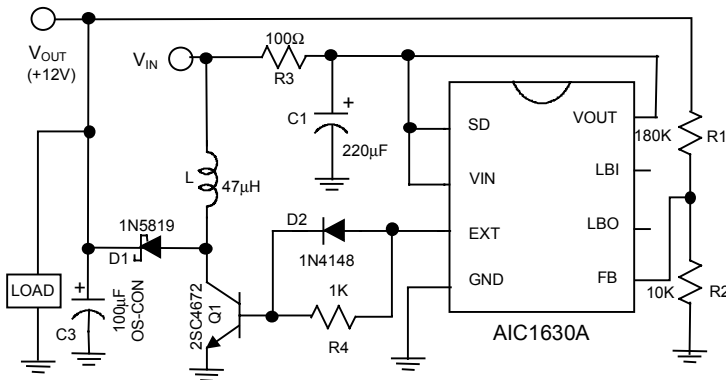

Fig. 1 5V Output Step-Up Converter





APPLICATION EXAMPLES (CONTINUED)



Note :  $V_{IN} \geq 2.2V$

Fig. 2 12V Output Step-Up Converter for Flash Memory

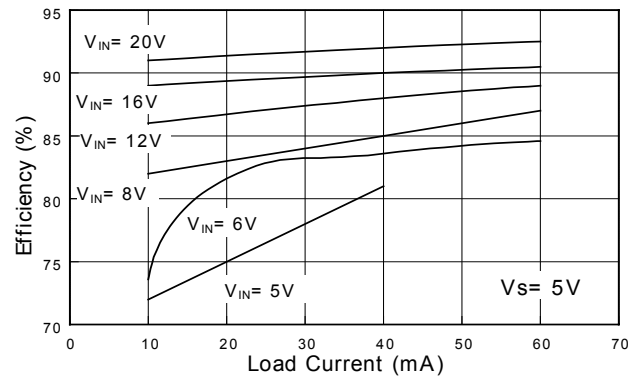
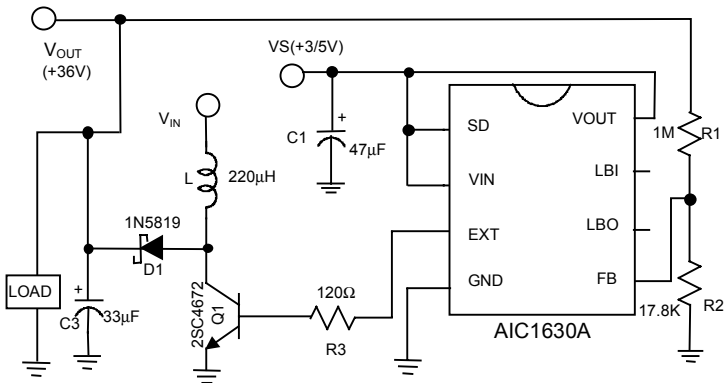

Fig. 3 36V Output Step-Up Converter for Color LCD

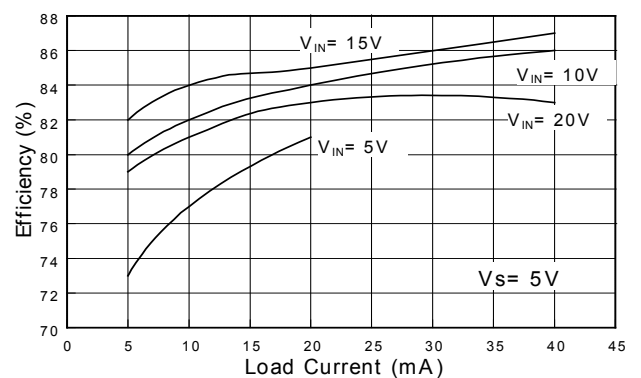
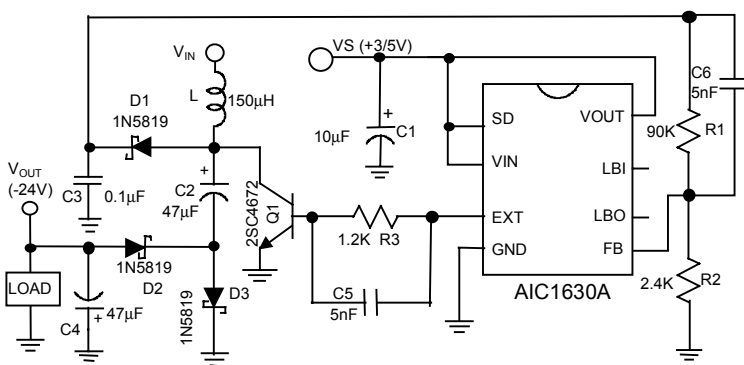
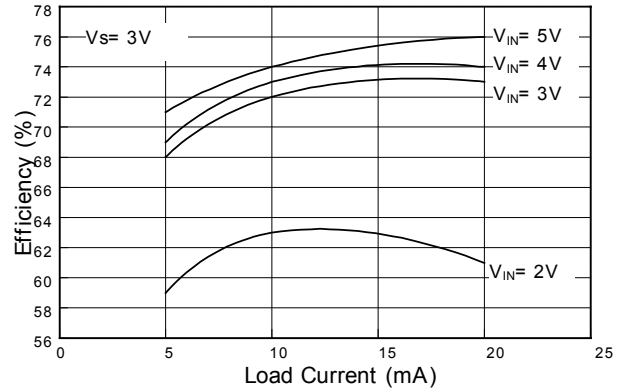
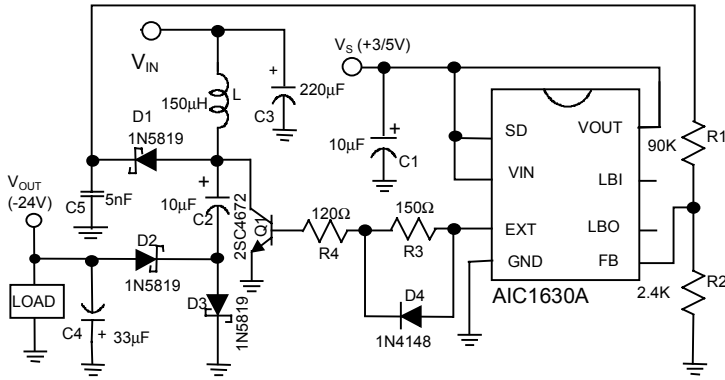

Fig. 4 -24V Output Inverting Converter for LCD



### APPLICATION EXAMPLES (CONTINUED)



**Fig. 5 2V Input 20mA Load -24V Output Inverting Converter for LCD**

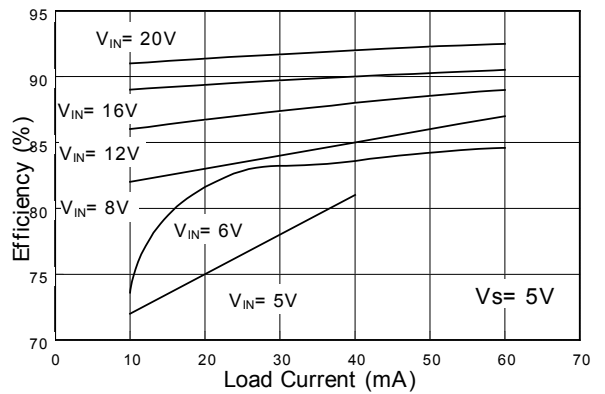
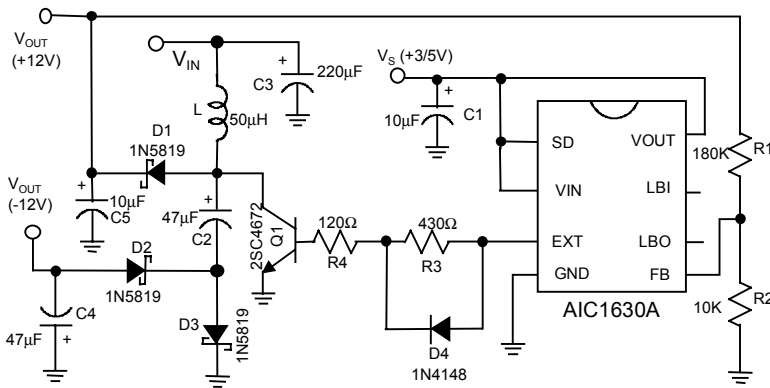

**Fig. 6 12V Dual Output Converter for computer for computer Interfacing**

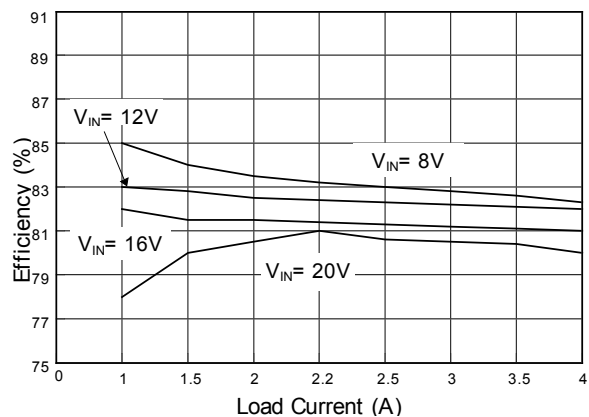
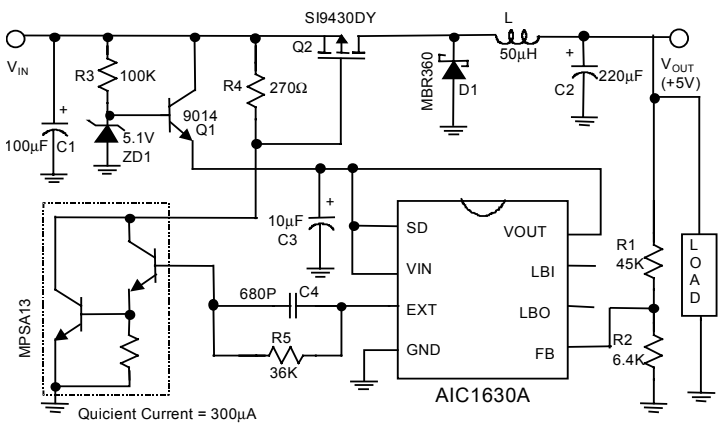

**Fig. 7 5V Output Step-Down Converter -1**



APPLICATION EXAMPLES (CONTINUED)

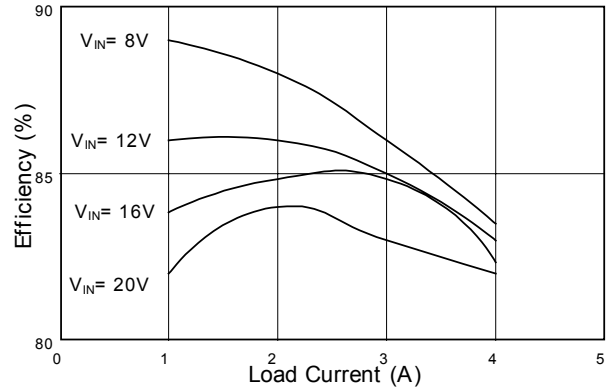
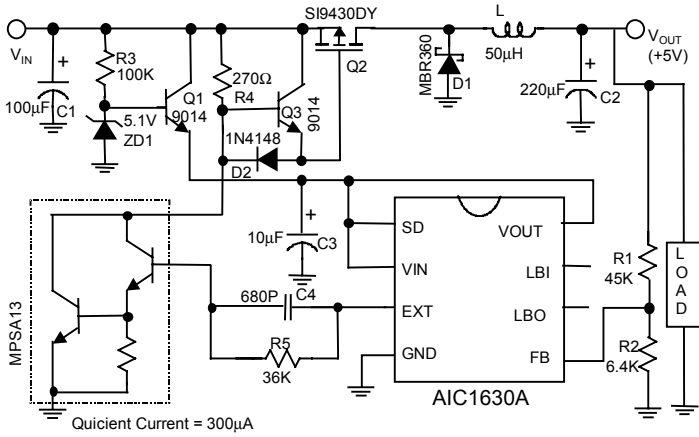
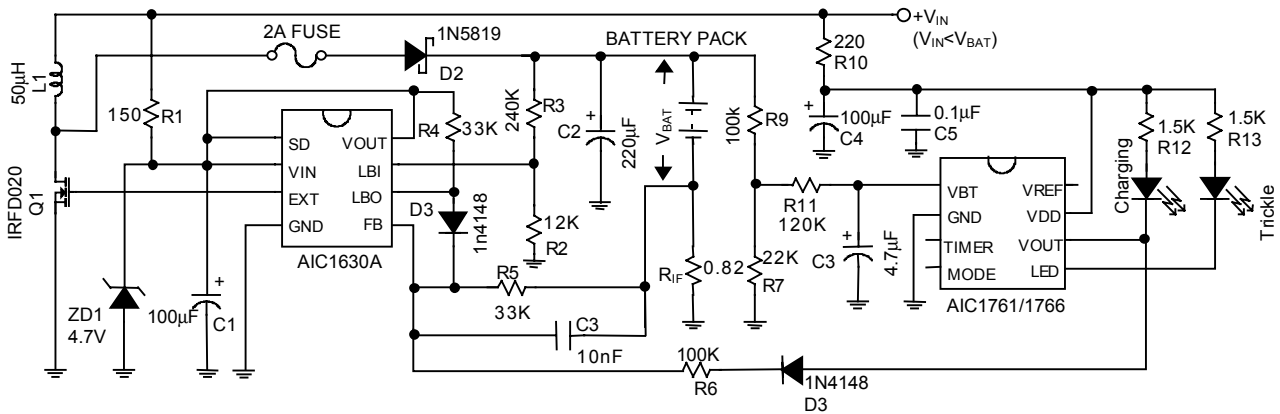

Fig. 8 5V Output Step-Down Converter -2



Note:  $V_{IN} \geq 2.2V$   
 Charging current = 0.8A, Auto-Cut-Off at 0.75/0.25%  $-\Delta V$  point and Fault Conditions.  
 ( $R_{IF}$  sets the Charging Current)  
 $V_{IN}$  must be lower than  $V_{BAT}$ .  
 Short Circuit Condition is protected with a 2A Fuse.

Fig. 9 Step-Up Rechargeable Battery Charger





**APPLICATION EXAMPLES (CONTINUED)**

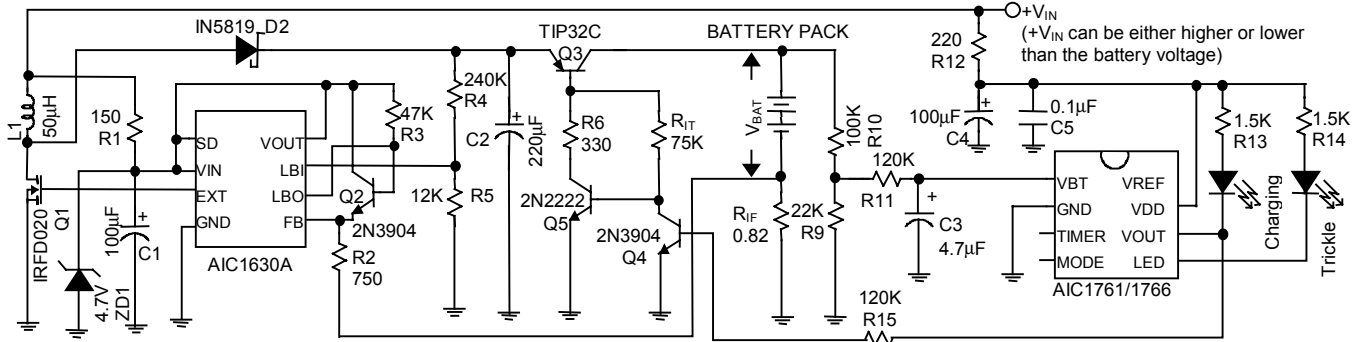

Note: Fast Charge Current =  $0.8A @ V_{IN} < V_{BAT}$   
 $= (V_{IN} - V_{BAT} - 0.5) / 0.82 @ V_{IN} > V_{BAT}$   
 Trickle charge Current = 30mA.  
 ( $R_{IF}$  sets Fast Charge Current,  $R_{IT}$  sets Trickle Charge Current)  
 Typical Efficiency = 75%.  
 With Short Circuit Protection.

**Fig. 10 Step-Up/Down Rechargeable Battery Charger**

**PHYSICAL DIMENSIONS**

● 8 LEAD PLASTIC DIP

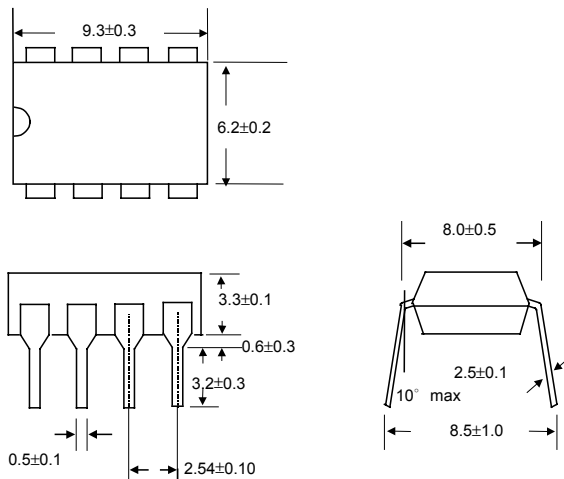

● 8 LEAD PLASTIC SO

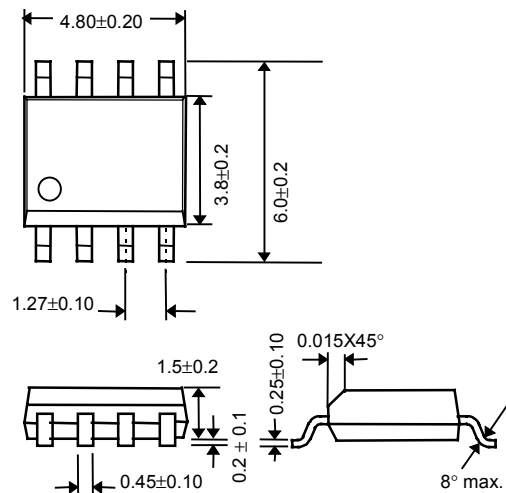

UNIT: mm