

TOSHIBA CMOS Digital Integrated Circuit Silicon Monolithic

TC74VHCT367AF, TC74VHCT367AFN, TC74VHCT367AFT

Hex Bus Buffer

TC74VHCT367AF/AFN/AFT Non-Inverted,
3-State Outputs

Note: xxxFN (JEDEC SOP) is not available in Japan.

The TC74VHCT367A is advanced high speed CMOS HEX BUS BUFFERS fabricated with silicon gate C²MOS technology.

They achieve the high speed operation similar to equivalent Bipolar Schottky TTL while maintaining the CMOS low power dissipation.

They contain six buffers ;four buffers are controlled by an enable input ($\overline{G1}$), and the other two buffers are controlled by another enable input ($\overline{G2}$). The outputs of each buffer group are enabled when $\overline{G1}$ and/or $\overline{G2}$ inputs are held low; if held high, these outputs are in a high impedance state.

The TC74VHCT367A is a non-inverting output type.

Input protection and output circuit ensure that 0 to 5.5 V can be applied to the input and output ^(Note) pins without regard to the supply voltage. These structure prevents device destruction due to mismatched supply and input/output voltages such as battery back up, hot board insertion, etc.

Note: Output in off-state

Features

- High speed: $t_{pd} = 4.7$ ns (typ.) at $V_{CC} = 5$ V
- Low power dissipation: $I_{CC} = 4$ μ A (max) at $T_a = 25^\circ$ C
- Compatible with TTL outputs: $V_{IL} = 0.8$ V (max)
 $V_{IH} = 2.0$ V (min)
- Power down protection is provided on all inputs and outputs.
- Balanced propagation delays: $t_{pLH} \approx t_{pHL}$
- Low noise: $V_{OLP} = 0.8$ V (max)
- Pin and function compatible with the 74ALS367.

TC74VHCT367AF

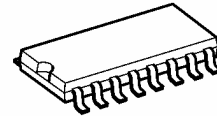

SOP16-P-300-1.27A

TC74VHCT367AFN

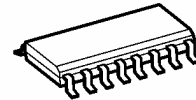

SOL16-P-150-1.27

TC74VHCT367AFT

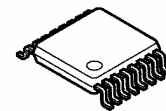

TSSOP16-P-0044-0.65A

Weight

SOP16-P-300-1.27A	: 0.18 g (typ.)
SOL16-P-150-1.27	: 0.13 g (typ.)
TSSOP16-P-0044-0.65A	: 0.06 g (typ.)

Pin Assignment

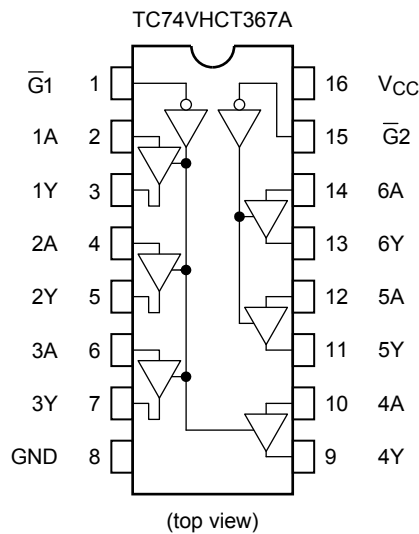

IEC Logic Symbol

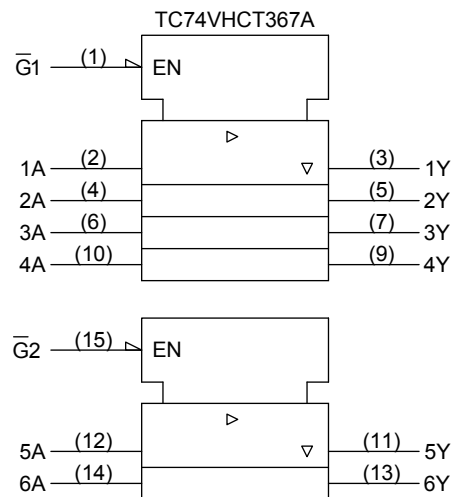

Truth Table

Inputs		Output
\bar{G}	A	Y
L	L	L
L	H	H
H	X	Z

X: Don't care

Z: High impedance

Absolute Maximum Ratings (Note 1)

Characteristics	Symbol	Rating	Unit
Supply voltage range	V_{CC}	-0.5 to 7.0	V
DC input voltage	V_{IN}	-0.5 to 7.0	V
DC output voltage	V_{OUT}	-0.5 to 7.0 (Note 2)	V
		-0.5 to $V_{CC} + 0.5$ (Note 3)	
Input diode current	I_{IK}	-20	mA
Output diode current	I_{OK}	±20 (Note 4)	mA
DC output current	I_{OUT}	±25	mA
DC V_{CC} /ground current	I_{CC}	±50	mA
Power dissipation	P_D	180	mW
Storage temperature	T_{stg}	-65 to 150	°C

Note 1: Exceeding any of the absolute maximum ratings, even briefly, lead to deterioration in IC performance or even destruction.

Using continuously under heavy loads (e.g. the application of high temperature/current/voltage and the significant change in temperature, etc.) may cause this product to decrease in the reliability significantly even if the operating conditions (i.e. operating temperature/current/voltage, etc.) are within the absolute maximum ratings and the operating ranges.

Please design the appropriate reliability upon reviewing the Toshiba Semiconductor Reliability Handbook ("Handling Precautions"/"Derating Concept and Methods") and individual reliability data (i.e. reliability test report and estimated failure rate, etc.).

Note 2: Output in Off-State

Note 3: High or low state. I_{OUT} absolute maximum rating must be observed.

Note 4: $V_{OUT} < GND$, $V_{OUT} > V_{CC}$

Operating Ranges (Note 1)

Characteristics	Symbol	Rating	Unit
Supply voltage	V_{CC}	4.5 to 5.5	V
Input voltage	V_{IN}	0 to 5.5	V
Output voltage	V_{OUT}	0 to 5.5 (Note 2)	V
		0 to V_{CC} (Note 3)	
Operating temperature	T_{opr}	-40 to 85	°C
Input rise and fall time	dt/dV	0 to 20	ns/V

Note 1: The operating ranges must be maintained to ensure the normal operation of the device.
Unused inputs must be tied to either VCC or GND.

Note 2: Output in Off-State

Note 3: High or low state.

Electrical Characteristics

DC Characteristics

Characteristics	Symbol	Test Condition	Ta = 25°C			Ta = -40 to 85°C		Unit		
			VCC (V)	Min	Typ.	Max	Min		Max	
High-level input voltage	V_{IH}	—	4.5 to 5.5	2.0	—	—	2.0	—	V	
Low-level input voltage	V_{IL}	—	4.5 to 5.5	—	—	0.8	—	0.8	V	
High-level output voltage	V_{OH}	$V_{IN} = V_{IH}$ or V_{IL}	$I_{OH} = -50 \mu A$	4.5	4.40	4.50	—	4.40	—	V
			$I_{OH} = -8 \text{ mA}$	4.5	3.94	—	—	3.80	—	
Low-level output voltage	V_{OL}	$V_{IN} = V_{IH}$ or V_{IL}	$I_{OL} = 50 \mu A$	4.5	—	0.0	0.10	—	0.10	V
			$I_{OL} = 8 \text{ mA}$	4.5	—	—	0.36	—	0.44	
3-state output off-state current	I_{OZ}	$V_{IN} = V_{IH}$ or V_{IL} $V_{OUT} = V_{CC}$ or GND	5.5	—	—	±0.25	—	±2.50	μA	
Input leakage current	I_{IN}	$V_{IN} = 5.5 \text{ V}$ or GND	0 to 5.5	—	—	±0.1	—	±1.0	μA	
Quiescent supply current	I_{CC}	$V_{IN} = V_{CC}$ or GND	5.5	—	—	4.0	—	40.0	μA	
	I_{CCT}	Per input: $V_{IN} = 3.4 \text{ V}$ Other input: V_{CC} or GND	5.5	—	—	1.35	—	1.50	mA	
Output leakage current	I_{OPD}	$V_{OUT} = 5.5 \text{ V}$	0	—	—	+0.5	—	+5.0	μA	

AC Characteristics (input: $t_r = t_f = 3$ ns)

Characteristics	Symbol	Test Condition	Ta = 25°C			Ta = -40 to 85°C		Unit		
			V _{CC} (V)	C _L (pF)	Min	Typ.	Max		Min	Max
Propagation delay time	t _{pLH}	—	5.0 ± 0.5	15	—	4.7	7.4	1.0	8.5	ns
	t _{pHL}			50	—	5.2	8.4	1.0	9.5	
3-state output enable time	t _{pZL}	R _L = 1kΩ	5.0 ± 0.5	15	—	4.9	10.4	1.0	12.0	ns
	t _{pZH}			50	—	5.4	11.4	1.0	13.0	
3-state output disable time	t _{pLZ} t _{pHZ}	R _L = 1kΩ	5.0 ± 0.5	50	—	6.3	11.4	1.0	13.0	ns
Output to output skew	t _{osLH} t _{osHL}	(Note 1)	5.0 ± 0.5	50	—	—	1.0	—	1.0	ns
Input capacitance	C _{IN}	—	—	—	—	4	10	—	10	pF
Output capacitance	C _{OUT}	—	—	—	—	6	—	—	—	pF
Power dissipation capacitance	C _{PD}	—	—	(Note 2)	—	16	—	—	—	pF

Note 1: Parameter guaranteed by design.

$$t_{osLH} = |t_{pLHm} - t_{pLHn}|, t_{osHL} = |t_{pHLm} - t_{pHLn}|$$

Note 2: C_{PD} is defined as the value of the internal equivalent capacitance which is calculated from the operating current consumption without load.

Average operating current can be obtained by the equation:

$$I_{CC(opr)} = C_{PD} \cdot V_{CC} \cdot f_{IN} + I_{CC}/6 \text{ (per bit)}$$

Noise Characteristics (input: $t_r = t_f = 3$ ns)

Characteristics	Symbol	Test Condition	Ta = 25°C			Unit
			V _{CC} (V)	Typ.	Max	
Quiet output maximum dynamic V _{OL}	V _{OLP}	C _L = 50 pF	5.0	0.6	0.8	V
Quiet output minimum dynamic V _{OL}	V _{OLV}	C _L = 50 pF	5.0	-0.6	-0.8	V
Minimum high level dynamic input voltage	V _{IHD}	C _L = 50 pF	5.0	—	2.0	V
Maximum low level dynamic input voltage	V _{ILD}	C _L = 50 pF	5.0	—	0.8	V

Package Dimensions

SOP16-P-300-1.27A

Unit: mm

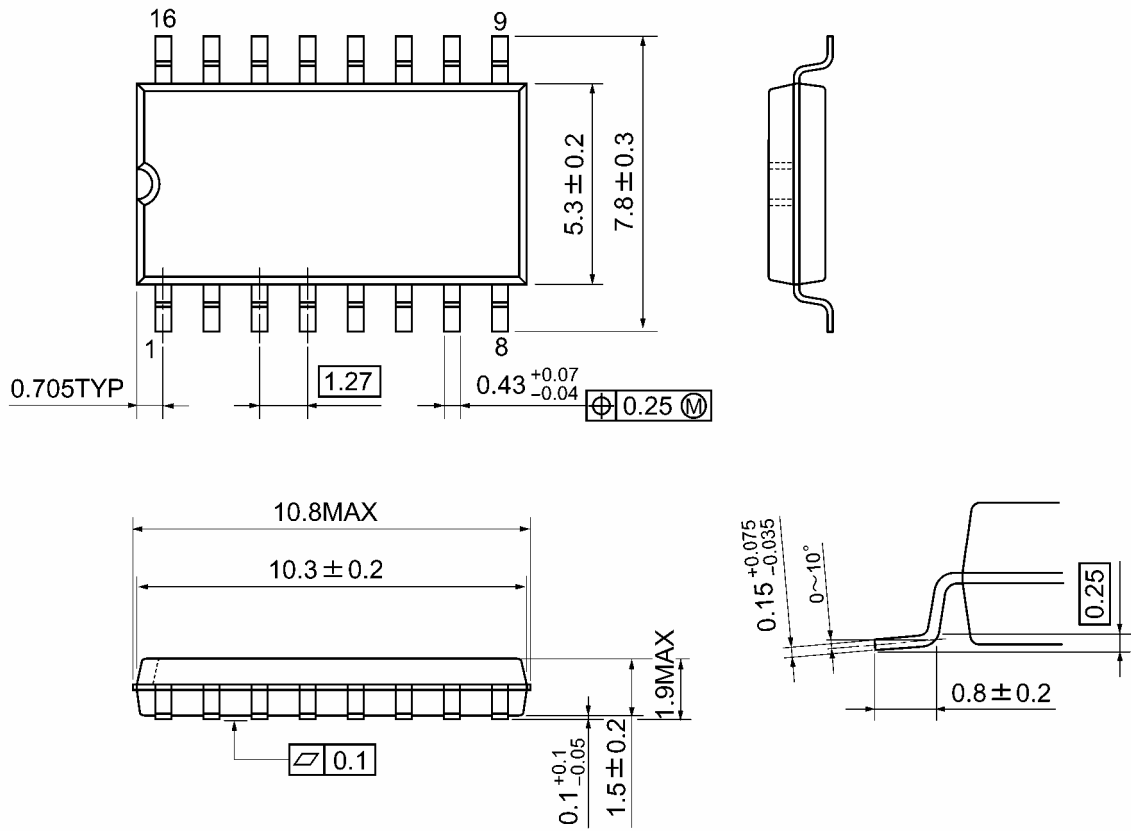

Weight: 0.18 g (typ.)

Package Dimensions (Note)

SOL16-P-150-1.27

Unit : mm

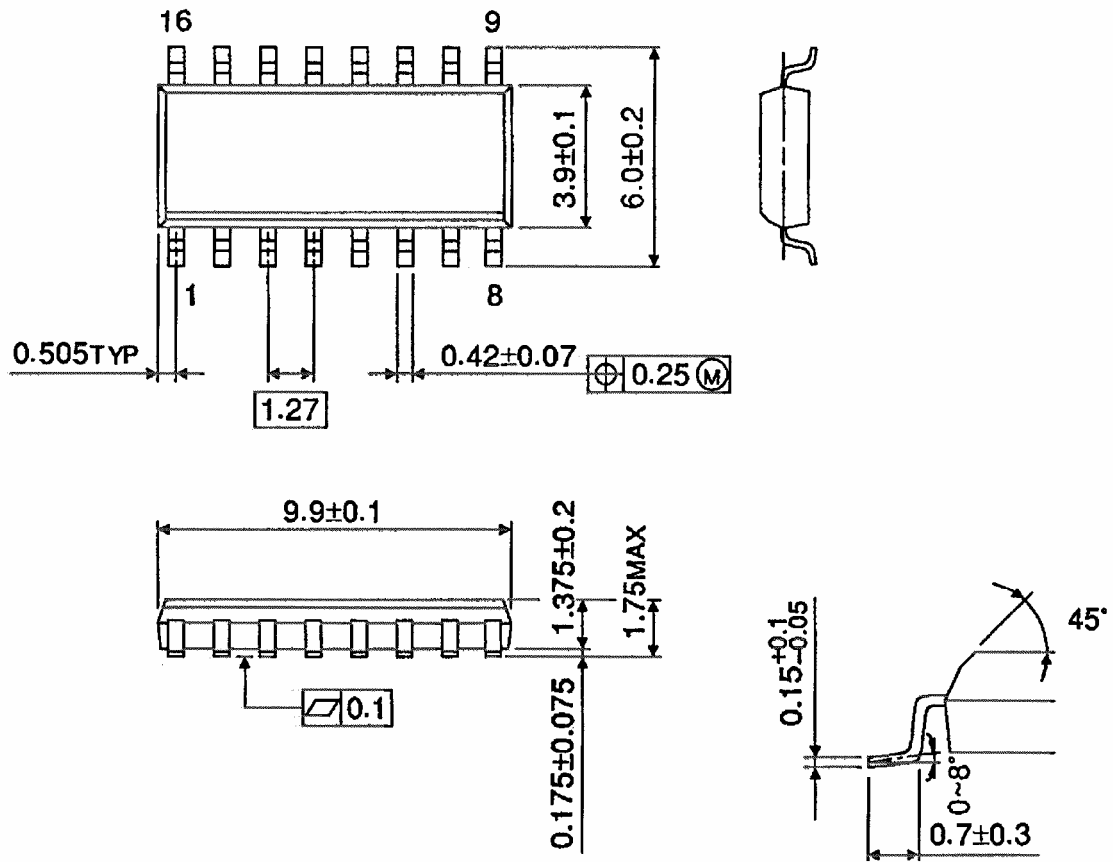

Note: This package is not available in Japan.

Weight: 0.13 g (typ.)

Package Dimensions

TSSOP16-P-0044-0.65A

Unit: mm

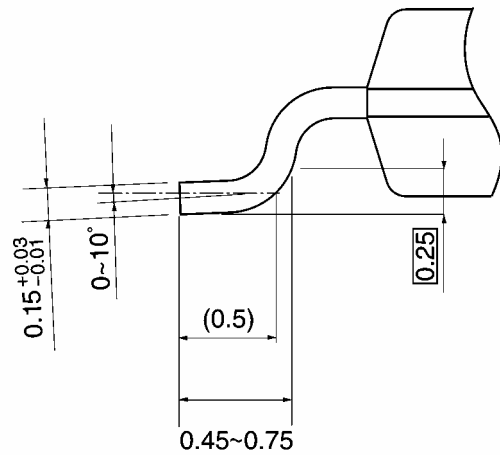
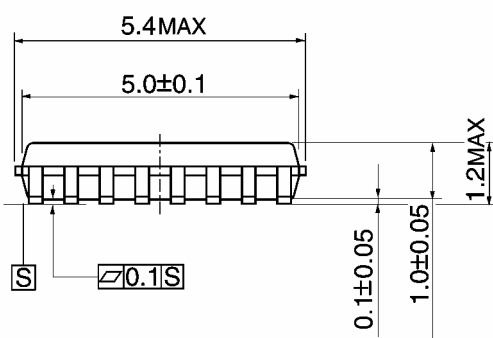
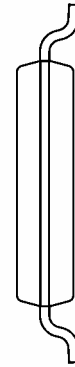
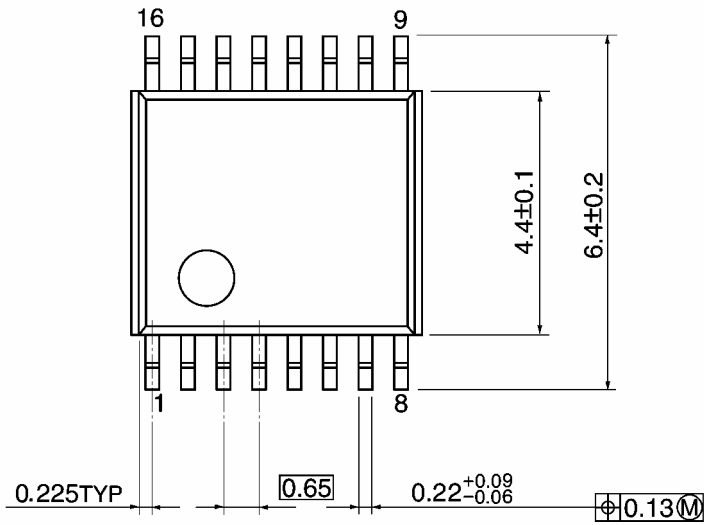

Weight: 0.06 g (typ.)

RESTRICTIONS ON PRODUCT USE

20070701-EN GENERAL

- The information contained herein is subject to change without notice.
- TOSHIBA is continually working to improve the quality and reliability of its products. Nevertheless, semiconductor devices in general can malfunction or fail due to their inherent electrical sensitivity and vulnerability to physical stress. It is the responsibility of the buyer, when utilizing TOSHIBA products, to comply with the standards of safety in making a safe design for the entire system, and to avoid situations in which a malfunction or failure of such TOSHIBA products could cause loss of human life, bodily injury or damage to property.
In developing your designs, please ensure that TOSHIBA products are used within specified operating ranges as set forth in the most recent TOSHIBA products specifications. Also, please keep in mind the precautions and conditions set forth in the "Handling Guide for Semiconductor Devices," or "TOSHIBA Semiconductor Reliability Handbook" etc.
- The TOSHIBA products listed in this document are intended for usage in general electronics applications (computer, personal equipment, office equipment, measuring equipment, industrial robotics, domestic appliances, etc.). These TOSHIBA products are neither intended nor warranted for usage in equipment that requires extraordinarily high quality and/or reliability or a malfunction or failure of which may cause loss of human life or bodily injury ("Unintended Usage"). Unintended Usage include atomic energy control instruments, airplane or spaceship instruments, transportation instruments, traffic signal instruments, combustion control instruments, medical instruments, all types of safety devices, etc.. Unintended Usage of TOSHIBA products listed in this document shall be made at the customer's own risk.
- The products described in this document shall not be used or embedded to any downstream products of which manufacture, use and/or sale are prohibited under any applicable laws and regulations.
- The information contained herein is presented only as a guide for the applications of our products. No responsibility is assumed by TOSHIBA for any infringements of patents or other rights of the third parties which may result from its use. No license is granted by implication or otherwise under any patents or other rights of TOSHIBA or the third parties.
- Please contact your sales representative for product-by-product details in this document regarding RoHS compatibility. Please use these products in this document in compliance with all applicable laws and regulations that regulate the inclusion or use of controlled substances. Toshiba assumes no liability for damage or losses occurring as a result of noncompliance with applicable laws and regulations.