

TPD2004F

2-channel Squib Driver for Air Bags

Manufactured through the Bi-CMOS-DMOS process, this 2-channel squib drive IPD is designed for use in SRS electronic system air bags.

Features

- Using independent four-channel inputs, this IC controls two high-side and two low-side switches, making it possible to drive two squibs directly.
- Incorporates various diagnostic functions (analog multiplexer outputs):
 - Squib short-to-battery diagnosis
 - Squib short-to-ground diagnosis
 - Squib open-circuit diagnosis
 - Safing sensor-ON fault diagnosis
 - High-redundancy, upstream arrangement for safing sensor
 - Squib short diagnosis
 - Squib drive MOSFET diagnosis
- Chip select function allows for multi-channel structure to be materialized using minimum control lines.
- Comes in a 24-pin SSOP surface mount package.
- Supports embossed taping.

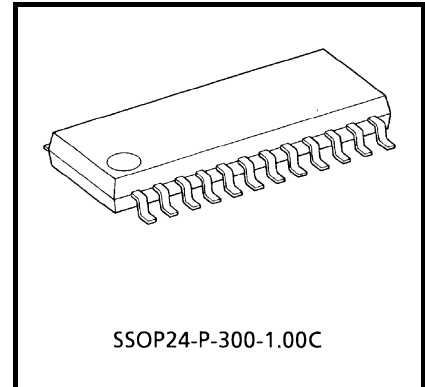

Weight: 0.29g (typ.)

Pin Assignment (top view)

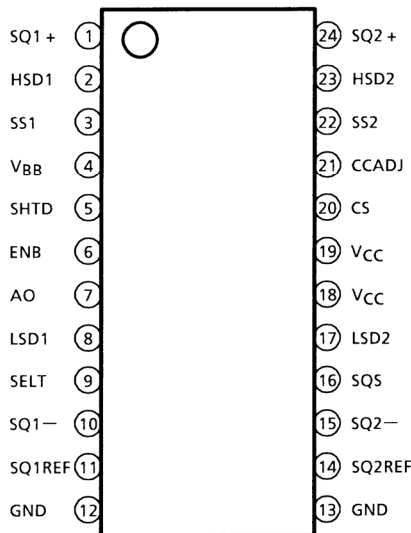

Marking

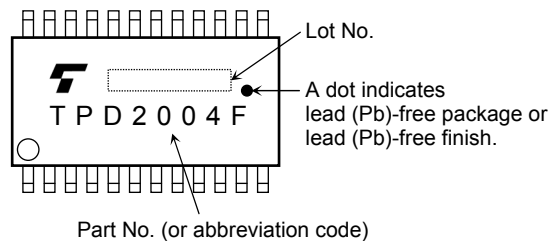

Note: Due to its MOS structure, this product is sensitive to static electricity.

Block Diagram

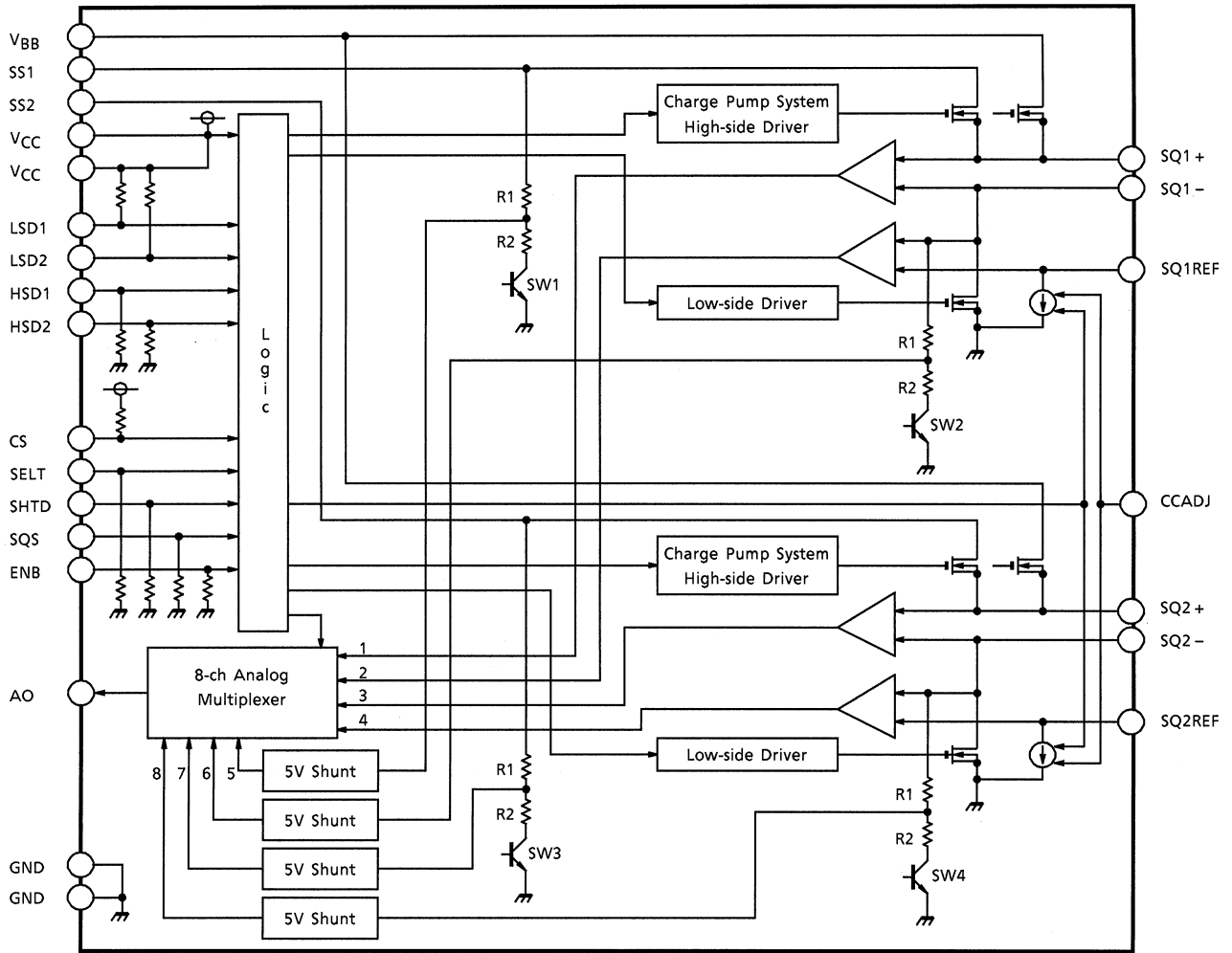

Pin Description

Pin No.	Symbol	Pin Description
1	SQ1+	Squib positive (+) side output pin for channel 1
2	HSD1	High-side driver control input pin for Channel 1 (pull-down)
3	SS1	Safing sensor connect pin for channel 1
4	V _{BB}	Backup block power supply input pin
5	SHTD	Control input pin for short diagnosis (pull-down)
6	ENB	INHIBIT input pin to inhibit ignition when this input is pulled low (pull-down)
7	AO	Analog multiplexer output pin
8	LSD1	Low-side driver control input pin for Channel 1 (pull-up)
9	SELT	Control input pin for switching between diagnosis line and analog multiplexer (pull-down)
10	SQ1-	Squid negative (-) side output pin for channel 1 (shared with reference resistor pin for short diagnosis)
11	SQ1REF	Shorting diagnosis reference resistor pin for channel 1
12, 13	GND	Ground pin (Two pins)
14	SQ2REF	Shorting diagnosis reference resistor pin for Channel 2
15	SQ2-	Squib negative (-) side output pin for channel 2 (shared with reference resistor pin shorting diagnosis)
16	SQS	Squib switchover control input pin during each squib diagnosis (pull-down)
17	LSD2	Low-side driver control input pin for Channel 2 (pull-up)
18, 19	V _{CC}	5V block power supply input pin (two pins)
20	CS	Chip select control input pin (pull-up)
21	CCADJ	Current setup resistor connect pin for short diagnosis constant-current source (reference resistor connect pin)
22	SS2	Safing sensor connect pin for Channel 2
23	HSD2	High-side driver control input pin for Channel 2 (pull-down)
24	SQ2+	Squib positive (+) side output pin for Channel 2

Truth Table

State	SQUIB	HSD1	HSD2	LSD1	LSD2	SELT	SHTD	SQS	ENB	CS	MULTI- LEXER ch	DIVIDING VOLTAGE SW
Ignition	SQ1	H	*	L	*	*	*	*	H	*	—	—
	SQ2	*	H	*	L	*	*	*	H	*	—	—
Short Diagnosis	SQ1	L	L	H	H	L	H	L	H	L	1	—
	SQ1	L	L	H	H	H	H	L	H	L	2	—
	SQ2	L	L	H	H	L	H	H	H	L	3	—
	SQ2	L	L	H	H	H	H	H	H	L	4	—
SS1 Potential Diagnosis (Not Divided)	SQ1	L	L	H	H	H	L	L	L	L	5	—
SS2 Potential Diagnosis (Not Divided)	SQ2	L	L	H	H	H	L	H	L	L	7	—
SS1 Potential Diagnosis (Divided)	SQ1	L	L	H	H	H	L	L	H	L	5	SW1
SS2 Potential Diagnosis (Divided)	SQ2	L	L	H	H	H	L	H	H	L	7	SW3
SQ-1 Potential Diagnosis (Not Divided)	SQ1	L	L	H	H	L	L	L	H	L	6	—
SQ-2 Potential Diagnosis (Not Divided)	SQ2	L	L	H	H	L	L	H	H	L	8	—
SQ-1 Potential Diagnosis (Divided)	SQ1	L	L	H	H	L	L	L	L	L	6	SW2
SQ-2 Potential Diagnosis (Divided)	SQ2	L	L	H	H	L	L	H	L	L	8	SW4
High-side Driver Diagnosis	SQ1	H	L	H	H	L	L	L	H	L	6	SW2
	SQ2	L	H	H	H	L	L	H	H	L	8	SW4
Low-side Driver Diagnosis	SQ1	L	L	L	H	L	L	L	H	L	6	—
	SQ2	L	L	H	L	L	L	H	H	L	8	—

*: Don't Care

Note: When ENB input is pulled low, ignition is inhibited.

Note: When CS is high, the diagnostic inputs SELT, SHTD, and SQS are ignored (in logic) and the AO pin is placed in the high-impedance state.

Note: If ignited under shorted condition, the device may break down.

Functional Description

- (1) 2-channel squib drive function
Using independent four-channel inputs, this IC controls two high-side and two low-side switches, making it possible to drive two squibs directly.
- (2) Squib line short-to-battery, short-to-ground and open-circuit diagnostic function (diagnostic voltage output)
When the squib is in normal state, by an external diagnostic resistor, the device outputs a voltage derived from VCC by dividing it according to the resistance ratio. Because this voltage is output via the analog multiplexer, it is possible to diagnose short-to-battery, short-to-ground and open-circuit in the squib line using a microcomputer. Also, the device contains a shunt circuit to prevent the analog multiplexer from breaking down when the squib is short-to-battery.
- (3) Squib short diagnostic function (diagnostic voltage output)
A diagnostic current is flowed from the internal constant-current source to the squib and reference resistor, and the voltage drop in each is amplified by an internal amp whose gain is the same for both. These voltages are output via the analog multiplexer, so that the squib resistance value can be diagnosed by a microcomputer. Also, the relative accuracy of the output voltages is guaranteed to be within $\pm 10\%$.
- (4) Squib driver MOSFET diagnostic function (diagnostic voltage output)
When the squib driver is turned on while the safing sensor is in normal state, the drain voltage of the MOSFET is output via the analog multiplexer, making it possible to diagnose the state of the MOSFET using a microcomputer.
- (5) Diagnostic chip select function
Since the device has a chip select function, the diagnostic control bits can be minimized when the application circuit is configured with multiple chips. Furthermore, when a chip is not selected, the diagnostic output pin AO is placed in the high-impedance state; therefore it is possible to diagnose multiple chips using a 1-channel CPU A/D port. (Ignition operates irrespective of CS.)
- (6) Input INHIBIT function
The purpose of this function is to prevent erroneous ignition due to a fault in the microcomputer or the system power supply. It allows for ignition to be inhibited by pulling the ENB pin low.

Absolute Maximum Rating (Ta = -40~85°C)

Characteristics	Symbol	Rating	Unit
Power Supply Voltage	V _{BB}	30	V
	V _{CC}	10	
Input Voltage	SS	30	V
	V _{IN}	-0.5~7	
Backup Capacitor Capacitance	CM	1500 (1ch)	μF
Backup Capacitor Charging Voltage	CV	25	V
Squib ON-Time	t _{ON}	15	ms
Squib Driver Current (channel)	I _{SQ}	10	A
Power Dissipation	P _D	0.8	W
Operating Temperature	T _{opr}	-40~85	°C
Junction Temperature	T _j	150	°C
Storage Temperature	T _{stg}	-55~150	°C

Note1: The squib driver uses a 60V tolerant output device. However, this does not guarantee that the squib tolerates 60V because this varies with the withstand voltages of peripheral circuits.

Note2: Using continuously under heavy loads (e.g. the application of high temperature/current/voltage and the significant change in temperature, etc.) may cause this product to decrease in the reliability significantly even if the operating conditions (i.e. operating temperature/current/voltage, etc.) are within the absolute maximum ratings and the operating ranges.

Please design the appropriate reliability upon reviewing the Toshiba Semiconductor Reliability Handbook ("Handling Precautions"/Derating Concept and Methods) and individual reliability data (i.e. reliability test report and estimated failure rate, etc).

Electrical Characteristics (T_j = -40~85°C)

Characteristics		Symbol	Test Condition	Min	Typ.	Max	Unit	
Operating Supply Voltage		V _{BB}	—	4	—	25	V	
		V _{CC}	—	4.75	—	5.25		
Supply Current		I _{BB}	V _{BB} = 24V, when diagnosed, C _{CRef} = 20kΩ	—	35	100	mA	
			V _{BB} = 24V, when not diagnosed	—	0.1	1		
		I _{CC}	V _{CC} = 5.25V, when diagnosed	—	5	10		
			V _{CC} = 5.25V, when not diagnosed	—	3	6		
Input Voltage		V _{IL}	INPUT "L"	—	—	V _{CC} × 0.3	V	
		V _{IH}	INPUT "H"	V _{CC} × 0.7	—	—		
Input Current		I _{IL}	V _{IN} = 0V (Pull-down)	—	—	±10	μA	
			V _{IN} = 0V (Pull-up)	—	-50	-200		
		I _{IH}	V _{IN} = V _{CC} (Pull-down)	—	50	200		
			V _{IN} = V _{CC} (Pull-up)	—	—	±10		
Squib Driver ON-Resistance		R _{DS (ON) SQ}	V _{BB} = 9V, V _{CC} = 4.75V, I _D = 1A	—	0.6	1	Ω	
			V _{BB} = 9V, V _{CC} = 4.75V, I _D = 3A	—	0.7	1.2		
Squib Driver Output Leakage Current		High Side	I _{OLSQ (H)}	V _{OUT} = 25V	—	—	mA	
		Low Side	I _{OLSQ (L)}	V _{OUT} = V _{CC}	—	—		0.1
				V _{OUT} = 25V	—	—		1
Diagnostic Amp Amplification Factor		AMPGAIN	V _{CC} = 4.75V, AMPVCOMM = 3V, T _j = 25°C	18	20	22		
Diagnostic Amp Offset Voltage		AMPOFFSET	V _{CC} = 4.75V, AMPVCOMM = 3V, T _j = 25°C	—	—	±10	mV	
Diagnostic Amp Differential Input Voltage Range		AMPVDEF	V _{CC} = 4.75V, I _{SH} = 100mA, AMPVCOMM = 3V, T _j = 25°C	200	—	—	mV	
Diagnostic Amp In-phase Input Voltage Range		AMPVCOMM	—	3.0	—	—	V	
Diagnostic Amp Output Saturation Voltage		V _{AMPSAT}	—	V _{CC} -1	—	—	V	
Diagnostic Constant-current Source		I _{SHDIAGCC}	C _{CRef} = 20kΩ	28	35	45	mA	
Diagnostic Output Voltage		V _{DIAGSQ}	R _{SQ} = 2Ω, I _{SH} = 35mA, I _{AO} = 5μA	900	1400	1900	mV	
		V _{DIAGREF}	R _{REF} = 2Ω, I _{SH} = 35mA, I _{AO} = 5μA	900	1400	1900		
Diagnostic Output Relative Accuracy		V _{DIAGDEV}	R _{SQ} = R _{REF} = 2Ω, I _{SH} = 35mA, I _{AO} = 5μA	-10	0	10	%	

Characteristics		Symbol	Test Condition	Min	Typ.	Max	Unit
Diagnostic Resistance Value		R1	—	40	80	280	kΩ
		R2	—	10	20	70	
Diagnostic Voltage Dividing Ratio		V _{DIV}	—	0.17	0.2	0.23	—
Diagnostic Resistance Relative Accuracy		R _{DEV}	(Measured between SS1, SQ1-, SS2, SQ2-)	-5	0	5	%
Switching Time (High-side SW)		T _{PLH}	V _{BB} = 25V, R _{load} , I _D = 3A	—	100	200	μs
		T _{PHL}		—	10	50	
Switching Time (Low-side SW)		T _{PLH}		—	10	50	
		T _{PHL}		—	10	50	
Diagnosis Switchover Time	High-side Driver Diagnosis	T _{DLH}	V _{BB} = 25V, R _{load} , R = 2Ω	—	120	250	μs
		T _{DHL}		—	50	100	
	Low-side Driver Diagnosis	T _{DLH}		—	20	80	
		T _{DHL}		—	40	80	
	Other Diagnosis	T _{DLH}		—	30	60	
		T _{DHL}		—	50	100	

Note: The short diagnosis monitor current in cases when the CCADJ pin is shorted to GND is 100mA (max) (at all temperatures).

Note: Short diagnosis must be completed within 15ms.

Package Dimensions

SSOP24-P-300-1.00C

Unit : mm

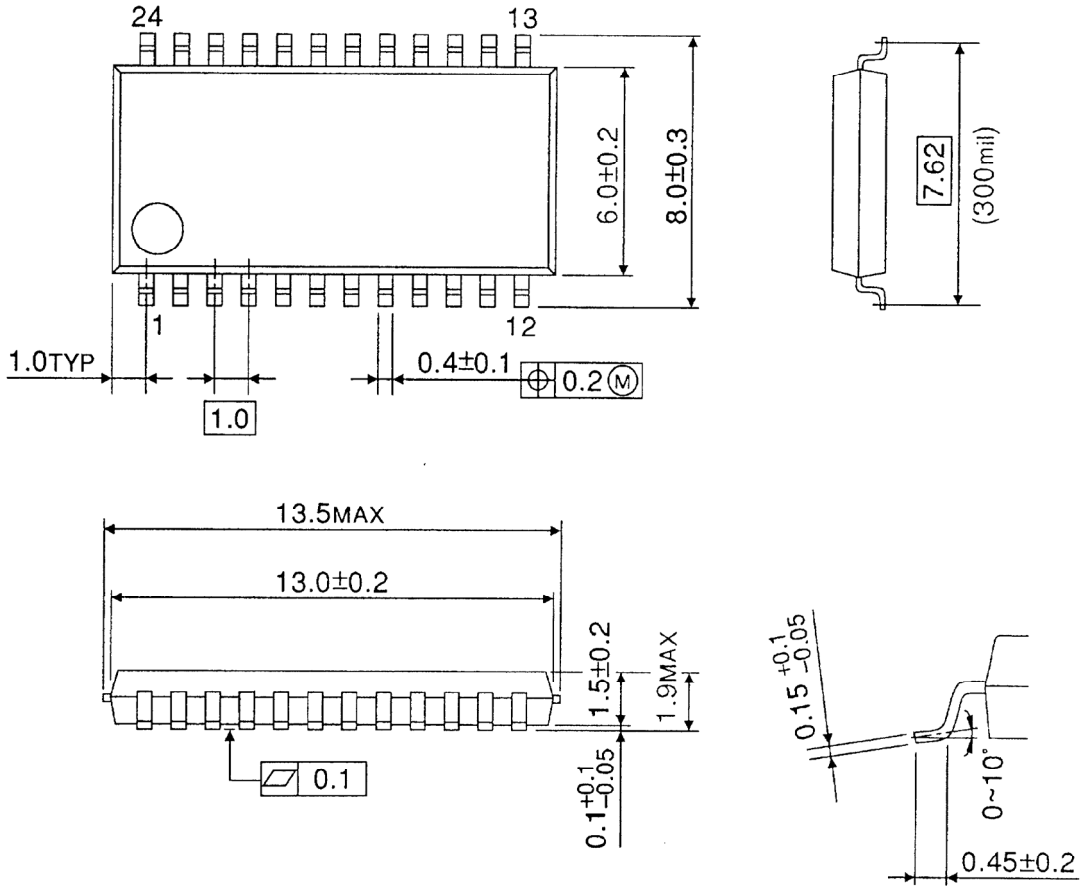

Weight: 0.29g (typ.)

RESTRICTIONS ON PRODUCT USE

20070701-EN

- The information contained herein is subject to change without notice.
- TOSHIBA is continually working to improve the quality and reliability of its products. Nevertheless, semiconductor devices in general can malfunction or fail due to their inherent electrical sensitivity and vulnerability to physical stress. It is the responsibility of the buyer, when utilizing TOSHIBA products, to comply with the standards of safety in making a safe design for the entire system, and to avoid situations in which a malfunction or failure of such TOSHIBA products could cause loss of human life, bodily injury or damage to property.
In developing your designs, please ensure that TOSHIBA products are used within specified operating ranges as set forth in the most recent TOSHIBA products specifications. Also, please keep in mind the precautions and conditions set forth in the "Handling Guide for Semiconductor Devices," or "TOSHIBA Semiconductor Reliability Handbook" etc.
- The TOSHIBA products listed in this document are intended for usage in general electronics applications (computer, personal equipment, office equipment, measuring equipment, industrial robotics, domestic appliances, etc.). These TOSHIBA products are neither intended nor warranted for usage in equipment that requires extraordinarily high quality and/or reliability or a malfunction or failure of which may cause loss of human life or bodily injury ("Unintended Usage"). Unintended Usage include atomic energy control instruments, airplane or spaceship instruments, transportation instruments, traffic signal instruments, combustion control instruments, medical instruments, all types of safety devices, etc.. Unintended Usage of TOSHIBA products listed in this document shall be made at the customer's own risk.
- The products described in this document shall not be used or embedded to any downstream products of which manufacture, use and/or sale are prohibited under any applicable laws and regulations.
- The information contained herein is presented only as a guide for the applications of our products. No responsibility is assumed by TOSHIBA for any infringements of patents or other rights of the third parties which may result from its use. No license is granted by implication or otherwise under any patents or other rights of TOSHIBA or the third parties.
- Please contact your sales representative for product-by-product details in this document regarding RoHS compatibility. Please use these products in this document in compliance with all applicable laws and regulations that regulate the inclusion or use of controlled substances. Toshiba assumes no liability for damage or losses occurring as a result of noncompliance with applicable laws and regulations.