

July 20, '99

No. 3284LTD-1295-2

HITACHI

液晶之友 电话: 020-33819057
Http://www.lcdfriends.com

LIQUID CRYSTAL DISPLAY MODULE TECHNICAL DATA

SA09Q001-BZA

(NOTE)

1. This document may, wholly or partially, be subject to change without notice.
2. All rights are reserved ; No one is permitted to reproduce or duplicate, in any form, the whole or part of this document without Hitachi's permission.
3. No one is permitted to explain contents of this document to third parties without Hitachi's permission.
4. Hitachi will not be held responsible for any damage to the user that may result from accidents or any other reasons during operation of the user's unit according to this document, any previous reports or oral discussions.
5. Circuitry and other examples described herein are meant merely to indicate the characteristics and performance of Hitachi's products. Hitachi assumes no responsibility for any intellectual property claims or other problems that may result from applications based on the examples described herein.
6. No license is granted by implication or otherwise under any patents or other rights of any third party or Hitachi, Ltd.
7. LIFE SUPPORT APPLICATIONS : Hitachi's products are not authorized for use in LIFE SUPPORT SYSTEMS.

RECORD OF REVISION

Date	Sheet No.	Summary
July 20, '99	3284LTD-1295-2 Page 2-1/1	2. MECHANICAL DATA (5)Number of Dots : 640 × 3 (R,G,B)(W) × 240 (H) dots → 320 × 3 (R,G,B)(W) × 240 (H) dots

2. MECHANICAL DATA

- (1) Part Name SA09Q001-BZA
- (2) Module Size 104.5(W) mm × 75.4(H) mm × 7.5 max (D) mm
(w ith Frontlight and Touch Panel)
- (3) Dot Size 0.057(W) mm × 0.211(H) mm
- (4) Dot Pitch 0.077(W) mm × 0.231(H) mm
- (5) Number of Dots 320 × 3 (R,G,B)(W) × 240 (H) dots
- (6) Duty 1/242
- (7) LCD Reflective Color LCD (negative type)
The upper polarizer is glare type
- (8) View ing Direction 6 O'clock
- (9) Frontlight Cold Cathode Fluorescent Lamp (CFL) × 1
- (10) Pow er Consumption (35mW) : Frontlight turned off
(410mW) : Frontlight turned on
- (11) Reflectance (20%)
- (12) Weight (65g)
- (13) Pow er Supply Voltage 3.3V only
- (14) Touch panel Resistance type
The surface is glare type

(15) Recommended Controller

Type No.	Supplier	portrait mode operation	Availability
HD64461	Hitachi	Soft w ise	Available
HD64463	Hitachi	Soft w ise	Available
SED1354	Epson	Soft w ise	Available
SED1355	Epson	Hard w ise	Available
SED1374	Epson	Hard w ise	Available

3. ABSOLUTE MAXIMUM RATINGS

3. 1 ELECTRICAL ABSOLUTE MAXIMUM RATINGS OF LCD

VSS=0V

ITEM	SYMBOL	MIN	MAX	UNIT	COMMENT
Power Supply for Logic	VDD	0	4.0	V	
Contrast Adjustment Voltage	VCON	0	VDD	V	
Input Voltage	V _i	-0.3	VDD+0.3	V	Note 1
Input Current	i _i	0	1	A	
Static Electricity	-	-	(±8)	kV	Note 2

Note 1 $\overline{\text{DISP}}\bullet\text{OFF}$, FLM, CL1, CL2, D0~D8

Note 2 200pF-250Ω, 25°C-70%RH, The Surface of metal bezel and LCD panel are subjected.

3. 2 ELECTRICAL ABSOLUTE MAXIMUM RATINGS OF TOUCH PANEL

ITEM	SYMBOL	MIN	MAX	UNIT	COMMENT
Input Voltage	V _{Ti}	-	7	V	
Input Current	I _{Ti}	-	25	mA	

3. 3 ENVIRONMENTAL ABSOLUTE MAXIMUM RATINGS

ITEM	OPERATING		STORAGE		COMMENT
	MIN	MAX	MIN	MAX	
Ambient Temperature	5°C	40°C	-20°C	60°C	Note 2, 3
Humidity	Note 1		Note 1		Without condensation
Vibration	-	2.45 m/s ² (0.25G)	-	11.76 m/s ² (1.2G) Note 5	Note 4
Shock	-	29.4 m/s ² (3G)	-	490 m/s ² (50G) Note 5	XYZ directions
Corrosive Gas	Not Acceptable		Not Acceptable		

Note 1 Ta≤40°C : 85%RH max.

Ta>40°C : Absolute humidity must be lower than the humidity of 85%RH at 40°C.

Note 2 Ta at -20°C ----- <48h, at 60°C ----- <168h

Note 3 Background color changes slightly depending on ambient temperature.
This phenomenon is reversible.

Note 4 5Hz~100Hz (Except resonance frequency)

Note 5 This module should be operated normally after finishing the test.

Note 6 The response time will be slower at 5°C.

4. ELECTRICAL CHARACTERISTICS

4. 1 ELECTRICAL CHARACTERISTICS OF LCD

VSS=0V

ITEM	SYMBOL	CONDITION	MIN	TYP	MAX	UNIT
Power Supply Voltage	VDD	VDD-VSS=3.3V	3.15	3.30	3.45	V
Contrast Adjustment Voltage (Note 1)	VCON	-	1	-	VDD	V
Input Voltage for Logic Circuits (Note 2)	Vi	"H" level	0.8VDD	-	VDD	V
		"L" level	0	-	0.2VDD	
Power Supply Current (Note 3)	IDD	VDD-VSS=3.3V	-	10	(20)	mA
Input Leak Current	I _{con} (Note4)	V _{con} =1~VDD	-	-	±10	μA
	I _{in} (Note2)	V _{in} =VDDorVSS	-	-	±5.0	
Contrast Adjustment Voltage (Note 5)	V _{con}	T _a = 5°C, φ=0°	(1.4)	-	-	V
		T _a =25°C, φ=0°	-	(2.1)	-	
		T _a =40°C, φ=0°	-	-	(2.8)	
Frame Frequency (Note 6)	fFLM	-	70	100	120	Hz

(Note 1) In proportion as the VCON voltage increase the brightness will increase.

(Note 2) DISP OFF, FLM, CL1, CL2, D0~D8

(Note 3) fFLM=100Hz, T_a=25°C, Display pattern:Checker pattern.

(Note 4) VCON

(Note 5) fFLM=100Hz, Duty=1/242

The Contrast Adjustment Voltage is specified as (2.1±0.4)V under the condition when an optimum contrast is obtained by peak contrast.

(Note 6) Need to make sure of flickering and rippling of display when setting the Frame Frequency in your set.

4. 2 ELECTRICAL CHARACTERISTICS OF FRONTLIGHT

ITEM	SYMBOL	MIN	TYP	MAX	UNIT	NOTE
Lamp Voltage	VL	-	(380)	-	Vrms	Ta=25°C
Frequency	fL	(50)	(60)	-	kHz	
Lamp Curren (Note 7)	IL	(0.7)	(1)	(2.5)	mA	Ta=25°C
Starting discharge Voltage	VS (Note 2)	(1000)	-	-	Vrms	Ta=5°C

- (Note 1) Please design your lamp driving circuit (inverter) according to the above specifications, and inform Hitachi of it.
- (Note 2) Starting discharge voltage is increased when LCM is operating at lower temperature. Please check the characteristics of your inverter before applying to your set.
- (Note 3) Average life time of CFL will be decreased when LCM is operating at lower temperature.
- (Note 4) Under lower driving frequency of an inverter, a certain backlight system (CFL & CFL reflection sheet) may generate a sound noise. Before designing the inverter, please consider the driving frequency and the noise.
- (Note 5) When ICFL is used over 5.0mA, it may cause uneven contrast near CFL location, due to heat dispersion from CFL.
- (Note 6) Under lower temperature, please check CFL characteristics on your inverter.
- (Note 7)

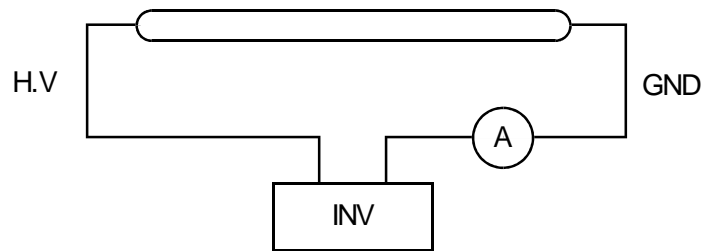

4.3 ELECTRICAL CHARACTERISTICS OF TOUCH PANEL

4.3.1 OPERATING CONDITION

ITEM	SPECIFICATION
Operating Voltage	7VDC
Operating Current	10~25mA

4.3.2 ELECTRICAL CHARACTERISTICS

ITEM		SPECIFICATION	NOTE
Resistance between terminal	X1-X2	0.4~1k Ω	
	Y1-Y2	0.2~0.6k Ω	
Insulance Resistance	X-Y	20M Ω min	Operating Voltage 25VDC
Linearity	X	1.5% max	Measuring every 10mm
	Y	1.5% max	
Chattering		10msec max	

(Note 1) MECHANICAL CHARACTERISTICS

ITEM	SPECIFICATION	NOTE
Pen input pressure	80g max	R0.8, Stylus pen
Surface hardness	2H min	JIS K 5400

5. OPTICAL CHARACTERISTICS

5.1 OPTICAL CHARACTERISTICS OF LCD

Ta=25°C (Frontlight On)

ITEM	SYMBOL	CONDITION	MIN	TYP	MAX	UNIT	NOTE
Reflectance	R	$\phi=0^\circ, \theta=0^\circ$	-	(20)	-	%	1)
Viewing angle	$\phi 2-\phi 1$	$\theta=0^\circ, K \geq 2.0$	-	(60)	-	deg	2),3)
		$\theta=90^\circ, K \geq 2.0$	-	(60)	-		
Contrast ratio	K	$\phi=0^\circ, \theta=0^\circ$ (F/L:turned off)	-	(5.0)	-	-	1),4),6), 7)
		$\phi=0^\circ, \theta=0^\circ$ (F/L:turned on)	-	(4.0)	-		
Response time (rise+fall)	tr+tf	$\phi=0^\circ, \theta=0^\circ$	-	(350)	-	ms	5)

(Measurement condition : Hitachi standard)

Note 2)~7) : See next page.

Note 1. Definition of Reflectance R

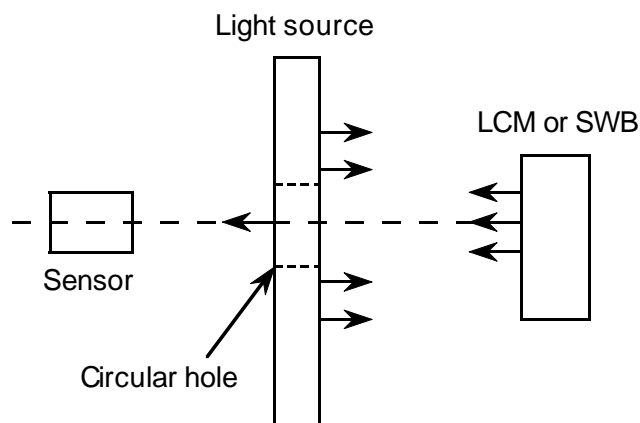

$$R = \frac{BLCM}{BSWB}$$

BLCM : Brightness of LCM at optimum voltage.
(displaying white pattern)

BSWB : Brightness of SWB.

SWB : Standard white board.

Note 2. Definition of θ and ϕ

(Normal)

Viewing direction

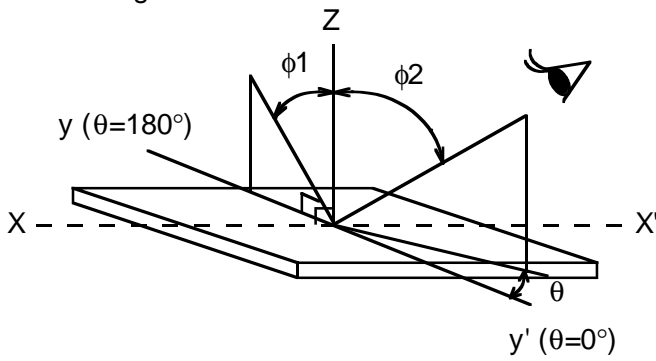

Note 4. Definition of contrast "K"

$$K = \frac{\text{Brightness on selected area (B1)}}{\text{Brightness on non-selected area (B2)}}$$

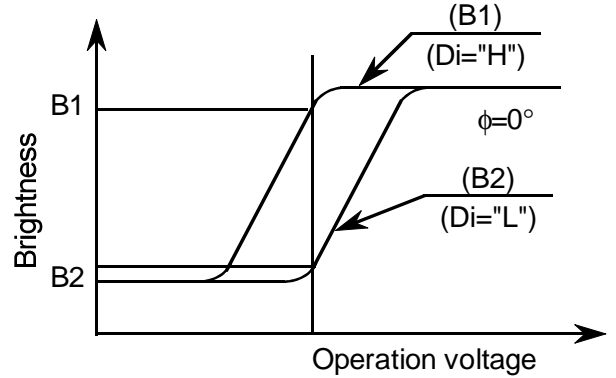

Note 3. Definition of view ing angle ϕ_1 and ϕ_2

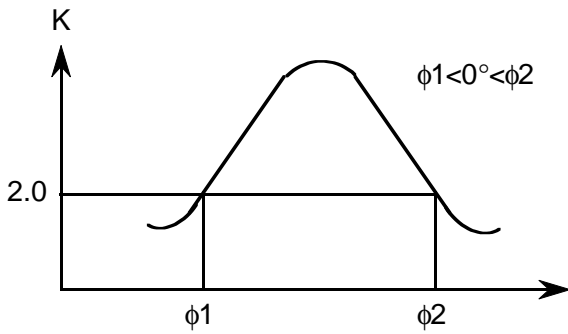

Contrast ratio K vs view ing angle ϕ

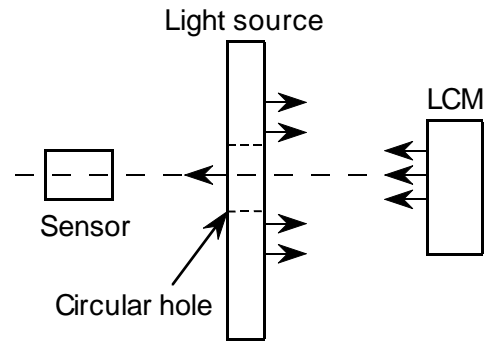

Sensor : BM-5 or correspondence equipment

Note 5. Definition of optical response time

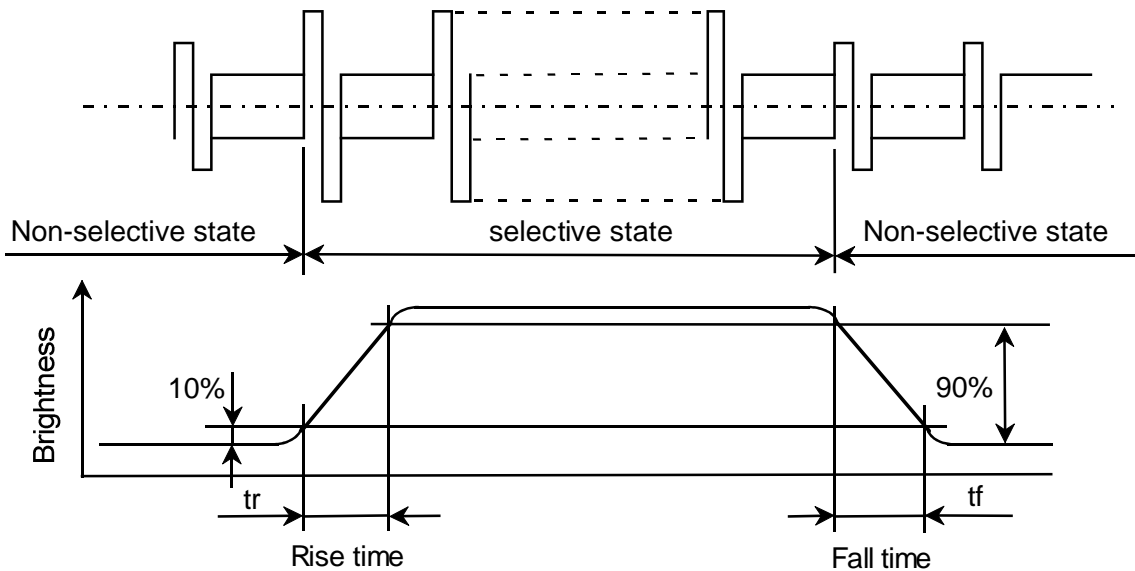

Note 6. Hitachi will not do 100% inspection for minimum value. Minimum value is for reference.

Note 7. Hitachi will do sampling inspection for minimum value.

5.2 OPTICAL CHARACTERISTICS OF FRONTLIGHT WITH TOUCH PANEL

ITEM	MIN	TYP	MAX	UNIT	NOTE
Brightness	(10)	(15)	-	cd/m ²	IL=1.0mA Note 1),2)
Rise Time	-	5	-	Minute	IL=1.0mA Note 1) Brightness 80%

(Measurement condition : Hitachi standard)

(Note 1) Ta=25°C

Display data should be all "ON"

The LCD driving voltage should be adjusted at the voltage where the optimum contrast is obtained, when set pattern is all "Q".

(Note 2) Measurement after 10 minutes from CFL operating.

6. BLOCK DIAGRAM

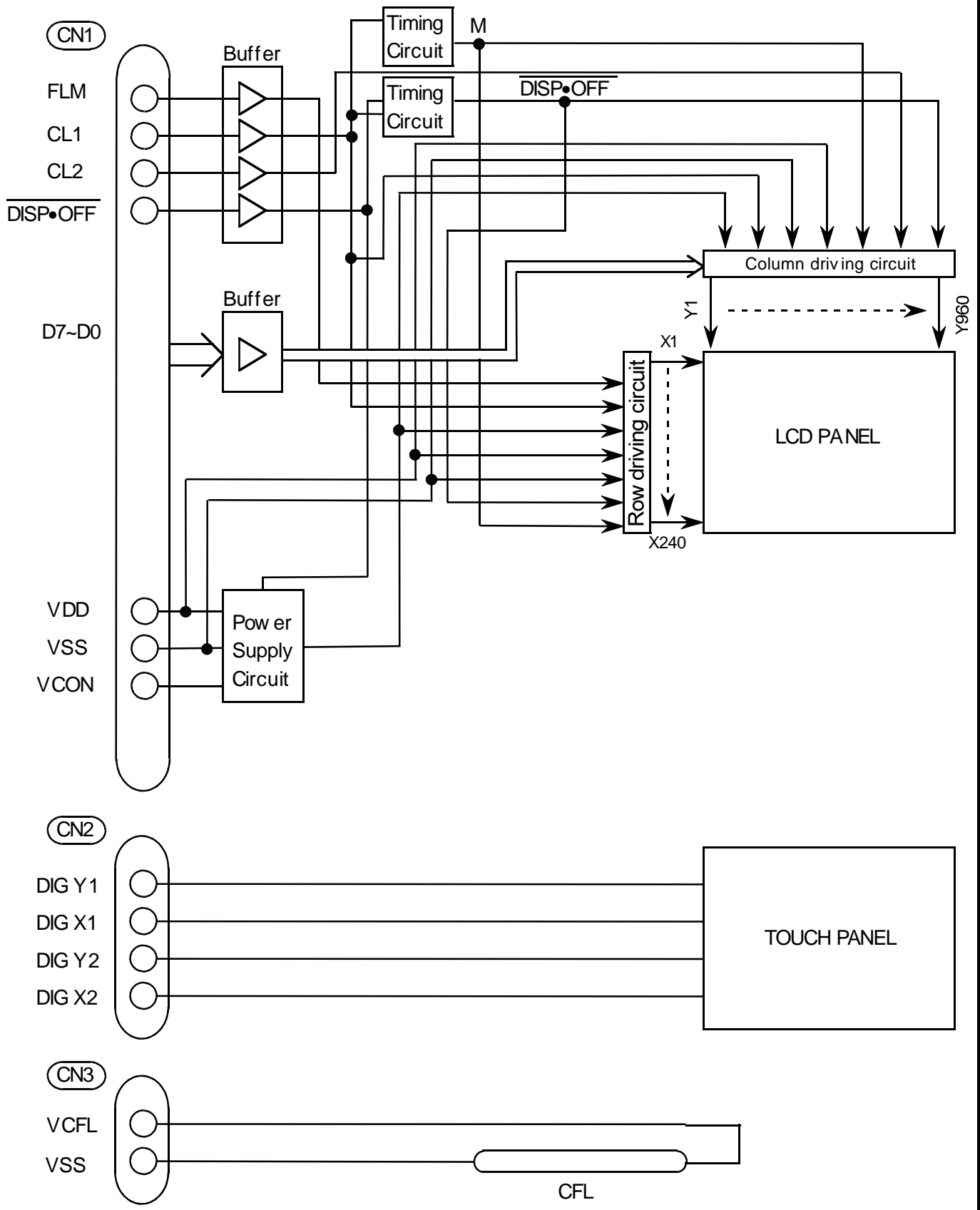

7. INTERFACE TIMING CHART

7.1 TIMING CHART

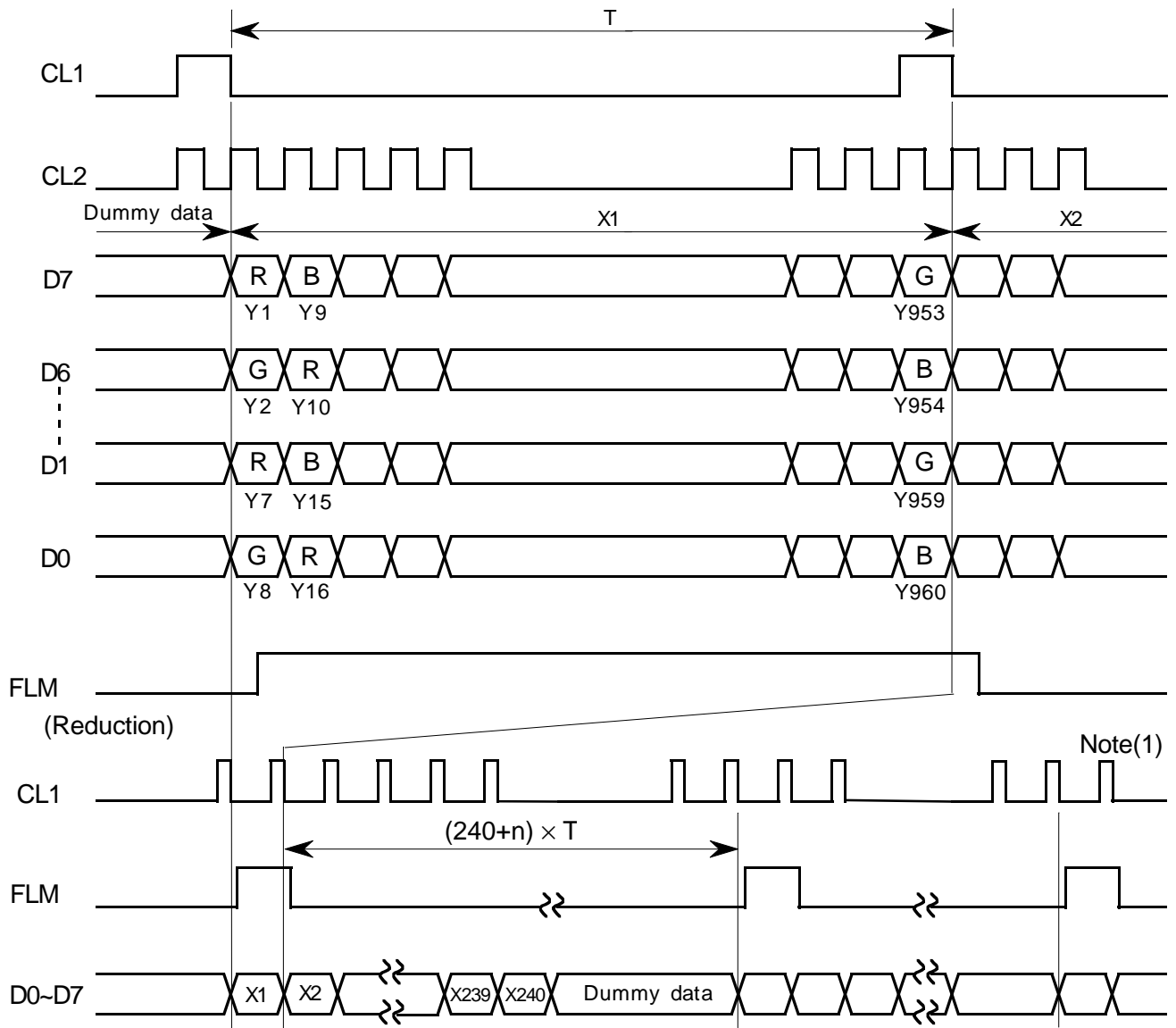

Note(1) The interval of CL1 pulse must be same including the vertical blanking period.

7.2 INTERFACE TIMING SPECIFICATION

VDD=3.3±0.15V, VSS=0V, Vcon=1.0~VDD, Ta=+5°C~+40°C

ITEM	SYMBOL	MIN	TYP	MAX	UNIT
CL1 pulse width "H"	tWHCL1	100	—	—	ns
Clock cycle time	tCYC	60	—	—	ns
CL2 pulse width	tWCL2	30	—	—	ns
Clock set up time	tSCL1	40	—	—	ns
Clock hold time	tHCL1	80	—	—	ns
Clock rise fall time	tr, tf	—	—	30	ns
Data set up time	tDSU	20	—	—	ns
Data hold time	tDH	20	—	—	ns
"FLM" set up time	tFS	100	—	—	ns
"FLM" hold time	tFH	50	—	—	ns

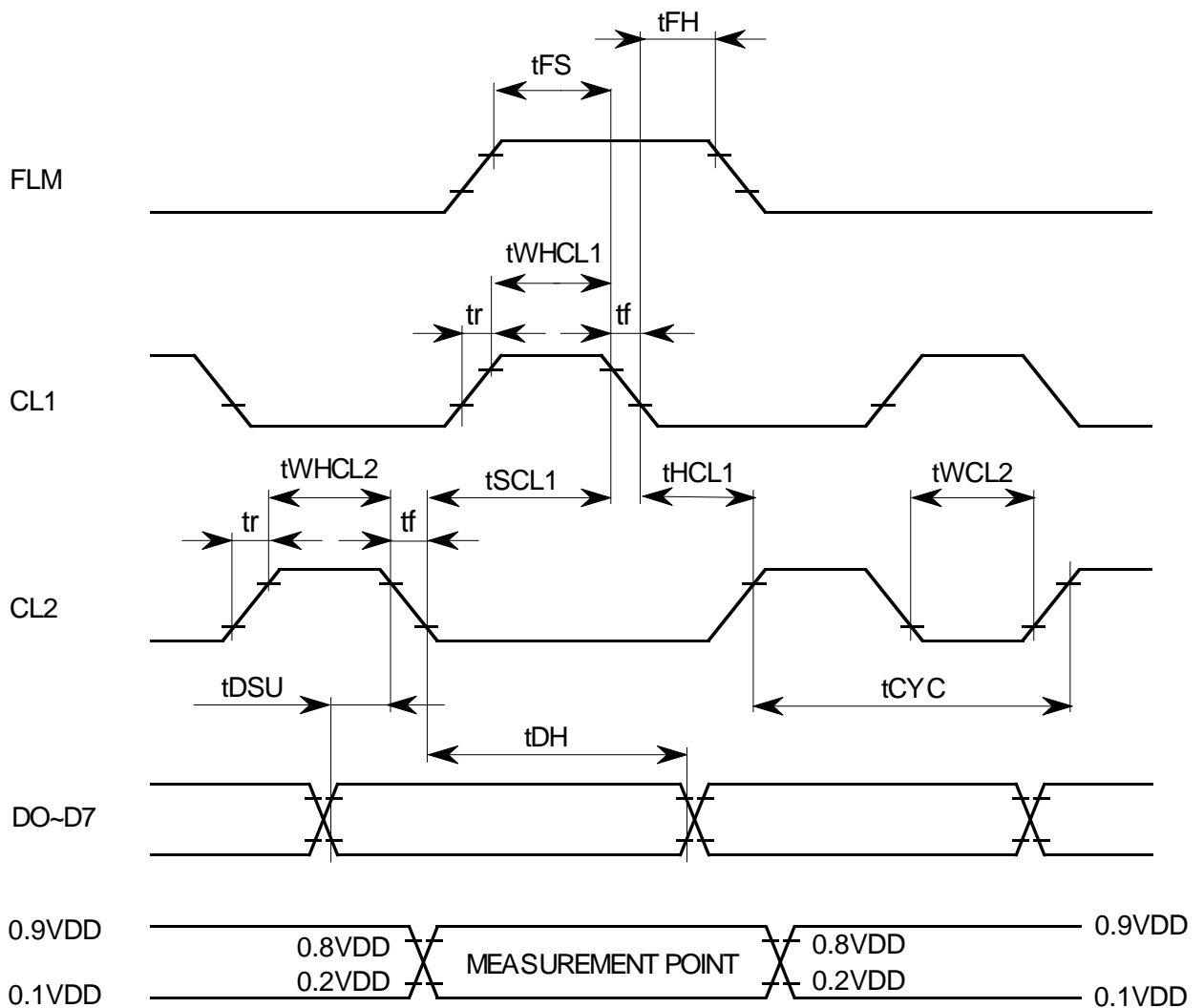

7.3 POWER ON / OFF SEQUENCE

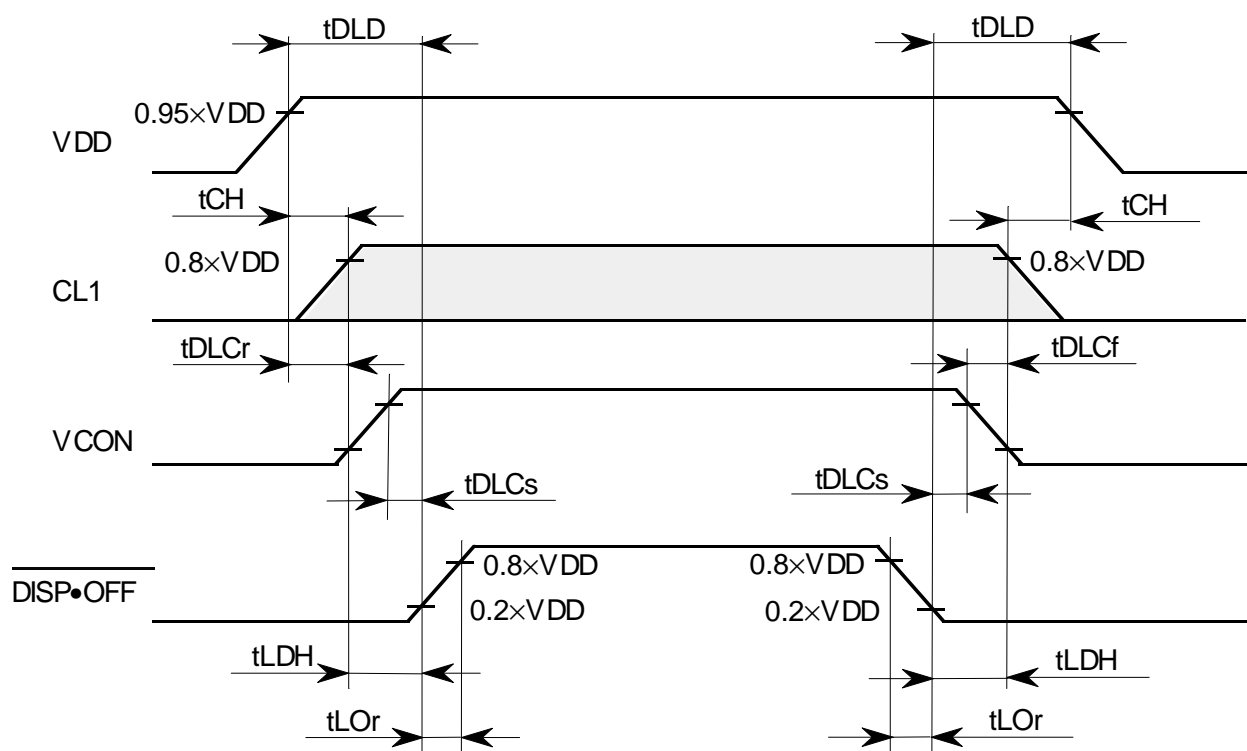

SYMBOL	MIN	MAX	UNIT	COMMENT
tDLD	200		ms	(Note 1)
tCH	0		ms	
tLDH	0		ms	
tDO _r		100	ns	(Note 2)
tDO _f		100	ns	
tDLC _r	0		ms	
tDLC _f	0		ms	
tDLC _s	20		ms	

(Note 1) Please keep the specified sequence because wrong sequence may cause permanent damage to the LCD panel.

(Note 2) Hitachi recommends you to use $\overline{\text{DISP}}\bullet\text{OFF}$ function.
 Display quality may deteriorate if you don't use $\overline{\text{DISP}}\bullet\text{OFF}$ function.

7.4 POWER SUPPLY FOR LCM

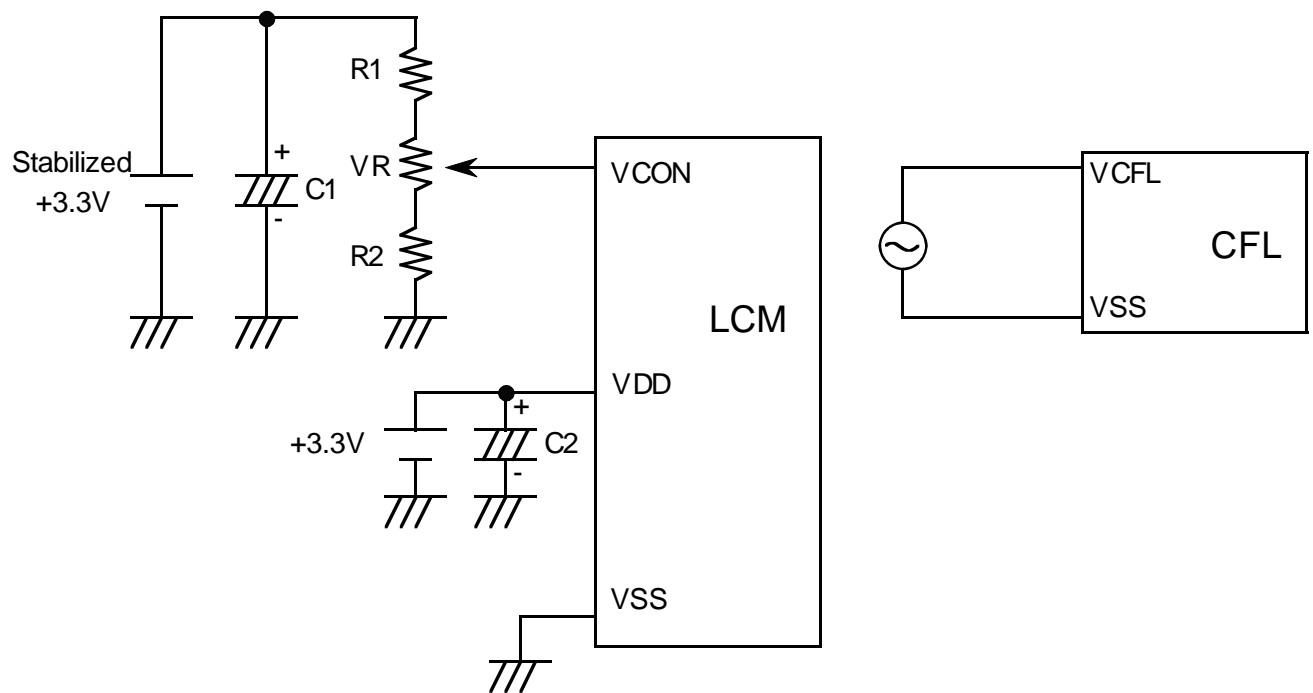

Note 1 : $R1+VR+R2 \leq 10k\Omega$

7.5 INPUT DATA ALLOCATION TABLE

Data Signal	D 7	D 6	D 5	D 4	D 3	D 2	D 1	D 0	D 7	D 6	D 5	D 4	-----	D 4	D 3	D 2	D 1	D 0
Y X	1	2	3	4	5	6	7	8	9	10	11	12	-----	9 5 6	9 5 7	9 5 8	9 5 9	9 6 0
1	R	G	B	R	G	B	R	G	B	R	G	B	-----	G	B	R	G	B
2	R	G	B	R	G	B	R	G	B	R	G	B	-----	G	B	R	G	B
3	R	G	B	R	G	B	R	G	B	R	G	B	-----	G	B	R	G	B
4	R	G	B	R	G	B	R	G	B	R	G	B	-----	G	B	R	G	B
5	R	G	B	R	G	B	R	G	B	R	G	B	-----	G	B	R	G	B
⋮	⋮	⋮	⋮	⋮	⋮	⋮	⋮	⋮	⋮	⋮	⋮	⋮		⋮	⋮	⋮	⋮	⋮
138	R	G	B	R	G	B	R	G	B	R	G	B	-----	G	B	R	G	B
139	R	G	B	R	G	B	R	G	B	R	G	B	-----	G	B	R	G	B
140	R	G	B	R	G	B	R	G	B	R	G	B	-----	G	B	R	G	B
141	R	G	B	R	G	B	R	G	B	R	G	B	-----	G	B	R	G	B
142	R	G	B	R	G	B	R	G	B	R	G	B	-----	G	B	R	G	B
143	R	G	B	R	G	B	R	G	B	R	G	B	-----	G	B	R	G	B
144	R	G	B	R	G	B	R	G	B	R	G	B	-----	G	B	R	G	B
145	R	G	B	R	G	B	R	G	B	R	G	B	-----	G	B	R	G	B
⋮	⋮	⋮	⋮	⋮	⋮	⋮	⋮	⋮	⋮	⋮	⋮	⋮		⋮	⋮	⋮	⋮	⋮
238	R	G	B	R	G	B	R	G	B	R	G	B	-----	G	B	R	G	B
239	R	G	B	R	G	B	R	G	B	R	G	B	-----	G	B	R	G	B
240	R	G	B	R	G	B	R	G	B	R	G	B	-----	G	B	R	G	B

R : RED
 G : GREEN
 B : BLUE

8. INTERNAL PIN CONNECTION

CN1 JAE : FA3S026H5 (Suitable FPC t0.3±0.05mm, 0.5mm pitch)

PIN No.	SIGNAL	LEVEL	FUNCTION
1	N.C	-	Frontlight
2	N.C	-	Frontlight
3	Y1	-	Analog Signal Touch Panel
4	X1	-	Analog Signal Touch Panel
5	Y2	-	Analog Signal Touch Panel
6	X2	-	Analog Signal Touch Panel
7	VSS	-	GND
8	VCON	-	Contrast Adjust
9	VDD	-	Power Supply for Logic
10	$\overline{\text{DISP}}\bullet\text{OFF}$	H / L	H : ON / L : OFF
11	D7	H / L	Display Data
12	D6		
13	D5		
14	D4		
15	VSS	-	GND
16	D3	H / L	Display Data
17	D2		
18	D1		
19	D0		
20	VSS	-	GND
21	VDD	-	Power Supply for Logic
22	CL2	H → L	Data Shift
23	VSS	-	GND
24	CL1	H → L	Data Latch
25	VSS	-	GND
26	FLM	H	First Line Marker

CN3 JST : housing : BHSR-02VS-1 (Suitable Connector : JST SM02B-BHSS-1)
contact pin : SBHS-002T-P0.5

PIN No.	SIGNAL	LEVEL	FUNCTION
1	VCFL	-	Power Supply for CFL
2	VSS	-	GND for CFL