

FEATURES

- **3 V SINGLE SUPPLY VOLTAGE**
- **LOW CURRENT DISSIPATION:** $I_{CC} = 7$ mA TYP
- **HIGH CONVERSION GAIN:** 80 dB TYP
- **OUTPUT LIMITING:** 450 mV p-p
- **WIDE BAND OPERATION UP TO 500 MHz**
- **AGC:** 19 dB Typical

DESCRIPTION AND APPLICATIONS

The UPC2753GR is a frequency converter manufactured with the NESAT III process. This product consists of an RF input amplifier, Gilbert cell mixer, LO input buffer, IF amplifier with AGC, external filter port, and IF output limiting amplifier. This device was specifically designed for low cost GPS receivers, mobile radios, and PCN applications.

NEC's stringent quality assurance and test procedures assure the highest reliability and performance.

INTERNAL BLOCK DIAGRAM

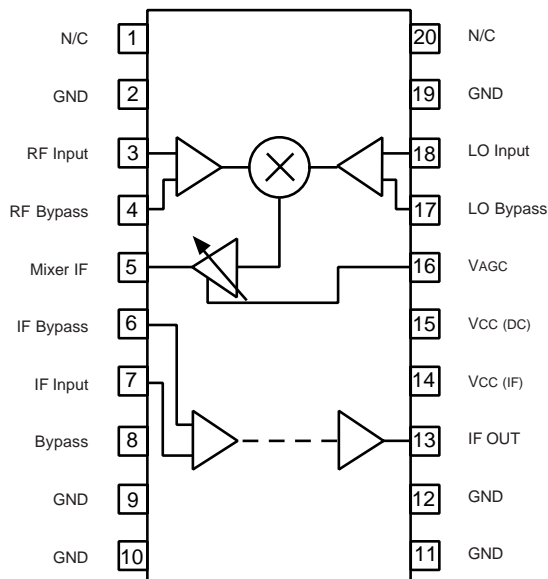

ELECTRICAL CHARACTERISTICS (T_A = 25°C, V_{CC} = 3.0 V, Z_L = Z_S = 50 Ω)

PART NUMBER PACKAGE OUTLINE			UPC2753GR S20			
SYMBOLS	PARAMETERS AND CONDITIONS	UNITS	MIN	TYP	MAX	
Downconverter & AGC Amplifier	I _{CC}	Total Circuit Current ⁴	mA	4.7	6.9	8.5
	RF _u	RF Input Frequency Range (3 dB BW) ¹ f _{IF} = 4 MHz, V _{AGC} = GND	MHz			400
	IF _u	IF Output Frequency Range (3dB BW) f _{RF} = 200 MHz, V _{AGC} = GND	MHz			20
	CG	Conversion Gain ² f _{RF} = 200 MHz, f _{IF} = 4 MHz, V _{AGC} = GND	dB	35	38	42
	NF	Noise Figure ² f _{RF} = 200 MHz, f _{IF} = 20 MHz, V _{AGC} = GND	dB		12	15
	RL _{IN}	Input Return Loss f _{RF} ≤ 400 MHz	dB		14	
	ISOL(LO-RF)	LO to RF Isolation ³ , f _{LO} = 1 to 400 MHz	dBc		-52	
	ISOL(LO-IF)	LO to IF Isolation ³ , f _{LO} = 1 to 400 MHz	dBc		-15	
	GCR	Gain Control f _{RF} = 200 MHz, f _{IF} = 4 MHz, V _{AGC} = 1.2 - 2.4 V	dB	15	19	
IF Amplifier	f _u	IF Amplifier Frequency Range ¹ (3 dB BW) (The gain is -3 dB down from the gain at 4 MHz)	MHz	DC		20
	GS _{IF}	IF Amplifier Small Signal Gain f = 4 MHz	dB	38	41	45
	V _{OUT}	Output Voltage (Z _L = 2 KΩ // 2 pF)	mV p-p	350	450	550

Notes:

1. Conversion Gain is -3 dB from Conversion Gain For f_{RF} = 50 MHz.
2. Downconverter and AGC amplifier only.
3. P_{LO} = -10 dBm.
4. Downconverter and IF amp may be operated separately. Typical I_{CC} for down converter is 5.5 mA (pin 15). Typical I_{CC} for IF amp is 1.4 mA (pin 14).

ABSOLUTE MAXIMUM RATINGS¹ (T_A = 25°C)

SYMBOLS	PARAMETERS	UNITS	RATINGS
V _{CC}	Supply Voltage	V	4.0
P _T	Power Dissipation	mW	433
I _{CC}	Total Supply Current	mA	20
T _{OP}	Operating Temperature	°C	-40 to +85
T _{STG}	Storage Temperature	°C	-65 to +150

Note:

1. Operation in excess of any one of these parameters may result in permanent damage.
2. Mounted on a 50 x 50 x 1.6 mm epoxy glass PWB (T_A = 85°C).

RECOMMENDED OPERATING CONDITIONS

SYMBOLS	PARAMETERS	UNITS	MIN	TYP	MAX
V _{CC}	Supply Voltage	V	2.7	3.0	3.3
T _{OP}	Operating Temperature	°C	-40	25	85

PIN FUNCTIONS

Pin No.	Symbol	Pin Voltage	Description	Equivalent Circuit
3	RF Input	2.5	Pin 3 is the input pin of the RF amplifier. Pin 4 should be connected to GND via a bypass capacitor.	
4	RF Bypass	2.5		
5	Mixer IF	1.1	Pin 5 is the output pin of the Mixer IF. The output signal comes from the mixer unit via the AGC amplifier. This output pin features low impedance because it is the output of an emitter-follower.	
6	IF Bypass	2.1	Pins 6 and 7 are the input pins to the IF amplifier. These two inputs are internally connected to the base of each pair of transistors in the differential amplifier. Pin 6 should be connected to GND via a bypass capacitor.	
7	IF Input	2.1		
8	Bypass	2.1	Pin 8 is connected to the feedback loop of the IF amplifier. This pin should be connected to GND via a bypass capacitor to stabilize the DC bias.	
13	IF Out	1.4	Pin 13 is the output pin of the IF amplifier. This output pin features low impedance because it is the output of an emitter-follower.	

PIN FUNCTIONS

Pin No.	Symbol	Pin Voltage	Description	Equivalent Circuit
16	V _{AGC}	0 to 2.4 (Supply voltage)	Pin 16 is the gain control pin for the AGC amplifier. The gain of the AGC amplifier is controlled by the applied voltage on this pin.	
17	LO Bypass	2.5	Pins 17 and 18 are the LO input pins of the mixer. The LO Bypass pin should be connected to GND via a bypass capacitor.	
18	LO Input	2.5		
15	V _{CC} (DC)	—	Pin 15 is the V _{CC} supply pin for the downconverter block. This pin is independent of the V _{CC} pin for the IF amplifier. Apply 3 V to pin 15.	—
14	V _{CC} (IF)	—	Pin 14 is the V _{CC} supply pin for the IF amplifier. This pin is independent of the V _{CC} pin for the downconverter unit. Apply 3 V to pin 16.	—
2 9 12 19	GND	—	This pin is the ground pin for the entire chip. Therefore the ground of the IF downconverter and IF amplifier blocks are not separated. The ground pattern to be connected to this pin should be formed as wide as possible to minimize its impedance.	—
10 11	GND	—	Pins 10 and 11 are not connected to the internal circuits. Connecting these pins to GND is recommended, though these pins may be left unconnected.	—
1	NC	—	Pins 1 and 20 are the output pins of the mixer block. These pins are used to monitor the signal output from the IF amplifier and to be input to the AGC amplifier. When the IC is actually used, these pins should be left opened.	—
20	NC			

TYPICAL PERFORMANCE CURVES ($T_A = 25^\circ\text{C}$, $V_{CC} = 3.0\text{ V}$, $Z_L = Z_S = 50\ \Omega$, $P_{LO} = -10\text{ dBm}$, $V_{AGC} = 0\text{ V}$, $P_{RF} = -70\text{ dBm}$, unless otherwise specified.)

CONVERSION GAIN vs. RF FREQUENCY

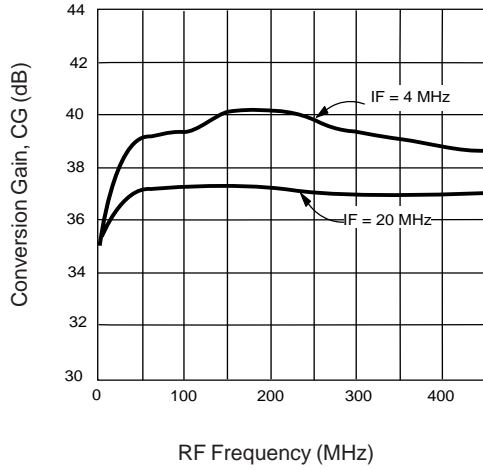

CONVERSION GAIN vs. RF FREQUENCY and LO POWER

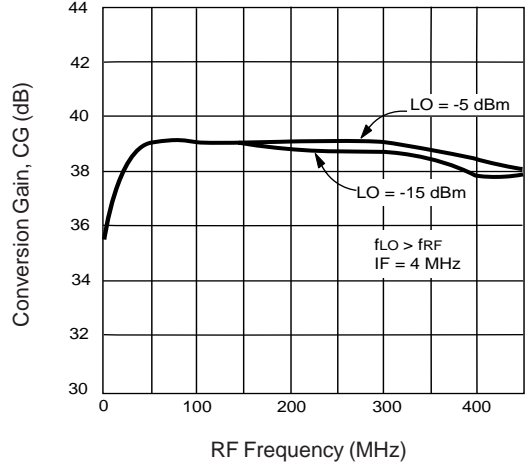

CONVERSION GAIN vs. RF FREQUENCY and V_{CC}

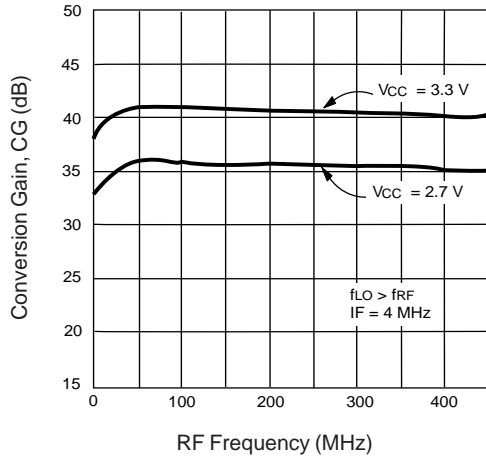

CONVERSION GAIN vs. V_{AGC}

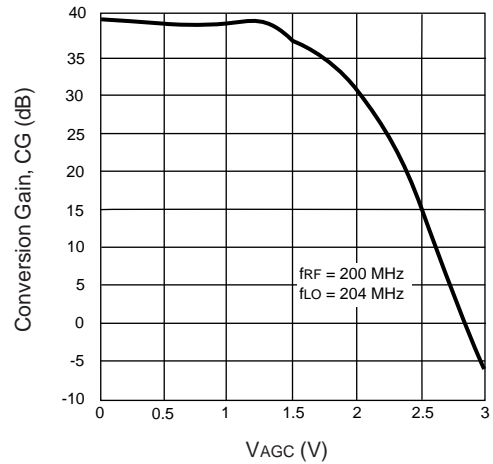

NOISE FIGURE vs. RF FREQUENCY

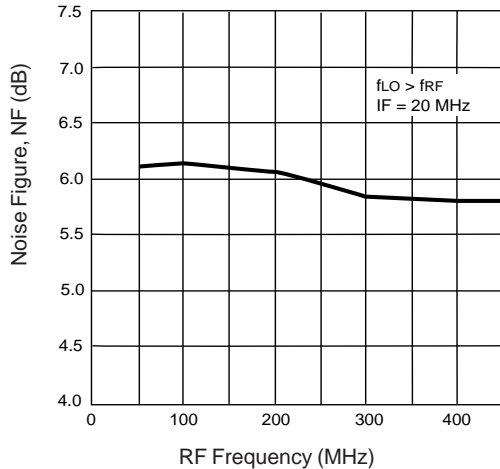

NOISE FIGURE vs. V_{AGC}

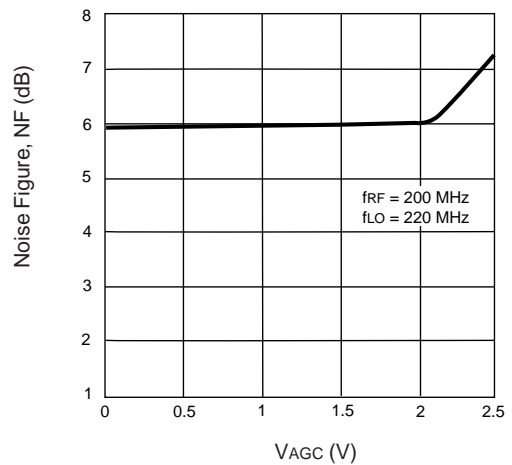

TYPICAL PERFORMANCE CURVES ($T_A = 25^\circ\text{C}$, $V_{CC} = 3.0\text{ V}$, $Z_L = Z_S = 50\ \Omega$, $P_{LO} = -10\text{ dBm}$, $V_{AGC} = 0\text{ V}$, $P_{RF} = -70\text{ dBm}$, unless otherwise specified.)

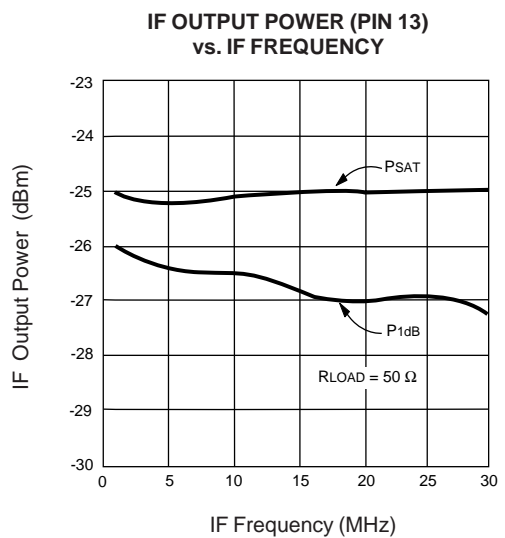
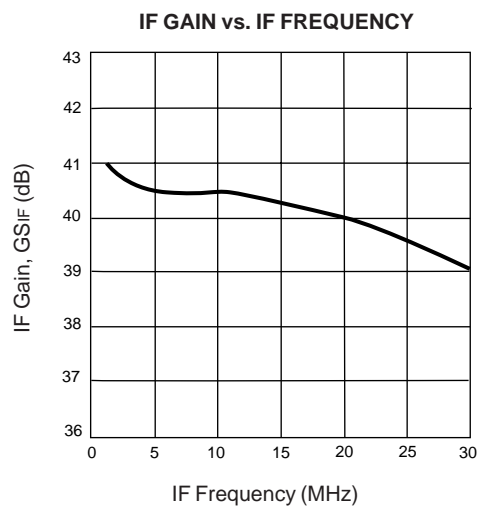
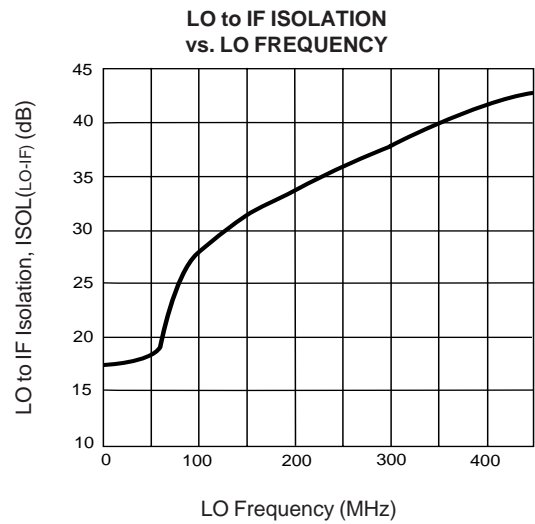
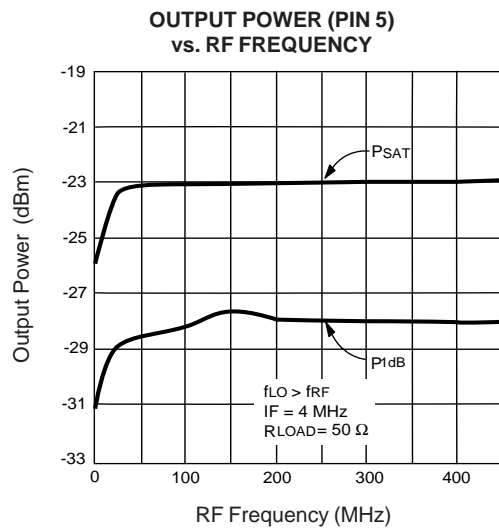

APPLICATION CIRCUIT

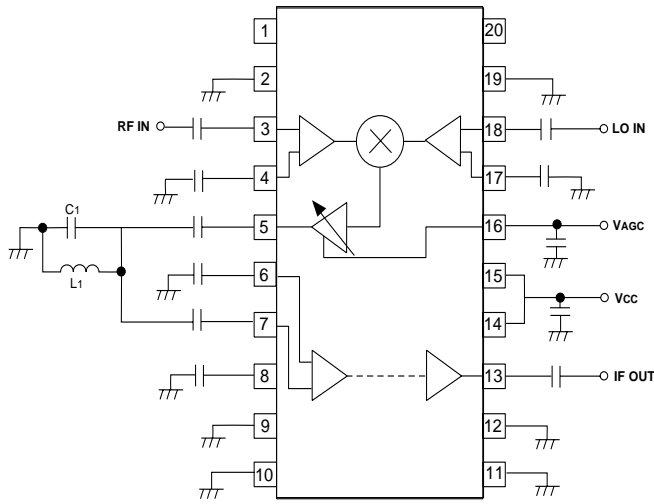

- | | |
|--------------|---------------|
| 1. N/C | 20. N/C |
| 2. GND | 19. GND |
| 3. RF Input | 18. LO Input |
| 4. RF Bypass | 17. LO Bypass |
| 5. Mixer IF | 16. VAGC |
| 6. IF Bypass | 15. VCC (DC) |
| 7. IF Input | 14. VCC (IF) |
| 8. Bypass | 13. IF OUT |
| 9. GND | 12. GND |
| 10. GND | 11. GND |

Notes:

- All unmarked caps are 1000 pF.
- Bandpass filter element values chosen by equation:
 $f_{IF} = 1/2\pi \sqrt{L_1 C_1}$; e.g., $L_1 = 3.3 \mu H$, $C_1 = 68 pF$ for $f_{IF} = 10 MHz$.

OUTLINE DIMENSIONS (Units in mm)

PACKAGE OUTLINE SSOP 20

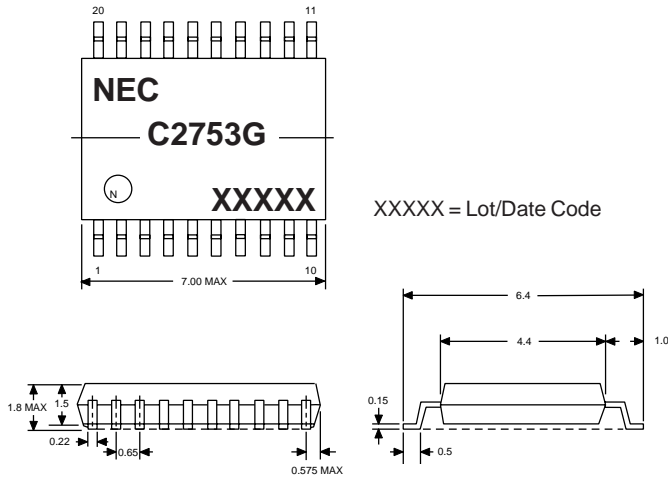

Lead Material: Alloy 42
 Lead Plating: Lead Tin Alloy

LEAD CONNECTIONS:

- | | |
|--------------|---------------|
| 1. N/C | 11. GND |
| 2. GND | 12. GND |
| 3. RF Input | 13. IF OUT |
| 4. RF Bypass | 14. VCC (IF) |
| 5. Mixer IF | 15. VCC (DC) |
| 6. IF Bypass | 16. VAGC |
| 7. IF Input | 17. LO Bypass |
| 8. Bypass | 18. LO Input |
| 9. GND | 19. GND |
| 10. GND | 20. N/C |

RF INPUT MATCH (S11)

PINS 3, 4, 17, and 18

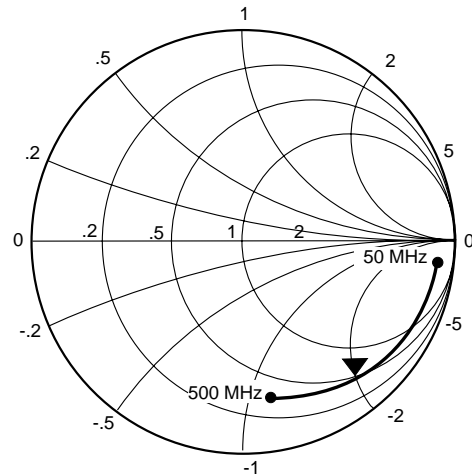

Marker: 315.5 MHz Start 50 MHz Stop 500 MHz
 $\Gamma_x = .53$
 $\Gamma_y = -.67$
 $R = 20.1 \Omega$
 $X = -100.6 \Omega$
 $L_s = -50.7 nH$
 $C_s = 5.0 pF$

ORDERING INFORMATION

PART NUMBER	QUANTITY
UPC2753GR-E1	2500/Reel

EXCLUSIVE NORTH AMERICAN AGENT FOR **NEC** RF, MICROWAVE & OPTOELECTRONIC SEMICONDUCTORS

CEL CALIFORNIA EASTERN LABORATORIES • Headquarters • 4590 Patrick Henry Drive • Santa Clara, CA 95054-1817 • (408) 988-3500 • Telex 34-6393 • FAX (408) 988-0279

24-Hour Fax-On-Demand: 800-390-3232 (U.S. and Canada only) • Internet: <http://WWW.CEL.COM>

DATA SUBJECT TO CHANGE WITHOUT NOTICE

PRINTED IN USA ON RECYCLED PAPER -11/97