

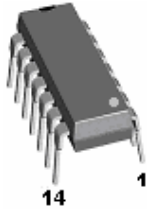

# TS324

## Quad Operating Amplifier

DIP-14



SOP-14

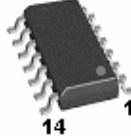

Pin assignment:

- |                |                 |
|----------------|-----------------|
| 1. Output A    | 14. Output D    |
| 2. Input A (-) | 13. Input D (-) |
| 3. Input A (+) | 12. Input D (+) |
| 4. Vcc         | 11. Gnd         |
| 5. Input B (+) | 10. Input C (+) |
| 6. Input B (-) | 9. Input C (-)  |
| 7. Output B    | 8. Output C     |

**Supply Voltage Range 3 V to 32V**  
**Quad Channel Amplifier**

### General Description

The TS324 contains four independent high gain operational amplifiers with internal frequency compensation. The four op-amps use a split power supply. The device has low power supply current drain, regardless of the power supply voltage. The low power drain also makes the TS324 a good choice for battery operation.

When your project calls for a traditional op-amp function, now you can streamline your design with a simple single power supply. Use ordinary +5V common to practically any digital system or personal computer application, without requiring an extra 15V power supply just to have the interface electronics you need.

The TS324 is a versatile, rugged workhorse with a thousand-and-one uses, from amplifying signals from a variety of transducers to dc gain blocks, or any op-amp function. The attached pages offer some recipes that will have your project cooking in no time.

The TS358 is offered in 14 pin SOP-14 and DIP-14 package.

### Features

- ◇ Single supply operation: 3V to 32V
- ◇ Low input bias currents
- ◇ Internally compensated
- ◇ Common mode range extends to negative supply
- ◇ Single and split supply operation

### Block Diagram

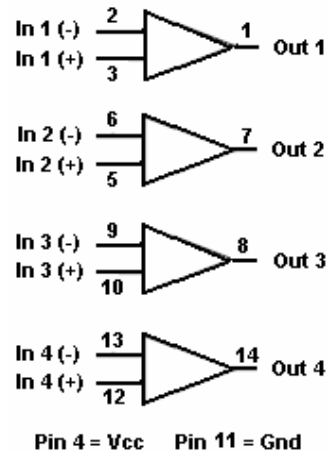

### Ordering Information

Part No.	Operating Temp.	Package
TS324CD	0 ~ +70 °C	DIP-14
TS324CS		SOP-14

### Absolute Maximum Rating

Supply Voltage	Vcc, Vcc/Vee	+32 or ±16	Vdc
Differential Input Voltage (note 1)	V <sub>IDR</sub>	32	Vdc
Input Common Mode Voltage Range (note 2)	V <sub>ICR</sub>	-0.3 to 32	Vdc
Input Forward Current (note 3)	I <sub>IF</sub>	50	mA
Output Short Circuit Duration	I <sub>SC</sub>	Continuous	mA
Operating Junction Temperature Range	T <sub>J</sub>	0 ~ +125	°C
Storage Temperature Range	T <sub>STG</sub>	-65 ~ +150	°C

NOTE :

1. Split Power Supplies.
2. For supply. Voltages less than 32V for the PJ324 the absolute maximum input voltage is equal to the supply voltage.
3. This input current will only exist when the voltage is negative at any of the input leads. Normal output states will reestablish when the input voltage returns to a voltage greater than -0.3V.



## Electrical Characteristics

( $V_{CC} = 5V$ ,  $T_a = 25^\circ C$ ; unless otherwise specified.)

Characteristics	Symbol	Min	Typ	Max	Unit
Input Offset Voltage $V_{CC} = 5.0V$ to $30V$ , $V_{IC} = 0V$ to $V_{CC} - 1.7V$ , $V_O = 1.4V$ , $R_S = 0\Omega$ $T_{LOW} \leq T_a \leq T_{HIGH}$	$V_{io}$	--	2.0	7.0	mV
Average Temperature Coefficient of Input Offset Voltage	$\Delta I_{io}/\Delta T$	--	7.0	--	$\mu V/^\circ C$
Input Offset Current $T_{LOW} \leq T_a \leq T_{HIGH}$	$I_{io}$	--	5.0	50	nA
Average Temperature Coefficient of input Offset Current	$\Delta I_{io}/\Delta T$	--	10	--	$\mu A/^\circ C$
Input Bias Current $T_{LOW} \leq T_a \leq T_{HIGH}$	$I_{IB}$	--	45	-250	$\mu A$
Input Common-Mode Voltage Range (Note1) $V_{CC} = 30V$ $V_{CC} = 30V$ , $T_{LOW} \leq T_a \leq T_{HIGH}$	$V_{ICR}$	0	--	28.3	V
Differential Input Voltage Range	$V_{IDR}$	--	--	$V_{CC}$	V
Large Signal Open-Loop Voltage Gain $R_L = 2.0K$ , $V_{CC} = 15V$ , For Large $V_O$ Swing, $T_{LOW} \leq T_a \leq T_{HIGH}$	$A_{VOL}$	25	100	--	V/mV
Channel Separation 1.0 KHz to 20KHz	--	--	-120	--	dB
Common Mode Rejection Ratio $R_S \leq 10k\Omega$	CMRR	65	70	--	dB
Power Supply Rejection Ratio	PSRR	65	100	--	dB
Output Voltage -- High Limit $V_{CC} = 30V$ , $R_L = 2k\Omega$ $V_{CC} = 30V$ , $R_L = 10k\Omega$	$V_{OH}$	26	--	--	V
Output Voltage -- Low Limit $V_{CC} = 5.0V$ , $R_L = 10k\Omega$	$V_{OL}$	--	5.0	20	mV
Output Source Current $V_{ID} = +1.0V$ , $V_{CC} = 15V$	$I_{O+}$	20	40	--	mA
Output Sink Current $V_{ID} = -1.0V$ , $V_{CC} = 15V$ $V_{ID} = -1.0V$ , $V_O = 200mV$	$I_{O-}$	10	20	--	mA
Output Short Circuit to Ground (Note 2)	$I_{OS}$	--	40	60	mA
Power Supply Current , $V_{CC} = 30V$ , $V_O = 0V$ , $R_L = \infty$ $V_{CC} = 5.0V$ , $V_O = 0V$ , $R_L = \infty$	$I_{CC}$	--	1.5	3.0	mA
<b>Notes :</b>					
1. The input common mode voltage or either input signal voltage should not be allowed to go negative by more than 0.3 V. The upper end of the common mode voltage range is $V_{CC} 17V$ , but either or both inputs can go to $+32V$ .					
2. Short circuits from the output to $V_{CC}$ can cause excessive heating and eventual destruction. Destructive dissipation can recruit from simultaneous shorts on all amplifiers.					



## Circuit Description

The TS324 made using four internally compensated, two-stage operational amplifiers. The first stage performs not only the first stage gain function but also performs the level shifting and transconductance reduction functions. By reducing the transconductance, a smaller compensation capacitor (only 5.0pF) can be employed, thus saving chip area. Another feature of this input stage is that the input common mode range can include the negative supply or ground, in single supply operation, without saturating either the input devices or the differential to single-ended converter. The second stage consists of a standard current source load amplifier stage.

Each amplifier is biased from an internal-voltage regulator, and which has a low temperature coefficient thus giving each amplifier good temperature characteristics as well as excellent power supply rejection.

## Electrical Characteristics Curve

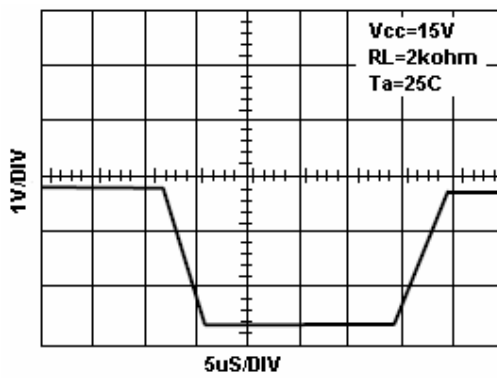

Figure 1. large signal voltage follower response

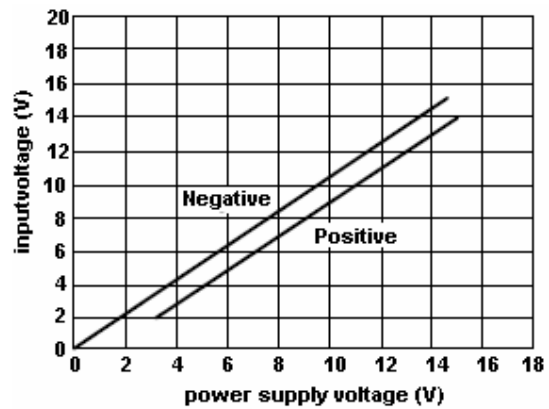

Figure 2. input voltage range

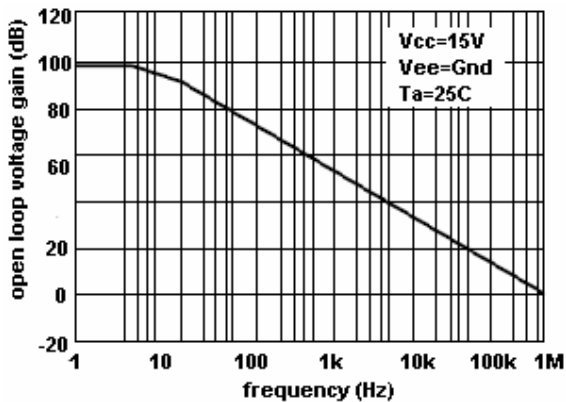

Figure 3. large signal open loop voltage gain

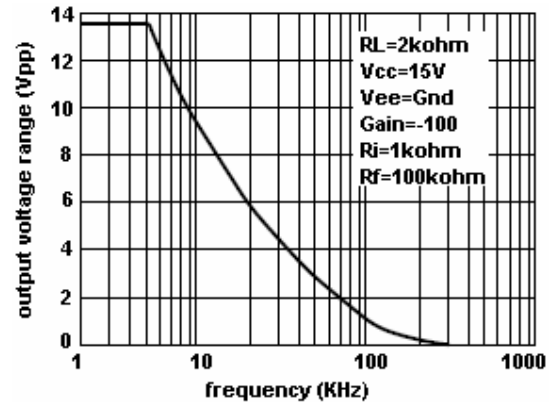

Figure 4. larger signal frequency response

## Circuit Description

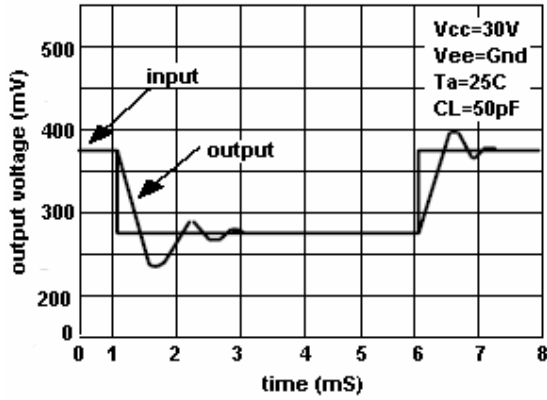

Figure 5. small signal voltage follower pulse response (noninverting)

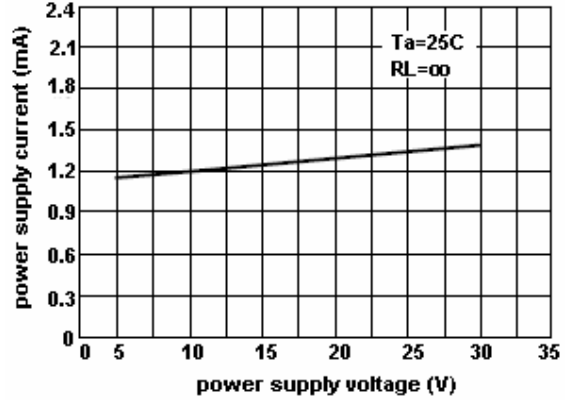

Figure 6. power supply current vs supply voltage

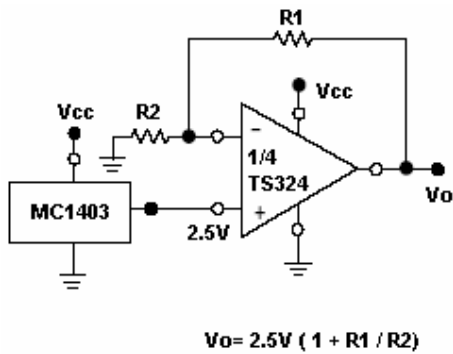

Figure 7. voltage reference

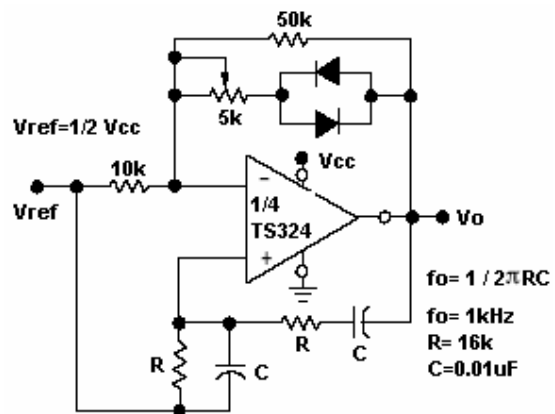

Figure 8. wien bridge oscillator

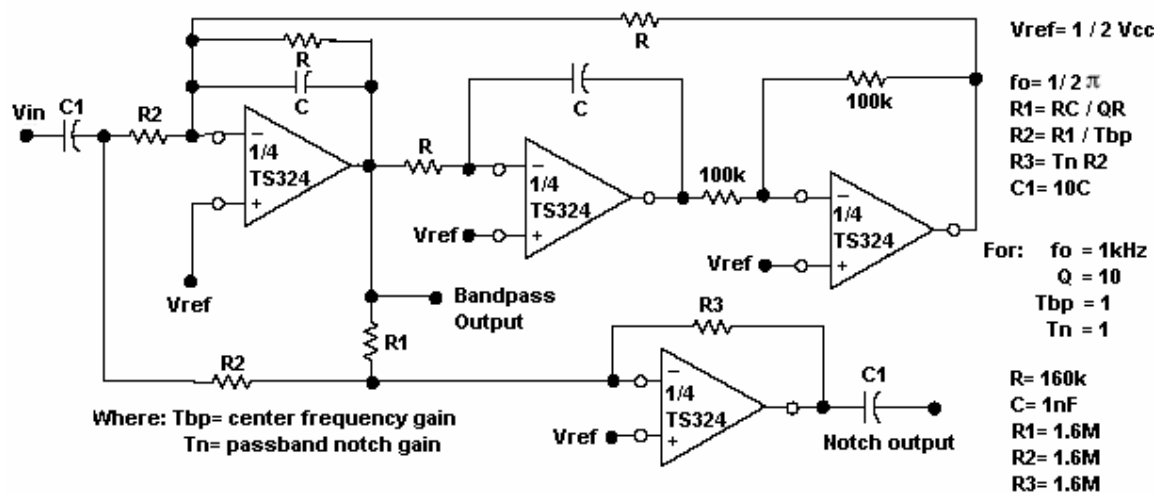

Figure 9. bi-quad filter

### Circuit Description (continued)

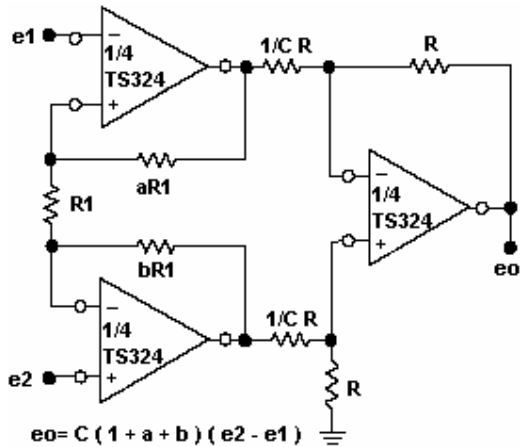
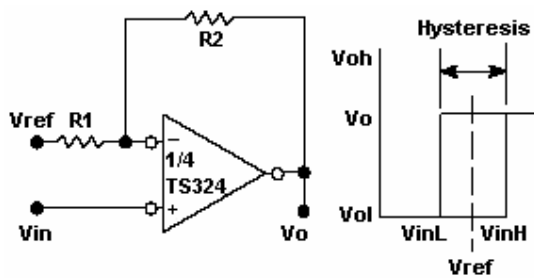

Figure 10. high impedance differential amplifier



$$V_{inL} = R1 / (R1 + R2) * (V_{ol} - V_{ref}) + V_{ref}$$

$$V_{inH} = R1 / (R1 + R2) * (V_{oh} - V_{ref}) + V_{ref}$$

$$H = R1 / (R1 + R2) * (V_{oh} - V_{ol})$$

Figure 11. comparator with hysteresis

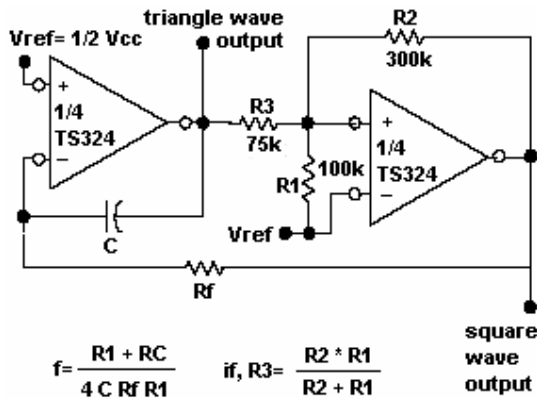

$$f = \frac{R1 + RC}{4 C Rf R1} \quad \text{if, } R3 = \frac{R2 * R1}{R2 + R1}$$

Figure 12. function generator

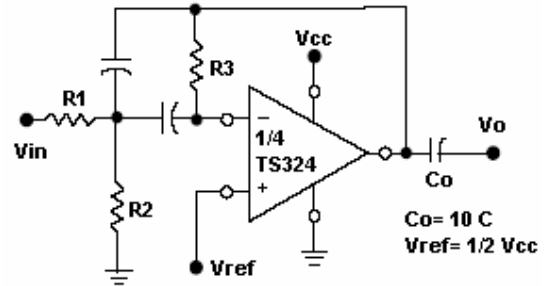

Given:  $f_o$  = center frequency  
 $A(f_o)$  = gain at center frequency

Choose value  $f_o, C$   
 Then:  $R3 = Q / \pi f_o C$   
 $R1 = R3 / 2A(f_o)$   
 $R2 = R1 * R3 / 4Q^2 * R1 - R3$

For less than 10% error from operational amplifier,  
 $Qo f_o / BW < 0.1$   
 Where  $f_o$  and  $BW$  are expressed in Hz

If source impedance varies, filter may be preceded with Voltage follower buffer stabilize filter parameters

Figure 13. multiple feedback bandpass filter

## SOP-14 Mechanical Drawing

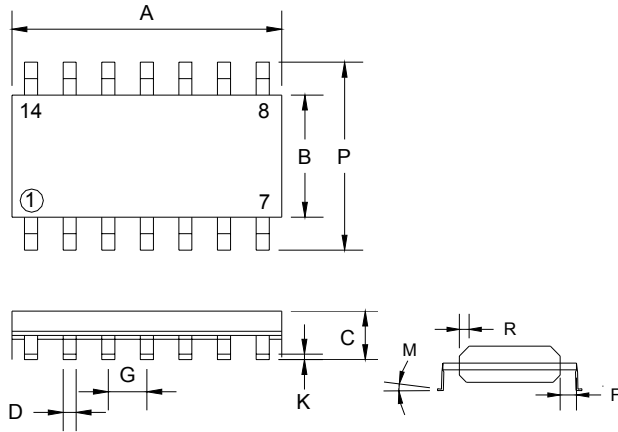

SOP-14 DIMENSION				
DIM	MILLIMETERS		INCHES	
	MIN	MAX	MIN	MAX
A	8.55	8.75	0.337	0.344
B	3.80	4.00	0.150	0.157
C	1.35	1.75	0.054	0.068
D	0.35	0.49	0.014	0.019
F	0.40	1.25	0.016	0.049
G	1.27 (typ)		0.05 (typ)	
K	0.10	0.25	0.004	0.009
M	0°	7°	0°	7°
P	5.80	6.20	0.229	0.244
R	0.25	0.50	0.010	0.019

## DIP-14 Mechanical Drawing

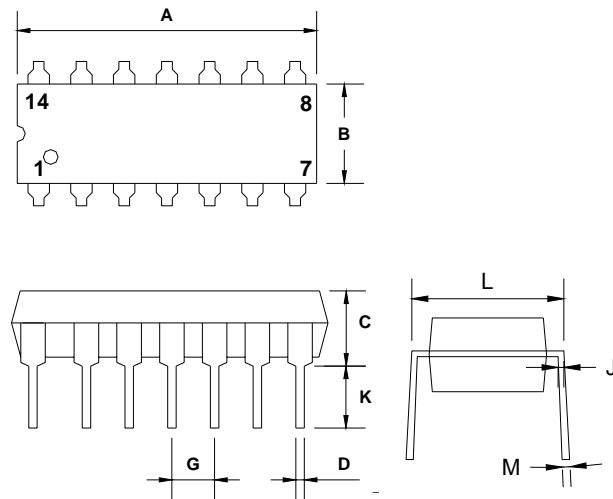

DIP-14 DIMENSION				
DIM	MILLIMETERS		INCHES	
	MIN	MAX	MIN	MAX
A	18.55	19.56	0.730	0.770
B	6.22	6.48	0.245	0.255
C	3.18	4.45	0.125	0.135
D	0.35	0.55	0.019	0.020
G	2.54 (typ)		0.10 (typ)	
J	0.29	0.31	0.011	0.012
K	3.25	3.35	0.128	0.132
L	7.75	8.00	0.305	0.315
M	-	10°	-	10°