

TOSHIBA CMOS DIGITAL INTEGRATED CIRCUIT SILICON MONOLITHIC

TC7MH165FK

8 - Bit Shift Register (P - In, S - Out)

The TC7MH165 is an advanced high speed CMOS 8-BIT PARALLEL/SERIAL-IN, SERIAL-OUT SHIFT REGISTER fabricated with silicon gate C²MOS technology.

It achieves the high speed operation similar to equivalent Bipolar Schottky TTL while maintaining the CMOS low power dissipation.

It consists of parallel-in or serial-in, serial-out 8 - bit shift register with a gated clock input. When the SHIFT/LOAD input is held high, the serial data input is enabled and the eight flip-flops perform serial shifting with each clock pulse.

When the SHIFT/LOAD input is held low, the parallel data is loaded synchronously into the register at positive going transition of the clock pulse.

The CK-INH input should be shifted high only when the CK input is held high.

An Input protection circuit ensures that 0 to 7V can be applied to the input pins without regard to the supply voltage. This device can be used to interface 5V to 3V systems and on two supply systems such as battery back up. This circuit prevents device destruction due to mismatched supply and input voltages.

Features:

- High Speed $f_{MAX} = 150\text{MHz}(\text{typ.})$ at $V_{CC} = 5\text{V}$
- Low Power Dissipation $I_{CC} = 4\mu\text{A}(\text{max})$ at $T_a = 25^\circ\text{C}$
- High Noise Immunity..... $V_{NIH} = V_{NIL} = 28\% V_{CC} (\text{min})$
- Power Down Protection is provided on all inputs.
- Balanced Propagation Delays..... $t_{pLH} \approx t_{pHL}$
- Wide Operating Voltage Range... $V_{CC} (\text{opr}) = 2\text{V} \sim 5.5\text{V}$
- Pin and Function Compatible with 74ALS165

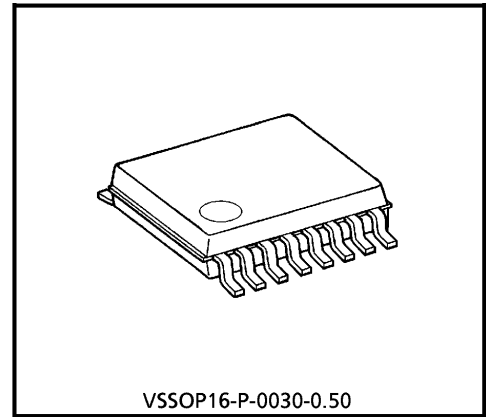

VSSOP16-P-0030-0.50

Weight: 0.02g (Typ.)

Pin Assignment

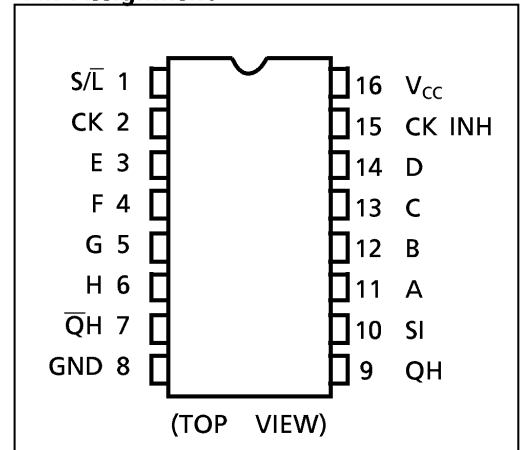

IEC Logic Symbol

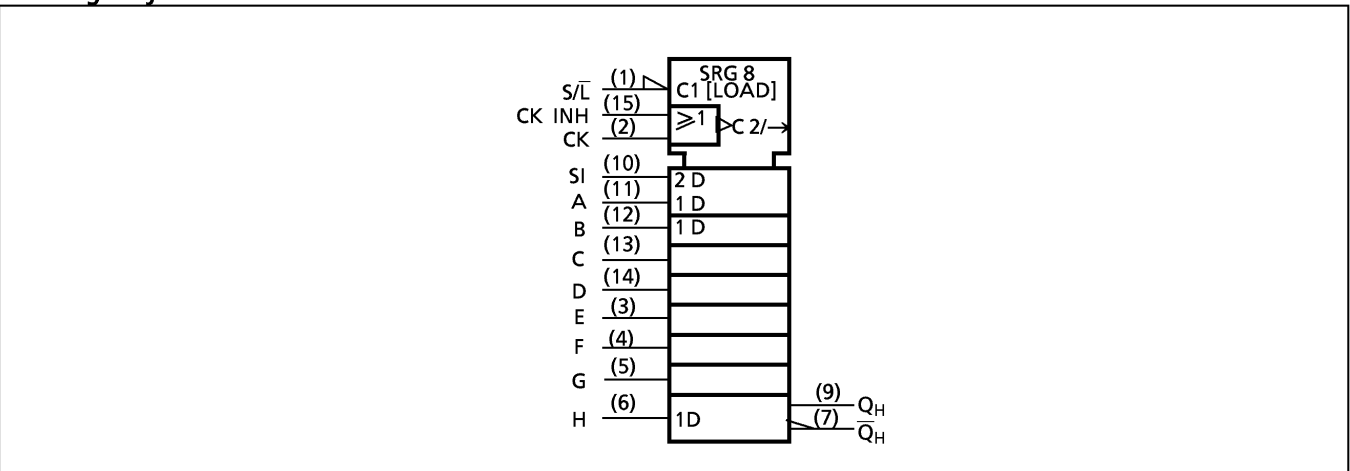

980910EBA2

● TOSHIBA is continually working to improve the quality and the reliability of its products. Nevertheless, semiconductor devices in general can malfunction or fail due to their inherent electrical sensitivity and vulnerability to physical stress. It is the responsibility of the buyer, when utilizing TOSHIBA products, to observe standards of safety, and to avoid situations in which a malfunction or failure of a TOSHIBA product could cause loss of human life, bodily injury or damage to property. In developing your designs, please ensure that TOSHIBA products are used within specified operating ranges as set forth in the most recent products specifications. Also, please keep in mind the precautions and conditions set forth in the TOSHIBA Semiconductor Reliability Handbook.

Truth Table

INPUTS					INTERNAL OUTPUTS		OUTPUT	
SHIFT/LOAD	CLOCK INH	CLOCK	SERIAL IN	PARALLEL A H	QA	QB	QH	$\bar{Q}H$
L	X	X	X	a h	a	b	h	\bar{h}
H	L	\downarrow	H	X	H	QAn	QGn	$\bar{Q}Gn$
H	L	\downarrow	L	X	L	QAn	QGn	$\bar{Q}Gn$
H	\downarrow	L	H	X	H	QAn	QGn	$\bar{Q}Gn$
H	\downarrow	L	L	X	L	QAn	QGn	$\bar{Q}Gn$
H	X	H	X	X	NO CHANGE			
H	H	X	X	X	NO CHANGE			

X : Don't Care
 a h : The level of steady state input voltage at inputs A through H respectively
 QAn~QGn: The level of QA~QG, respectively, before the most recent positive transition of the CK.

Timing Chart

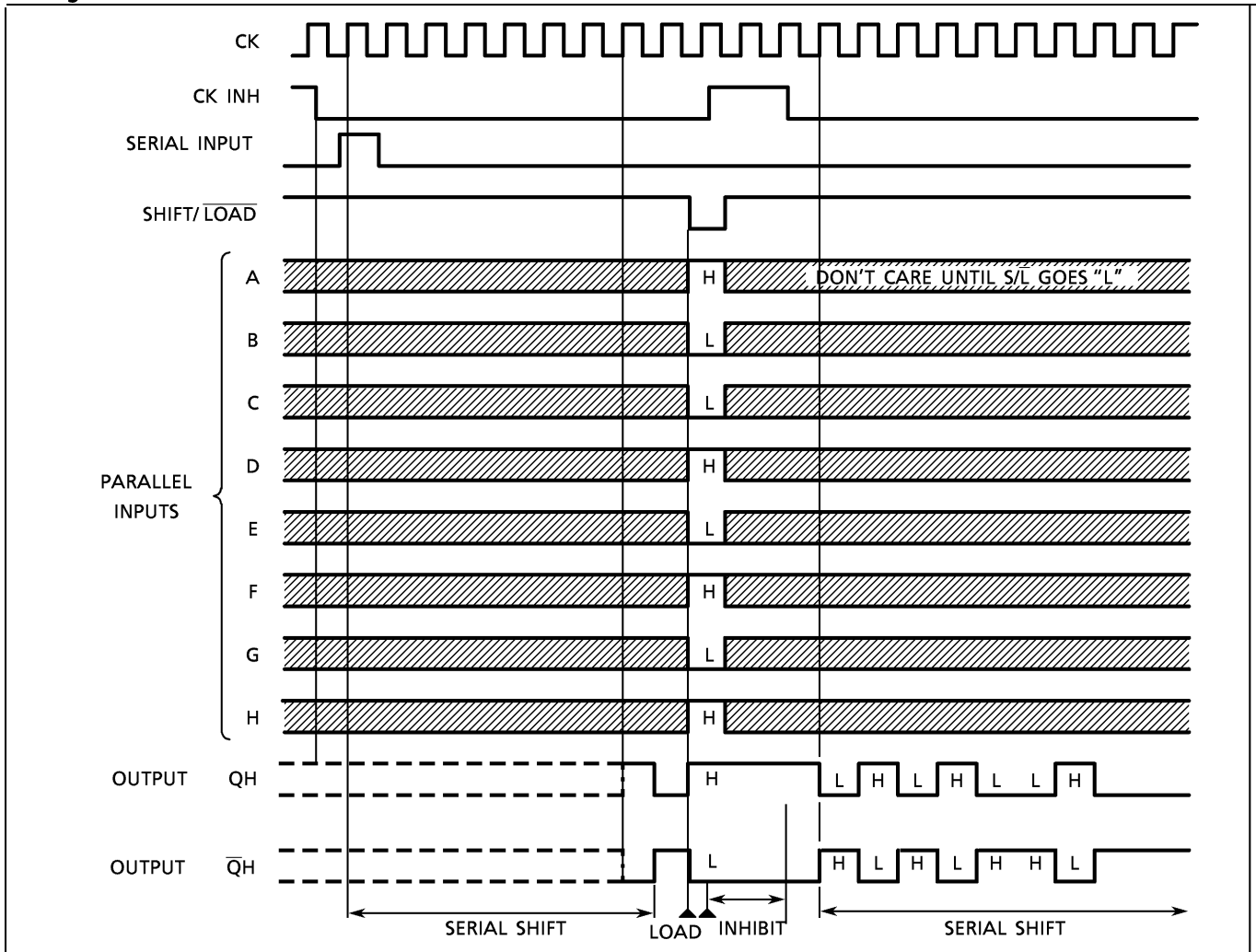

980910EBA2'

- The products described in this document are subject to the foreign exchange and foreign trade laws.
- The information contained herein is presented only as a guide for the applications of our products. No responsibility is assumed by TOSHIBA CORPORATION for any infringements of intellectual property or other rights of the third parties which may result from its use. No license is granted by implication or otherwise under any intellectual property or other rights of TOSHIBA CORPORATION or others.
- The information contained herein is subject to change without notice.

System Diagram

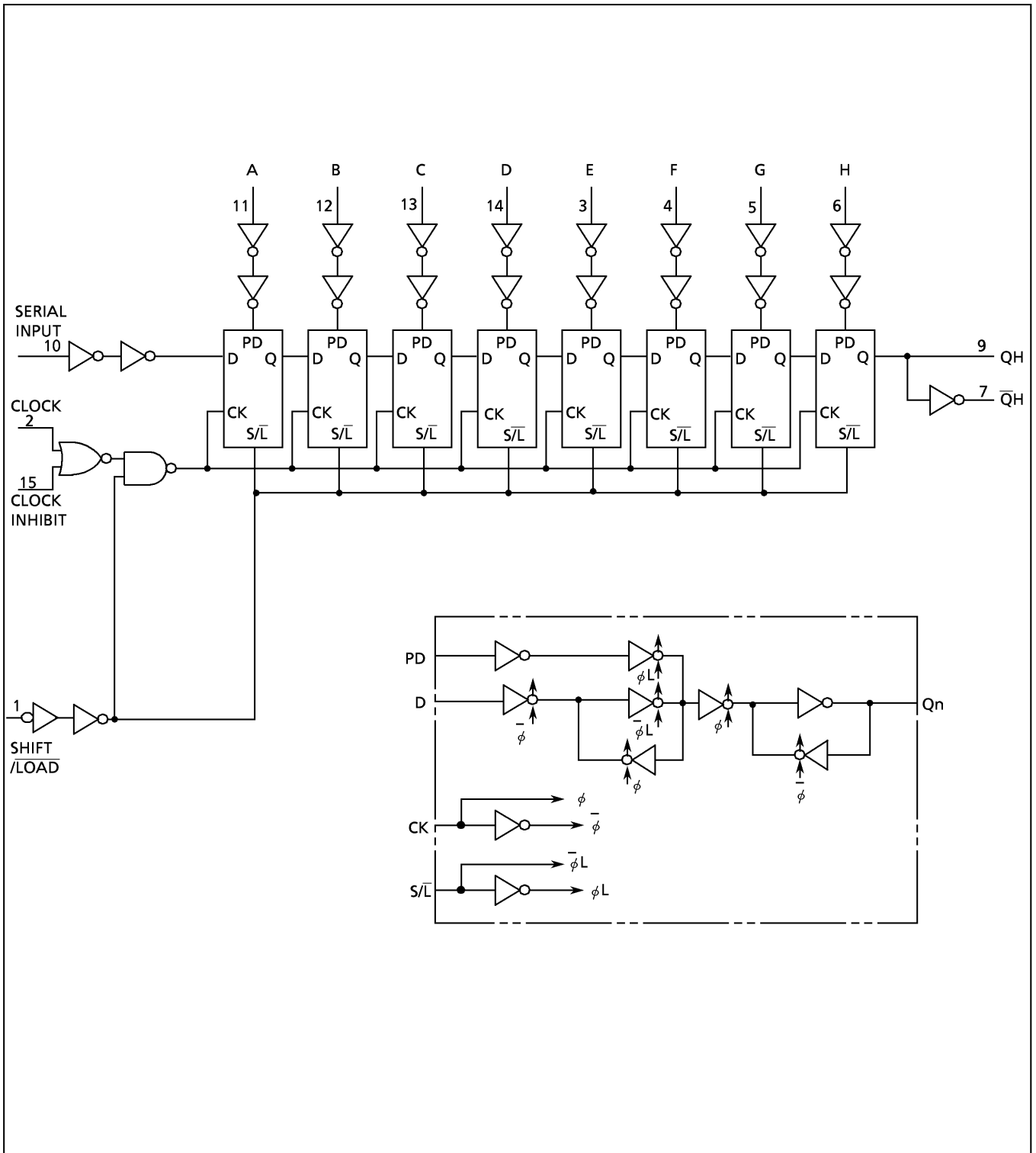

Absolute Maximum Ratings

PARAMETER	SYMBOL	VALUE	UNIT
Supply Voltage Range	V_{CC}	-0.5~7.0	V
DC Input Voltage	V_{IN}	-0.5~7.0	V
DC Output Voltage	V_{OUT}	-0.5~ $V_{CC} + 0.5$	V
Input Diode Current	I_{IK}	-20	mA
Output Diode Current	I_{OK}	± 20	mA
DC Output Current	I_{OUT}	± 25	mA
DC V_{CC} /Ground Current	I_{CC}	± 50	mA
Power Dissipation	P_D	180	mW
Storage Temperature	T_{stg}	-65~150	$^{\circ}C$

Recommended Operating Conditions

PARAMETER	SYMBOL	VALUE	UNIT
Supply Voltage	V_{CC}	2.0~5.5	V
Input Voltage	V_{IN}	0~5.5	V
Output Voltage	V_{OUT}	0~ V_{CC}	V
Operating Temperature	T_{opr}	-40~85	$^{\circ}C$
Input Rise and Fall Time	dt / dv	0~100 ($V_{CC} = 3.3 \pm 0.3V$) 0~20 ($V_{CC} = 5 \pm 0.5V$)	ns / V

DC Electrical Characteristics

PARAMETER	SYMBOL	TEST CONDITION		V_{CC} (V)	$T_a = 25^{\circ}C$			$T_a = -40 \sim 85^{\circ}C$		UNIT	
					Min	Typ.	Max	Min	Max		
High - Level Input Voltage	V_{IH}			2.0 3.0~5.5	1.50 $V_{CC} \times 0.7$	- -	- -	1.50 $V_{CC} \times 0.7$	- -	V	
Low - Level Input Voltage	V_{IL}			2.0 3.0~5.5	- -	- -	0.50 $V_{CC} \times 0.3$	- -	0.50 $V_{CC} \times 0.3$	V	
High - Level Output Voltage	V_{OH}	$V_{IN} = V_{IH}$ or V_{IL}	$I_{OH} = -50\mu A$	2.0 3.0 4.5	1.9 2.9 4.4	2.0 3.0 4.5	- - -	1.9 2.9 4.4	- - -	V	
			$I_{OH} = -4mA$	3.0 4.5	2.58 3.94	- -	- -	2.48 3.80	- -		
			$I_{OH} = -8mA$	3.0 4.5	- -	- -	- -	0.36 0.36	- -		0.44 0.44
Low - Level Output Voltage	V_{OL}	$V_{IN} = V_{IH}$ or V_{IL}	$I_{OL} = 50\mu A$	2.0 3.0 4.5	- - -	0.0 0.0 0.0	0.1 0.1 0.1	- - -	0.1 0.1 0.1	V	
			$I_{OL} = 4mA$	3.0 4.5	- -	- -	- -	0.36 0.36	- -		0.44 0.44
			$I_{OL} = 8mA$	3.0 4.5	- -	- -	- -	0.36 0.36	- -		0.44 0.44
Input Leakage Current	I_{IN}	$V_{IN} = 5.5V$ or GND		0~5.5	-	-	± 0.1	-	± 1.0	μA	
Quiescent Supply Current	I_{CC}	$V_{IN} = V_{CC}$ or GND		5.5	-	-	4.0	-	40.0		

Timing Requirements (Input $t_r = t_f = 3ns$)

PARAMETER	SYMBOL	TEST CONDITION	Ta = 25°C		Ta = -40~85°C		UNIT
			V _{CC} (V)	Limit	Limit	Limit	
Minimum Pulse Width (CK, CK INH)	$t_{W(L)}$ $t_{W(H)}$		3.3 ± 0.3	6.0	7.0	ns	
			5.0 ± 0.5	4.0	4.0		
Minimum Pulse Width (S/ \bar{L})	$t_{W(L)}$		3.3 ± 0.3 5.0 ± 0.5	7.5 5.0	9.0 6.0		
Minimum Set-up Time (PI-S/ \bar{L})	t_s		3.3 ± 0.3 5.0 ± 0.5	7.5 5.0	8.5 5.0		
Minimum Set-up Time (SI-CK, CK INH)	t_s		3.3 ± 0.3 5.0 ± 0.5	5.0 4.0	6.0 4.0		
Minimum Set-up Time (S/ \bar{L} -CK, CK INH)	t_s		3.3 ± 0.3 5.0 ± 0.5	5.0 4.0	6.0 4.0		
Minimum Hold Time (PI-S/ \bar{L})	t_h		3.3 ± 0.3 5.0 ± 0.5	0.5 1.0	0.5 1.0		
Minimum Hold Time (SI-CK, CK INH)	t_h		3.3 ± 0.3 5.0 ± 0.5	0.0 0.5	0.0 0.5		
Minimum Hold Time (S/ \bar{L} -CK, CK INH)	t_h		3.3 ± 0.3 5.0 ± 0.5	0.0 0.5	0.0 0.5		
Minimum Removal Time (CK INH-CK) (CK-CK INH)	t_{rem}		3.3 ± 0.3	5.0	5.0		
			5.0 ± 0.5	3.5	3.5		

AC Electrical Characteristics (Input $t_r = t_f = 3ns$)

PARAMETER	SYMBOL	TEST CONDITION		Ta = 25°C			Ta = -40~85°C		UNIT
		V _{CC} (V)	CL (pF)	Min	Typ.	Max	Min	Max	
Propagation Delay Time (CK, CK INH-QH, QH)	t _{pLH}	3.3 ± 0.3	15	—	9.9	15.4	1.0	18.0	ns
			50	—	12.4	18.9	1.0	21.5	
	5.0 ± 0.5	15	—	6.6	9.9	1.0	11.5		
		50	—	8.1	11.9	1.0	13.5		
Propagation Delay Time (S/L-QH, QH)	t _{pLH}	3.3 ± 0.3	15	—	9.9	15.8	1.0	18.5	
			50	—	12.4	19.3	1.0	22.0	
	5.0 ± 0.5	15	—	6.7	9.9	1.0	11.5		
		50	—	8.2	11.9	1.0	13.5		
Propagation Delay Time (H-QH, QH)	t _{pLH}	3.3 ± 0.3	15	—	9.2	14.1	1.0	16.5	
			50	—	11.7	17.6	1.0	20.0	
	5.0 ± 0.5	15	—	5.9	9.0	1.0	10.5		
		50	—	7.4	11.0	1.0	12.5		
Maximum Clock Frequency	f _{MAX}	3.3 ± 0.3	15	65	85	—	55	—	MHz
			50	60	105	—	50	—	
		5.0 ± 0.5	15	110	150	—	90	—	
			50	95	130	—	85	—	
Input Capacitance	C _{IN}			—	4	10	—	10	pF
Power Dissipation Capacitance	C _{PD}	(Note 1)		—	50	—	—	—	

Note (1): C_{PD} is defined as the value of the internal equivalent capacitance which is calculated from the operating current consumption without load.

Average operating current can be obtained by the equation:

$$I_{CC(opr.)} = C_{PD} \cdot V_{CC} \cdot f_{IN} + I_{CC}$$

Input Equivalent Circuit

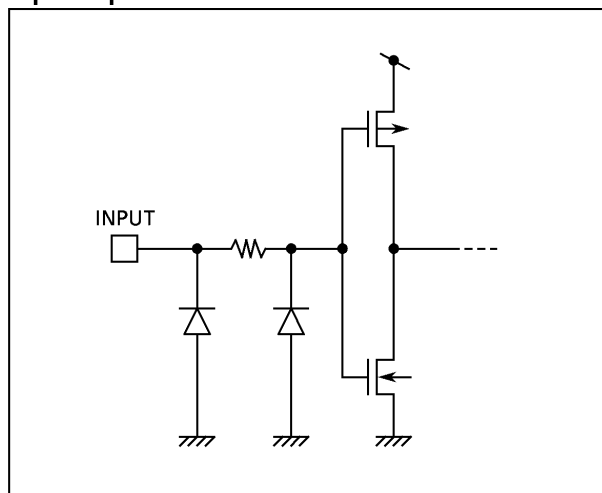

Outline Drawing
VSSOP16-P-0030-0.50

Unit: mm

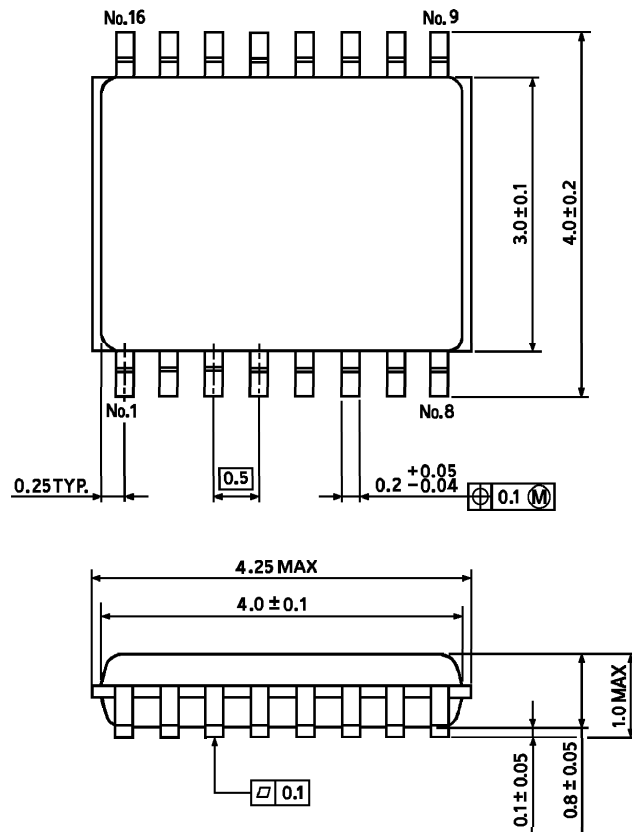

Weight: 0.02g (Typ.)