



SKAI Solutions

1200V IGBT Advanced Drive System

SKAI 3001GD12 1452 W
SemiKron Advanced
Integration (SKAI) module
Liquid-cooled version

Preliminary Data

Features

- 1200V Trench IGBT technology on AlN DCB substrate
- Integrated DC-link film capacitor
- Pressure contact technology for improved power cycling performance
- Optimal thermal management with integrated liquid-cooled heatsink
- Two integrated current sensors with option to include three
- Integrated gate drive and power supply with under-voltage protection. 25-pin DB connector is standard on driver only versions
- Option to include an integrated controller based on TMS320LF2407ADSP. 14-pin AMP SEAL connector is standard on controller versions.

Typical Applications

- Vehicles
- Hybrid vehicles
- Motor Drives
- Regenerative Drives

¹⁾ Contact SEMIKRON for power loss calculations

²⁾ "s" referenced to built-in Temp. Sensor

³⁾ 50% Water, 50% Glycol

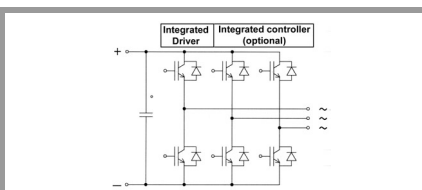

SKAI

Circuit	I_{rms}	V_{dc}	Types
B6CI	300	900	SKAI 3001GD12 1452 W

Symbol	Conditions	Values	Units
$I_{rms}^{1)}$	no overload, $T_{coolant}= 50^{\circ}C$, 5kHz, p.f.=0,8 overload, $t<20s$	300 400	A A
V_{CES}		1200	V
V_{CEO}	IGBT $T_j= 125^{\circ}C$	0,85	V
r_{CE}	$T_j= 125^{\circ}C$	3,1	m Ω
V_{CESat}	400A, $T_j= 25 / 125^{\circ}C$	1,76 / 2,2	V
$E_{ON} + E_{OFF}$	$V_{cc}= 600/800V$, $I_c= 400A$, $T_j= 125^{\circ}C$	101 / 151	mJ
V_{TO}	Inverse diode $T_j= 125^{\circ}C$	0,80	V
r_T	$T_j= 125^{\circ}C$	1,87	m Ω
$V_F=V_{EC}$	400A, $T_j= 25 / 125^{\circ}C$	1,56 / 1,55	V
$E_{ON} + E_{OFF}$	$V_{cc}= 600/800V$, $I_c= 400A$, $T_j= 125^{\circ}C$	32 / 38	mJ
$R_{thjs}^{2)}$	Thermal Characteristics / Heatsink per IGBT	0,065	K/W
$R_{thjs}^{2)}$	per diode	0,13	K/W
$R_{thsa}^{2)}$	Heatsink to coolant ³⁾ , flow rate $V_f= 15$ l/min	9,3	K/kW
	Heatsink to coolant ³⁾ , flow rate $V_f= 5$ l/min	13,4	K/kW
P_{ADR}	Pressure drop, Coolant flow rate $V_f= 5$ l/min	0,05	bar
	Pressure drop, Coolant flow rate $V_f= 15$ l/min	0,55	bar
C_{eqvl}	Capacitor bank total equivalent capacitance	1	mF
V_{DCmax}	max. DC voltage applied to capacitor bank	900	V
V_s	Driver Power supply: typ value	24	V
	Power supply: min / max values	8 / 30	V
I_s	Supply current	500	mA
dV/dt	Primary to Secondary Side	15	kV/ μ s
f_{SWmax}	Max. Switching Frequency	15	kHz
V_{isol}	power terminals to heatsink and signal connector: AC, 1 min.	3000	V
T_{vj}	Junction temperature	-40...+150	$^{\circ}C$
T_{stg}	Storage Temperature	-40...+125	$^{\circ}C$
T_{amb}	Operating ambient temperature	-40...+85	$^{\circ}C$
I_{TRIPSC}	Protection Short Circuit Protection	1000	A
T_{TRIP}	Over-Temp. Protection	115	$^{\circ}C$
U_{DCTRIP}	V_{CC} Overvoltage Protection	917	V
$L \times W \times H$	Dimensions Length x Width x Height	400 x 215 x 100	mm
w	approx.	8,2	kg

SEMISTACK - SKAI

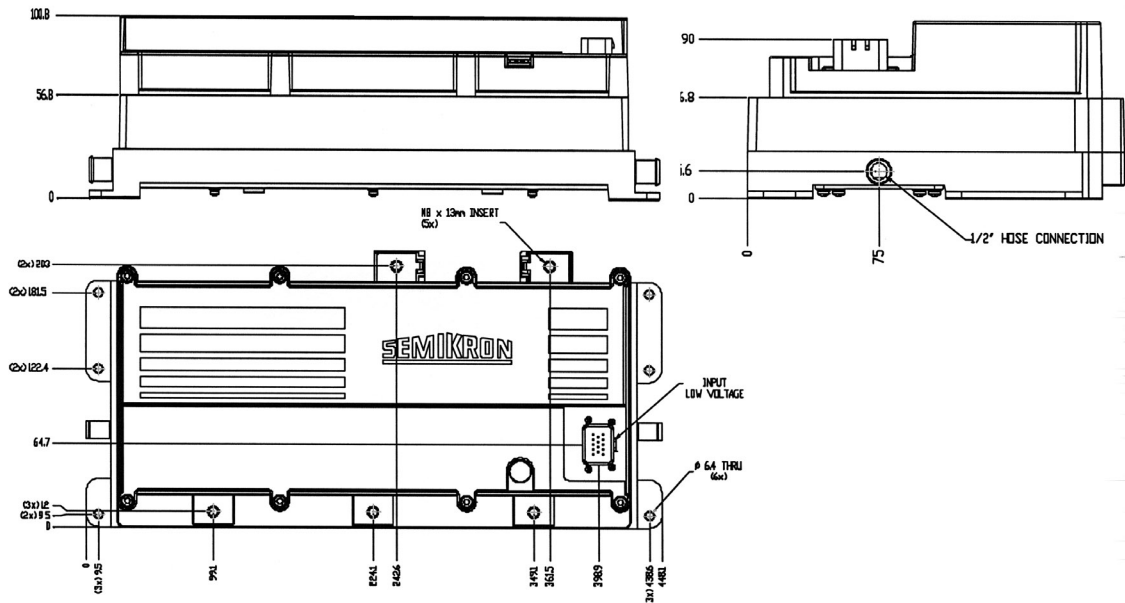

SKAI 3001GD12 1452 W: General dimensions

This technical information specifies semiconductor devices but promises no characteristics. No warranty or guarantee expressed or implied is made regarding delivery, performance or suitability.