

## R485-Type Lightwave Receiver with Clock Recovery for 2.488 Gbits/s Applications



Manufactured in a low-profile, 24-pin package, the R485-Type Receiver features either an avalanche or PIN photodetector, a transimpedance amplifier, a limiting amplifier, and a clock and data recovery IC.

### Features

- Multisourced footprint
- Internal APD bias supply
- Differential data and clock outputs
- APD and PIN versions
- Typical sensitivity:
  - APD, -32 dBm
  - PIN, -23 dBm
- Operation at 1.3  $\mu\text{m}$  or 1.55  $\mu\text{m}$
- TTL link status flag
- Wide operating case temperature range:
  - APD, 0  $^{\circ}\text{C}$  to +70  $^{\circ}\text{C}$
  - PIN, -40  $^{\circ}\text{C}$  to +85  $^{\circ}\text{C}$
- Space-saving, self-contained, 24-pin DIP

- Agere Systems Inc. Reliability and Qualification Program for built-in quality
- SONET/SDH compatible for OC-48/STM-16 data rate

### Applications

- Telecommunications
  - Inter- and intraoffice SONET/SDH
  - Subscriber loop
  - Metropolitan area networks
- High-speed data communications

### Description

The R485-Type 2.5 Gbits/s lightwave receiver is designed for use in SONET OC-48 and synchronous digital hierarchy (SDH) STM-16 telecommunications applications and high-speed data communications applications. The receiver converts received optical signals in the range of 1.2  $\mu\text{m}$  to 1.6  $\mu\text{m}$  wavelength into differential data and clock outputs. The receiver consists of either InGaAs APD or PIN photodetector (depending on model selected), a transimpedance amplifier, a limiting amplifier, and a clock and data recovery IC (CDR). The CDR uses PLL technology to extract the clock signal from the converted optical signal. A TTL compatible link status flag signal indicates when there is a loss of optical signal.

The receiver is manufactured in a low-profile, pig-tailed, 24-pin plastic DIP package. It requires a single, +5.0 V power supply. The APD version has the added benefit of containing the high-voltage supply internal to the receiver. This internal supply also provides the necessary temperature compensation for the APD.

## Flag Output

When the incoming optical signal falls below the link-status switching threshold, the FLAG output is asserted and the FLAG output logic level changes from a TTL low to a TTL high.

## Pin Information

Table 1. Pin Information

Pin	Name	Pin	Name
1	NIC	24	NUC*
2	NUC*	23	NUC*
3	LOS Flag <sup>†</sup>	22	Vcc
4	Ground	21	NUC*
5	$\overline{\text{CLOCK}}$	20	Ground
6	CLOCK	19	Ground
7	Ground	18	NIC
8	Vcc	17	Ground
9	Ground	16	Ground
10	DATA	15	Ground
11	$\overline{\text{DATA}}$	14	Ground
12	Ground	13	DTV/NIC <sup>‡</sup>

\* Pins designated as no user connect (NUC) are connected internally. The user should not make any connections to these pins.

† The loss of signal (LOS) FLAG output is a logic level that indicates the presence or absence of a minimum acceptable level of optical input. A TTL logic HIGH indicates the absence of a valid optical input signal.

‡ This pin is not internally connected if the amplitude decision threshold (DTV) is not made adjustable.

## Handling Precautions

The R485-Type receiver is manufactured with a 39 in.  $\pm$  4 in. (100 cm  $\pm$  10 cm) single-mode fiber pigtail with a 900  $\mu$ m OD PVC outer jacket. Both SC and FC-PC connectors are offered on standard versions. Other optical connector options are available on special order. Please contact an Agere Systems Account Manager for availability and ordering information.

The minimum fiber bending radius is 1.5 inches (38 mm).

## Receiver Processing

The R485-Type receiver devices can withstand normal wave soldering processes. The complete receiver module is not hermetically sealed; therefore, it should not be immersed in, or sprayed with, any solutions. The optical connector process cap deformation temperature is 85 °C. The receiver pins can be wave soldered at 250 °C for 10 seconds.

## Electrostatic Discharge

**CAUTION: This device is susceptible to damage as a result of electrostatic discharge (ESD). Take proper precautions during both handling and testing. Follow guidelines such as JEDEC Publication No. 108-A (Dec. 1988).**

Although protection circuitry is designed into the device, take proper precautions to avoid exposure to ESD.

Agere employs a human-body model (HBM) for ESD-susceptibility testing and protection design evaluation. ESD voltage thresholds are dependent on the critical parameters used to define the model. A standard HBM (resistance = 1.5 k $\Omega$ , capacitance = 100 pF) is widely used and, therefore, can be used for comparison purposes.

## Installation Considerations

Although the receiver has been designed with ruggedness in mind, care should be used during handling. The optical connector should be kept free from dust. The optical connector process cap should be kept in place as a dust cover when the device is not connected to a cable. If contamination is present on the optical connector, the use of canned air with an extension tube should remove any loose debris. Other cleaning procedures are outlined in the *Cleaning Fiber Optic Assemblies* Technical Note (TN95-010LWP).

The cable should be handled conservatively with no excessive axial pulling or lateral tugging.

## Absolute Maximum Ratings

Stresses in excess of the absolute maximum ratings can cause permanent damage to the device. These are absolute stress ratings only. Functional operation of the device is not implied at these or any other conditions in excess of those given in the operational sections of the data sheet. Exposure to absolute maximum ratings for extended periods can adversely affect device reliability.

Parameter	Symbol	Min	Max	Unit
Operating Case Temperature Range:	T <sub>C</sub>	0	70	°C
	T <sub>C</sub>	-40	85	°C
Storage Temperature	T <sub>stg</sub>	-40	85	°C
Optical Input Power—Biased:	P <sub>IN</sub>	—	0	dBm
	P <sub>IN</sub>	—	8	dBm
Supply Voltages	V <sub>CC</sub>	0	6.5	V
Lead Soldering Temperature/Time	—	—	250/10	°C/s

## Characteristics

**Table 2. Optical Characteristics**

At 1.3 μm wavelength and 1 x 10<sup>-10</sup> BER with 2<sup>23</sup> - 1 NRZ pseudorandom data.

Parameter	Symbol	Min*	Typ†	Max*	Unit
Measured Average Sensitivity:	P <sub>MIN</sub>	—	-32	-30	dBm
	P <sub>MIN</sub>	—	-23	-21	dBm
Maximum Input Power:	P <sub>MAX</sub>	-8	—	—	dBm
	P <sub>MAX</sub>	0	—	—	dBm
Link Status Switching Threshold Decreasing Light Input:	LSTD	-45	-40	-35	dBm
	LSTD	-34	-27	-24	dBm
Flag Response Time	t <sub>FLAG</sub>	3	—	1000	μs
Flag Hysteresis	—	1.2	—	—	dB
Optical Reflectance:	—	—	—	-27	dB
	—	—	—	-14	dB

\* Over operating temperature range and at end of life.

† Typical values at room temperature and beginning of life.

**Characteristics** (continued)

**Table 3. Electrical Characteristics**

Parameter	Symbol	Min	Typ*	Max	Unit
Bit Rate	—	2488.07	2488.32	2488.57	Mbits/s
dc Power Supply Voltages	V <sub>CC</sub>	4.75	5.0	5.25	V
Power Consumption	—	—	1.3	2.0	W
Output Data/Clock Voltage:†					
Single Output	SV	0.3	0.4	1.0	Vp-p
Differential Output	DV	0.6	0.8	2.0	Vp-p
Output Flag Voltage:‡					
High	V <sub>FOH</sub>	2.5	5.0	V <sub>CC</sub>	V
Low	V <sub>FOL</sub>	0	0.2	0.8	V
Clock/Data Alignment (see Figure 1)	t <sub>CDA</sub>	—	0	±40	ps
Clock Duty Cycle	—	45	50	55	%
Jitter Generation	J <sub>G</sub>	—	0.005	<0.01	UI rms
Jitter Transfer (see Figure 2)	J <sub>P</sub>	—	—	<0.1	dB
Jitter Tolerance (see Figure 3)	<i>Telcordia Technologies™</i> GR-253-Core and ITU-T G.958 Compliant				

\* Typical values measured at room temperature and beginning of life.

† Measured with a 50 Ω to ground. Outputs must be ac-coupled (see Figure 2).

‡ TTL output.

Characteristic Curves

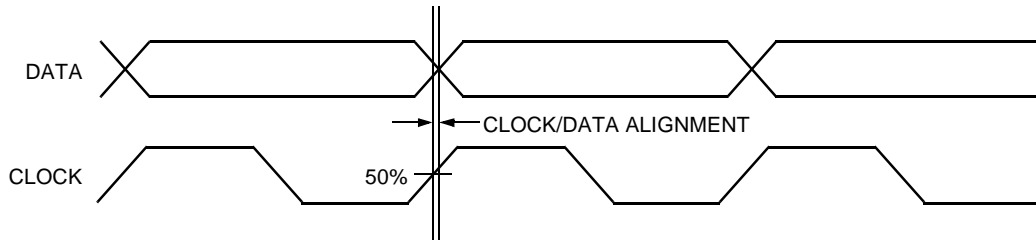

1-1313(F)

Figure 1. Clock/Data Alignment

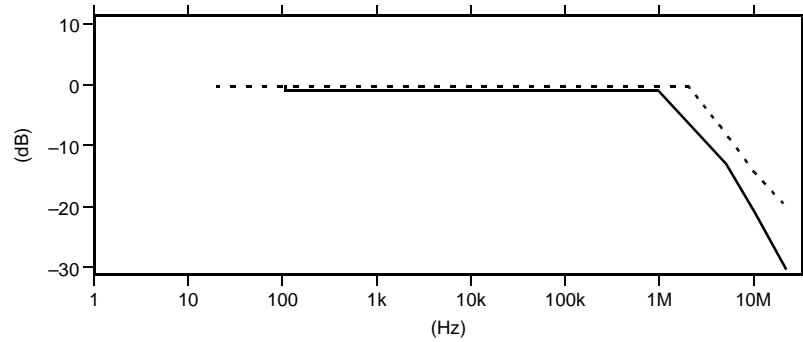

1-1127(F)

Figure 2. Jitter Transfer

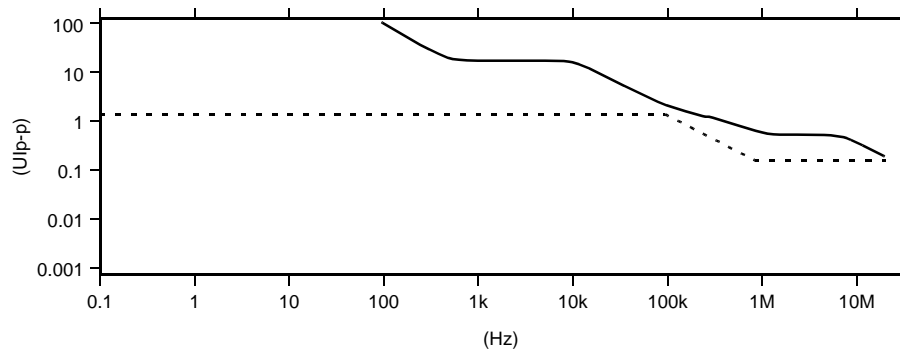

1-1128(F)

Figure 3. Jitter Tolerance

## Qualification and Reliability

The R485-type receiver is scheduled to complete the following qualification tests to meet the intent of *Telcordia Technologies* GR-468-CORE.

**Table 4. R485 Qualification Information**

Test	Reference	Conditions	Code Type	Sample Size	Pass/Fail Criteria	Note
Mechanical Shock	MIL-STD-883 Method 2002	Condition B 5 times/axis 500 G, 1 ms	R485 R480	11 Pieces	Change in Receiver Sensitivity: -1.5 dB	Qualified by T48/P172
Sine Vibration	MIL-STD-883 Method 2007	Condition A 20 G, 20 Hz—2000 Hz 4 min./cycle 4 cycles/axis	R485 R480	11 Pieces	Change in Receiver Sensitivity: -1.5 dB	Qualified by T48/P172
Thermal Shock	MIL-STD-883 Method 1011	$\Delta T = 100\text{ }^{\circ}\text{C}$	R485 R480	11 Pieces	Physical Attributes and Leak Check	Qualified by T48/P172
Solderability	MIL-STD-883 Method 2003	(Package Supplier Test)	—	—	—	Qualified by T48
Lead Integrity	MIL-STD-883 Method 2004	(Package Supplier Test)	—	—	—	Qualified by T48
Solvent Resistance	MIL-STD-883 Method 2015	(Package Supplier Test)	—	—	—	Qualified by T48
Fiber Pull	GR-468-CORE Table 6	1 kg; 3 times; 5 s	R485 R480	11 Pieces	Change in Receiver Sensitivity: -1.5 dB	Qualified by P172
Accelerating Aging (HTOB)	MIL-STD-883 Method 1005	85 °C under bias, 2000 hours	R485 R480	25 Pieces	Change in Receiver Sensitivity: -1.5 dB	Qualified by T48/P172; Refer to Chip Data
High Temperature Storage	GR-468-CORE Table 6	85 °C storage, 2000 hours	R485 R480	11 Pieces	Change in Receiver Sensitivity: -1.5 dB	Qualified by T48/P172
Temperature Cycling	GR-468-CORE Section 5.20	-40 °C to +85 °C 100 Cycles for Pass/Fail	R485 R480	11 Pieces	Change in Receiver Sensitivity: -1.5 dB	Qualified by T48/P172
Temperature Humidity Bias	GR-468-CORE Table 6	85 °C/85% RH 1000 hours	R485 R480	11 Pieces	Change in Receiver Sensitivity: -1.5 dB	Qualified by T48/P172
Internal Water Vapor	MIL-STD-883 Method 1018	5000 ppm Water Vapor	R485 R480	11 Pieces	Change in Receiver Sensitivity: -1.5 dB	Qualified by T48/P172
ESD	GR-468-CORE Section 5.22	Human-Body Model	R485 R480	6 Pieces	Threshold Minimum: 500 V	—

## PWB Layout Guidelines

- The data and clock outputs are designed to drive 50  $\Omega$  loads.
- Clock and data output traces must be controlled-impedance lines and the termination impedance must match the line impedance. Avoid 90° bends in the traces. Paired lines (i.e., DATA and  $\overline{\text{DATA}}$ ) must be equal in length.
- Data and clock output lines should be as short and straight as possible and should be shielded from noise sources to prevent noise from feeding back into the receiver.
- Use high-quality multilayer printed-wiring boards. A ground plane should occupy the area directly beneath the receiver.

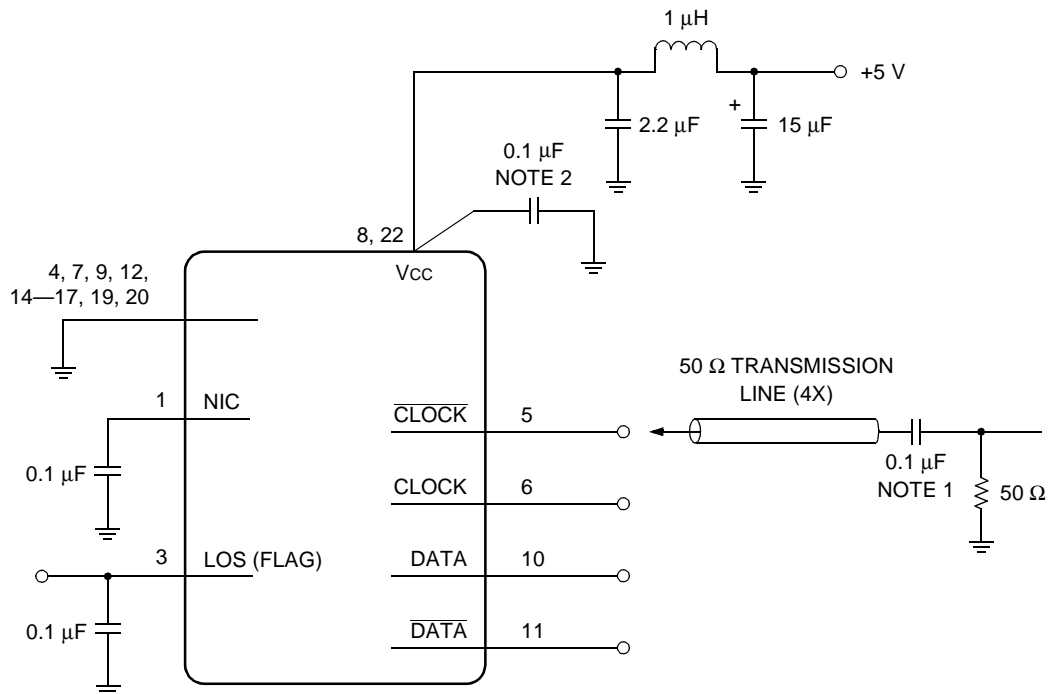

1-934(F)xxx

Note 1: Data and clock outputs must be ac-coupled on customer board. Use a 0.1  $\mu\text{F}$  chip capacitor with a low ESR. For optimum receiver performance, all four outputs must be terminated in equivalent loads, even if some of the outputs are not being used.

Note 2: The 0.1  $\mu\text{F}$  Vcc power supply bypass capacitors should be high-quality, low ESR chip capacitors that are located as close as possible to the appropriate power supply leads and should provide a low inductance path to the ground plane.

**Figure 4. Biasing and Interfacing to the R485-Type 2.5 Gbits/s Receiver**

## Outline Diagrams

Dimensions are in inches and (millimeters).

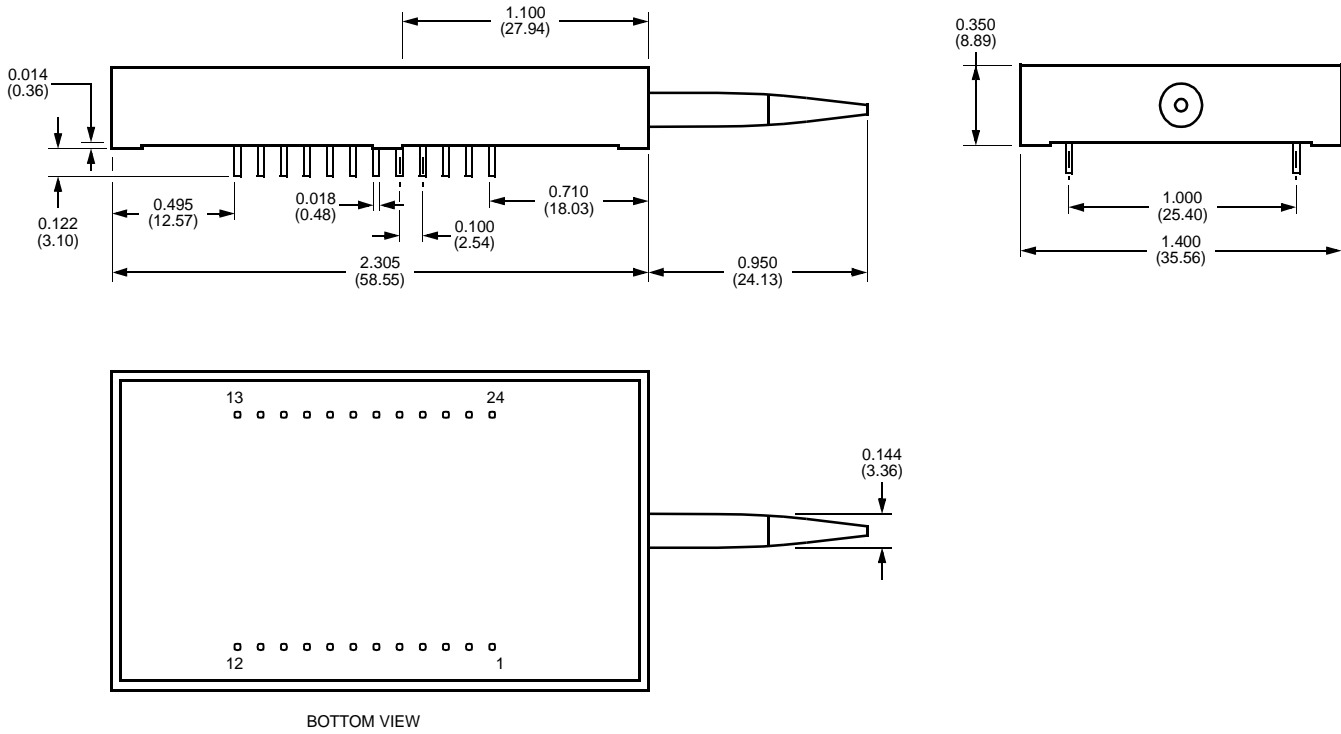

1-999(F)



## Ordering Information

Table 5. Ordering Information for the R485-Type Receiver

Code	Detector Type	Connector Type	Fiber Type	Comcode
R485CMAA	APD	SC/PC	Single-Mode	108514597
R485FMAA	APD	FC/PC	Single-Mode	108514613
R485WMAA	APD	LC	Single-Mode	TBD
R485JMAA	APD	MU	Single-Mode	TBD
R485CPAA	PIN	SC/PC	Single-Mode	108514605
R485FPAA	PIN	FC/PC	Single-Mode	108514621
R485WPAA	PIN	LC	Single-Mode	TBD
R485JPAA	PIN	MU	Single-Mode	TBD
R485CPBB	PIN	SC/PC	Multimode	TBD
R485FPBB	PIN	FC/PC	Multimode	TBD
R485WPBB	PIN	LC	Multimode	TBD
R485JPBB	PIN	MU	Multimode	TBD

Table 6. Related Product Information

Product Code	Description	Document Number
T48 Transmitter	2.5 Gbits/s Uncooled Laser Transmitter	DS00-088OPTO

*Telcordia Technologies* is a trademark of Telcordia Technologies Inc.

---

For additional information, contact your Agere Systems Account Manager or the following:

INTERNET: <http://www.agere.com>

E-MAIL: [docmaster@agere.com](mailto:docmaster@agere.com)

N. AMERICA: Agere Systems Inc., 555 Union Boulevard, Room 30L-15P-BA, Allentown, PA 18109-3286

**1-800-372-2447**, FAX 610-712-4106 (In CANADA: **1-800-553-2448**, FAX 610-712-4106)

ASIA: Agere Systems Hong Kong Ltd., Suites 3201 & 3210-12, 32/F, Tower 2, The Gateway, Harbour City, Kowloon

**Tel. (852) 3129-2000**, FAX (852) 3129-2020

CHINA: **(86) 21-5047-1212** (Shanghai), **(86) 10-6522-5566** (Beijing), **(86) 755-695-7224** (Shenzhen)

JAPAN: **(81) 3-5421-1600** (Tokyo), KOREA: **(82) 2-767-1850** (Seoul), SINGAPORE: **(65) 778-8833**, TAIWAN: **(886) 2-2725-5858** (Taipei)

EUROPE: **Tel. (44) 7000 624624**, FAX (44) 1344 488 045

---

Agere Systems Inc. reserves the right to make changes to the product(s) or information contained herein without notice. No liability is assumed as a result of their use or application.