

SURFACE MOUNT LED LAMP

Right Angle - (Side Looker)

PACKAGE DIMENSIONS

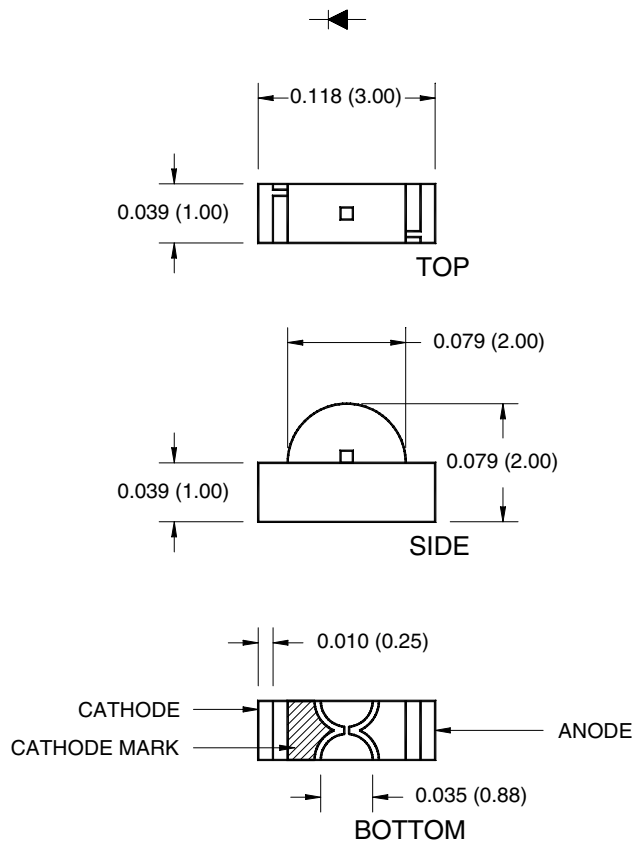

NOTE:
Dimensions are in inches (mm).

PURE GREEN
SOFT ORANGE

QTLP610C-5
QTLP610C-8

FEATURES

- Ultra-miniature
- Wide viewing angle of 140°
- Water clear optics
- Available in 0.315" (8mm) width tape on 7" (178mm) diameter
- Moisture-proof packaging

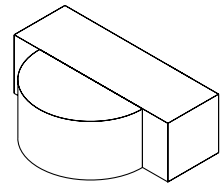

DESCRIPTION

These right angle surface mount lamps emit light in the lateral direction and are particularly suitable for edge lighting LCDs, edge-cards, as well as other standard printed circuit board applications.

ABSOLUTE MAXIMUM RATINGS (T_A = 25°C unless otherwise specified)

Parameter	Pure Green QTLP610C-5	Soft Orange QTLP610C-8	Units
Continuous Forward Current - I _F	30	30	mA
Peak Forward Current - I _F (f = 1.0 KHz, Duty Factor = 1/10)	160	160	mA
Reverse Voltage - V _R (I _R = 10 μA)	5	5	V
Power Dissipation - P _D	100	100	mW
Operating Temperature - T _{OPR}	-40 to +100		°C
Storage Temperature - T _{STG}	-40 to +100		°C
Lead Soldering Time - T _{SOL}			
Wave	260 for 5 sec		°C
Reflow	260 for 10 sec		

PURE GREEN
SOFT ORANGE

QTLP610C-5
QTLP610C-8

ELECTRICAL / OPTICAL CHARACTERISTICS (T_A = 25°C)

Part Number	Pure Green QTLP610C-5	Soft Orange QTLP610C-8	Condition
Luminous Intensity (mcd)			I _F = 20 mA
Minimum	2.0	3.0	
Typical	4.0	6.0	
Forward Voltage (V)			I _F = 20 mA
Maximum	2.8	2.8	
Typical	2.1	2.1	
Peak Wavelength (nm)	555	610	I _F = 20 mA
Spectral Line Half Width (nm)	30	40	I _F = 20 mA
Viewing Angle (°)	140	140	I _F = 20 mA

TYPICAL PERFORMANCE CURVES

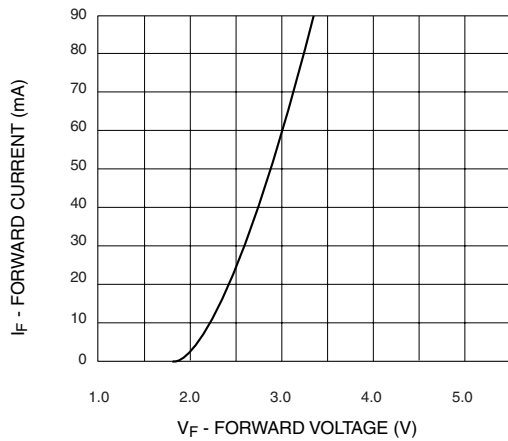

Fig. 1 Forward Current vs. Forward Voltage

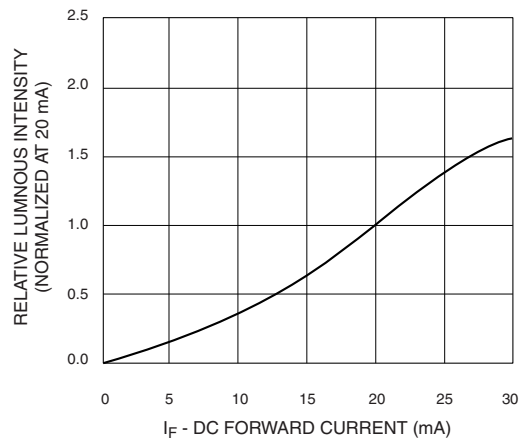

Fig. 2 Relative Luminous Intensity vs. DC Forward Current

PURE GREEN
SOFT ORANGE

QTLP610C-5
QTLP610C-8

TYPICAL PERFORMANCE CURVES

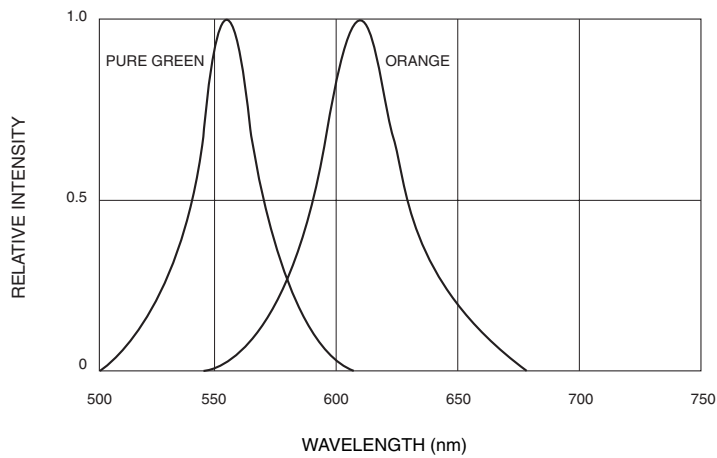

Fig. 3 Relative Intensity vs. Peak Wavelength

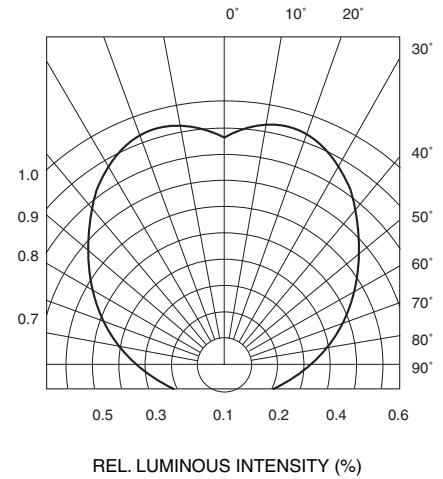

Fig. 4 Radiation Diagram

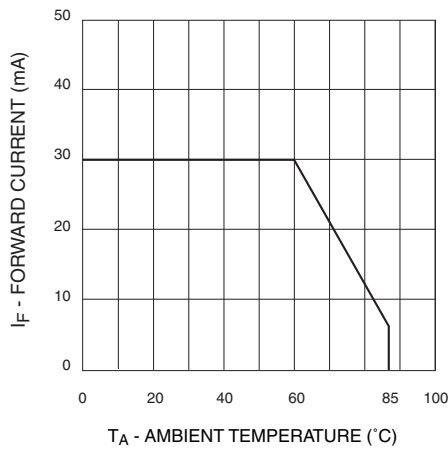

Fig. 5 Current Derating Curve

SURFACE MOUNT LED LAMP

Right Angle - (Side Looker)

PURE GREEN
SOFT ORANGE

QTLP610C-5
QTLP610C-8

RECOMMENDED PRINTED CIRCUIT BOARD PATTERN

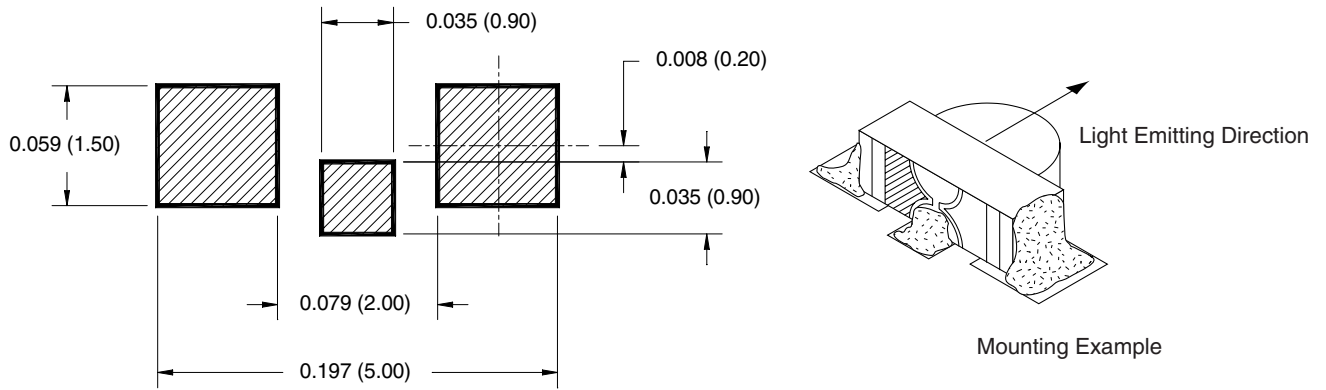

RECOMMENDED IR REFLOW SOLDERING PROFILE

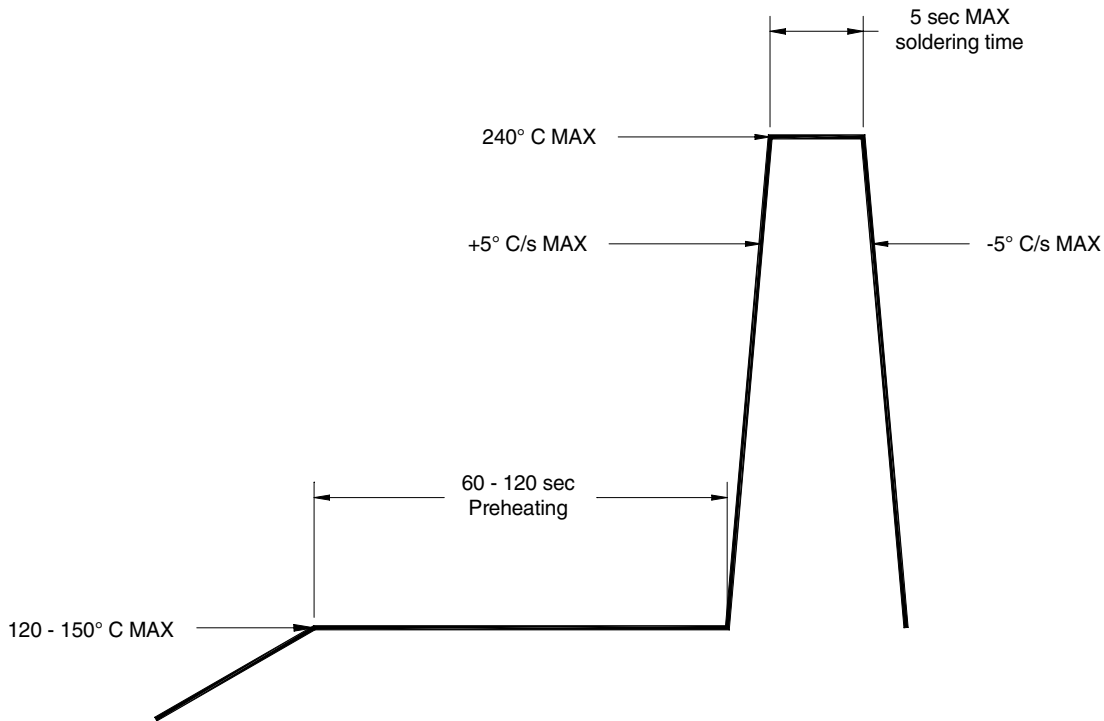

DISCLAIMER

FAIRCHILD SEMICONDUCTOR RESERVES THE RIGHT TO MAKE CHANGES WITHOUT FURTHER NOTICE TO ANY PRODUCTS HEREIN TO IMPROVE RELIABILITY, FUNCTION OR DESIGN. FAIRCHILD DOES NOT ASSUME ANY LIABILITY ARISING OUT OF THE APPLICATION OR USE OF ANY PRODUCT OR CIRCUIT DESCRIBED HEREIN; NEITHER DOES IT CONVEY ANY LICENSE UNDER ITS PATENT RIGHTS, NOR THE RIGHTS OF OTHERS.

LIFE SUPPORT POLICY

FAIRCHILD'S PRODUCTS ARE NOT AUTHORIZED FOR USE AS CRITICAL COMPONENTS IN LIFE SUPPORT DEVICES OR SYSTEMS WITHOUT THE EXPRESS WRITTEN APPROVAL OF THE PRESIDENT OF FAIRCHILD SEMICONDUCTOR CORPORATION. As used herein:

1. Life support devices or systems are devices or systems which, (a) are intended for surgical implant into the body, or (b) support or sustain life, and (c) whose failure to perform when properly used in accordance with instructions for use provided in the labeling, can be reasonably expected to result in a significant injury of the user.
2. A critical component in any component of a life support device or system whose failure to perform can be reasonably expected to cause the failure of the life support device or system, or to affect its safety or effectiveness.