

# NC7SZ18

## TinyLogic® UHS 1-of-2 Non-Inverting Demultiplexer with 3-STATE Deselected Output

### General Description

The NC7SZ18 is a 1-of-2 non-inverting demultiplexer. The device will buffer the data on the A pin and pass to either output  $Y_0$  or  $Y_1$  dependent on whether state of the select pin (S) is LOW or HIGH respectively. The deselected output will be placed into a high impedance state. The device is fabricated with advanced CMOS technology to achieve ultra high speed with high output drive while maintaining low static power dissipation over a broad  $V_{CC}$  operating range. The device is specified to operate over the 1.65V to 5.5V  $V_{CC}$  operating range. The inputs and outputs are high impedance when  $V_{CC}$  is 0V. Inputs tolerate voltages up to 5.5V independent of  $V_{CC}$  operating range.

### Features

- Space saving SC70 6-lead surface mount package
- Ultra small MicroPak™ leadless package
- High Impedance output when deselected
- Ultra High Speed:  $t_{PD}$  2.5 ns Typ into 50 pF at 5V  $V_{CC}$
- Broad  $V_{CC}$  Operating Range; 1.65V to 5.5V
- Power down high impedance inputs/outputs
- Overvoltage tolerant inputs facilitate 5V to 3V translation
- Patented noise/EMI reduction circuitry implemented

### Ordering Code:

Order Number	Package Number	Product Code Top Mark	Package Description	Supplied As
NC7SZ18P6X	MAA06A	Z18	6-Lead SC70, EIAJ SC88, 1.25mm Wide	3k Units on Tape and Reel
NC7SZ18L6X	MAC06A	D5	6-Lead MicroPak, 1.0mm Wide	5k Units on Tape and Reel

### Pin Descriptions

Pin Names	Description
A	Data Input
S	Demultiplexer Select
$Y_0, Y_1$	Outputs

### Function Table

Input		Output	
S	A	$Y_0$	$Y_1$
L	L	L	Z
L	H	H	Z
H	L	Z	L
H	H	Z	H

H = HIGH Logic Level  
L = LOW Logic Level  
Z = 3-STATE

### Connection Diagrams

#### Pin Assignments for SC70

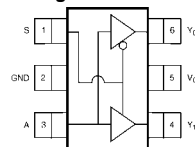

#### Pin One Orientation Diagram

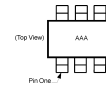

AAA = Product Code Top Mark - see ordering code

**Note:** Orientation of Top Mark determines Pin One location. Read the top product code mark left to right, Pin One is the lower left pin (see diagram).

#### Pad Assignments for MicroPak

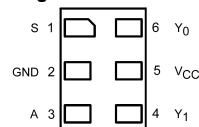

(Top Thru View)

TinyLogic® is a registered trademark of Fairchild Semiconductor Corporation.  
MicroPak™ is a trademark of Fairchild Semiconductor Corporation.

NC7SZ18 TinyLogic® UHS 1-of-2 Non-Inverting Demultiplexer with 3-STATE Deselected Output

Absolute Maximum Ratings <sup>(Note 1)</sup>		Recommended Operating Conditions	
Supply Voltage ( $V_{CC}$ )	-0.5V to +7.0V	Supply Voltage Operating ( $V_{CC}$ )	1.65V to 5.5V
DC Input Voltage ( $V_{IN}$ )	-0.5V to +7.0V	Supply Voltage Data Retention ( $V_{CC}$ )	1.5V to 5.5V
DC Output Voltage ( $V_{OUT}$ )	-0.5V to +7.0V	Input Voltage ( $V_{IN}$ )	0V to 5.5V
DC Input Diode Current ( $I_{IK}$ )		Output Voltage ( $V_{OUT}$ )	0V to $V_{CC}$
@ $V_{IN} \leq -0.5V$	-50 mA	Operating Temperature ( $T_A$ )	-40°C to +85°C
DC Output Diode Current ( $I_{OK}$ )		Input Rise and Fall Time ( $t_r, t_f$ )	
@ $V_{IN} \leq -0.5V$	-50 mA	$V_{CC} @ 1.8V \pm 0.15V, 2.5V \pm 0.2V$	0 ns/V to 20 ns/V
DC Output Current ( $I_{OUT}$ )	$\pm 50$ mA	$V_{CC} @ 3.3V \pm 0.3V$	0 ns/V to 10 ns/V
DC $V_{CC}$ or Ground Current ( $I_{CC}/I_{GND}$ )	$\pm 100$ mA	$V_{CC} @ 5.0V \pm 0.5V$	0 ns/V to 5 ns/V
Storage Temperature Range ( $T_{STG}$ )	-65°C to +150°C	Thermal Resistance ( $\theta_{JA}$ )	350°C/W
Junction Temperature under Bias ( $T_J$ )	150°C	<b>Note 1:</b> Absolute maximum ratings are DC values beyond which the device may be damaged or have its useful life impaired. The datasheet specifications should be met, without exception, to ensure that the system design is reliable over its power supply, temperature, and output/input loading variables. Fairchild does not recommend operation outside datasheet specifications.	
Junction Lead Temperature ( $T_L$ )			
(Soldering, 10 seconds)	260°C		
Power Dissipation ( $P_D$ ) @ +85°C	180 mW		

**DC Electrical Characteristics**

Symbol	Parameter	$V_{CC}$ (V)	$T_A = +25^\circ C$			$T_A = -40^\circ C$ to $+85^\circ C$		Units	Conditions	
			Min	Typ	Max	Min	Max			
$V_{IH}$	HIGH Level Input Voltage	1.65 – 1.95 2.3 – 5.5	0.75 $V_{CC}$ 0.7 $V_{CC}$			0.75 $V_{CC}$ 0.7 $V_{CC}$		V		
$V_{IL}$	LOW Level Input Voltage	1.65 – 1.95 2.3 – 5.5			0.25 $V_{CC}$ 0.3 $V_{CC}$	0.25 $V_{CC}$ 0.3 $V_{CC}$		V		
$V_{OH}$	HIGH Level Output Voltage	1.65	1.55	1.65		1.55		V	$V_{IN} = V_{IH}$	$I_{OH} = -100 \mu A$
		2.3	2.2	2.3		2.2				
		3.0	2.9	3.0		2.9				
		4.5	4.4	4.5		4.4				
		1.65	1.29	1.52		1.29	$I_{OH} = -4 \text{ mA}$ $I_{OH} = -8 \text{ mA}$ $I_{OH} = -16 \text{ mA}$ $I_{OH} = -24 \text{ mA}$ $I_{OH} = -32 \text{ mA}$			
		2.3	1.9	2.15		1.9				
		3.0	2.4	2.80		2.4				
3.0	2.3	3.68		2.3						
4.5	3.8	4.20		3.8						
$V_{OL}$	LOW Level Output Voltage	1.65		0.0	0.10		0.10	V	$V_{IN} = V_{IL}$	$I_{OL} = 100 \mu A$
		2.3		0.0	0.10		0.10			
		3.0		0.0	0.10		0.10			
		4.5		0.0	0.10		0.10			
		1.65		0.08	0.24		0.24			$I_{OL} = 4 \text{ mA}$ $I_{OL} = 8 \text{ mA}$ $I_{OL} = 16 \text{ mA}$ $I_{OL} = 24 \text{ mA}$ $I_{OL} = 32 \text{ mA}$
		2.3		0.10	0.3		0.3			
		3.0		0.15	0.4		0.4			
3.0		0.22	0.55		0.55					
4.5		0.22	0.55		0.55					
$I_{IN}$	Input Leakage Current	0 to 5.5		$\pm 0.1$		$\pm 1$	$\mu A$	$V_{IN} = 5.5V, GND$		
$I_{OZ}$	3-STATE Output Leakage	1.65 to 5.5V		$\pm 0.5$		$\pm 5$	$\mu A$	$V_{IN} = V_{IL}$ or $V_{IH}$ $0 < V_{OUT} \leq 5.5V$		
$I_{OFF}$	Power Off Leakage Current	0.0		1		10	$\mu A$	$V_{IN}$ or $V_{OUT} = 5.5V$		
$I_{CC}$	Quiescent Supply Current	1.8 to 5.5		1		10	$\mu A$	$V_{IN} = 5.5V, GND$		

AC Electrical Characteristics										
Symbol	Parameter	V <sub>CC</sub> (V)	T <sub>A</sub> = +25°C			T <sub>A</sub> = -40°C to +85°C		Units	Conditions	Figure Number
			Min	Typ	Max	Min	Max			
t <sub>PLH</sub> t <sub>PHL</sub>	Propagation Delay A to Y <sub>0</sub> or Y <sub>1</sub>	1.8 ± 0.15	2.0	6.3	10.1	2.0	10.5	ns	C <sub>L</sub> = 15 pF, R <sub>D</sub> = 1 MΩ S1 = OPEN	Figures 1, 3
		2.5 ± 0.2	1.0	3.6	5.7	1.0	6.0			
		3.3 ± 0.3	0.8	2.7	4.0	0.8	4.3			
		5.0 ± 0.5	0.5	2.0	3.1	0.5	3.3			
t <sub>PLH</sub> t <sub>PHL</sub>	Propagation Delay A to Y <sub>0</sub> or Y <sub>1</sub>	3.3 ± 0.3	1.2	3.4	4.9	1.2	5.4	ns	C <sub>L</sub> = 50 pF, R <sub>L</sub> = 500Ω S1 = OPEN	Figures 1, 3
		5.0 ± 0.5	0.8	2.5	3.9	0.8	4.2			
t <sub>PZL</sub> t <sub>PZH</sub>	Output Enable Time	1.8 ± 0.15	3.0	6.9	12.0	3.0	12.5	ns	C <sub>L</sub> = 50 pF R <sub>D</sub> , R <sub>U</sub> = 500Ω S1 = GND for t <sub>PZH</sub> S1 = V <sub>IN</sub> for t <sub>PZL</sub> V <sub>I</sub> = 2 x V <sub>CC</sub>	Figures 1, 3
		2.5 ± 0.2	1.8	4.2	6.8	1.8	7.3			
		3.3 ± 0.3	1.2	3.2	5.0	1.2	5.5			
		5.0 ± 0.5	0.8	2.5	4.0	0.8	4.3			
t <sub>PLZ</sub> t <sub>PHZ</sub>	Output Disable Time	1.8 ± 0.15	2.5	6.0	10.0	2.5	10.5	ns	C <sub>L</sub> = 50 pF R <sub>D</sub> , R <sub>U</sub> = 500Ω S1 = GND for t <sub>PHZ</sub> S1 = V <sub>IN</sub> for t <sub>PLZ</sub> V <sub>I</sub> = 2 x V <sub>CC</sub>	Figures 1, 3
		2.5 ± 0.2	1.5	4.0	6.8	1.5	7.1			
		3.3 ± 0.3	0.8	2.9	4.9	0.8	5.3			
		5.0 ± 0.5	0.3	1.8	3.5	0.3	3.7			
C <sub>IN</sub>	Input Capacitance	OPEN		2.5				pF		
C <sub>OUT</sub>	Output Capacitance	3.3V		4.0						
C <sub>PD</sub>	Power Dissipation Capacitance	3.3 5.0		16 19.5				pF	(Note 2)	Figure 2

**Note 2:** C<sub>PD</sub> is defined as the value of the internal equivalent capacitance which is derived from dynamic operating current consumption (I<sub>CCD</sub>) at no output loading and operating at 50% duty cycle. (See Figure 2.) C<sub>PD</sub> is related to I<sub>CCD</sub> dynamic operating current by the expression:  
I<sub>CCD</sub> = (C<sub>PD</sub>)(V<sub>CC</sub>)(f<sub>IN</sub>) + (I<sub>CC</sub>static).

## AC Loading and Waveforms

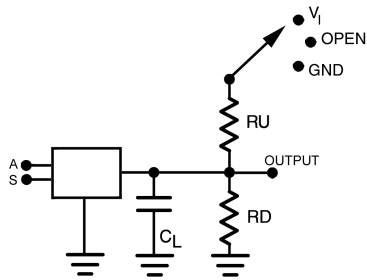

$C_L$  includes load and stray capacitance  
 Input PRR = 1.0 MHz;  $t_{W} = 500$  ns

**FIGURE 1. AC Test Circuit**



Input = AC Waveform;  $t_r = t_f = 1.8$  ns  
 PRR = 10 MHz; Duty Cycle = 50%  
 S Input = GND or  $V_{CC}$

**FIGURE 2.  $I_{CCD}$  Test Circuit**

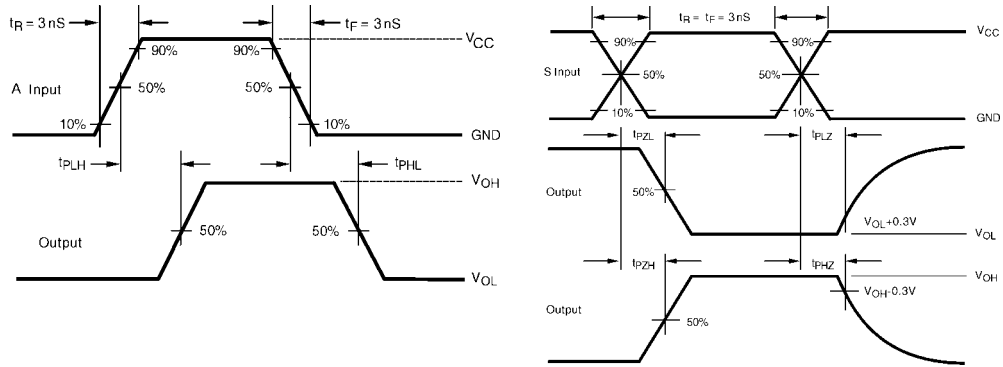

**FIGURE 3. AC Waveforms**

## Tape and Reel Specification

### TAPE FORMAT for SC70

Package Designator	Tape Section	Number Cavities	Cavity Status	Cover Tape Status
P6X	Leader (Start End)	125 (typ)	Empty	Sealed
	Carrier	3000	Filled	Sealed
	Trailer (Hub End)	75 (typ)	Empty	Sealed

### TAPE DIMENSIONS inches (millimeters)

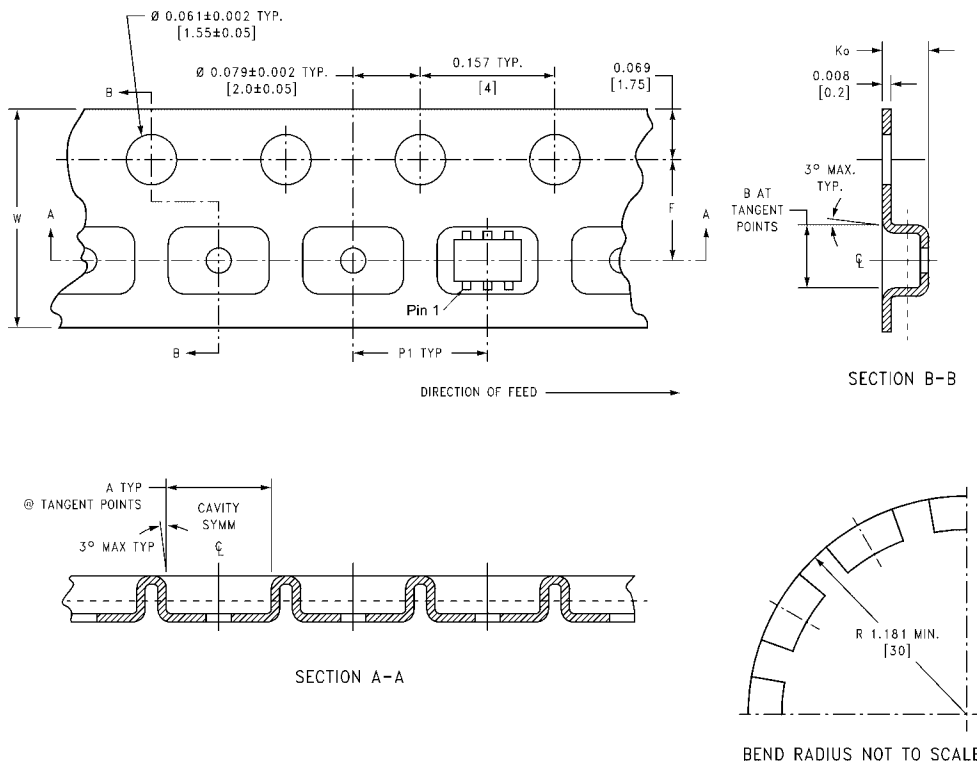

Package	Tape Size	DIM A	DIM B	DIM F	DIM $K_0$	DIM P1	DIM W
SC70-6	8 mm	0.093 (2.35)	0.096 (2.45)	$0.138 \pm 0.004$ ( $3.5 \pm 0.10$ )	$0.053 \pm 0.004$ ( $1.35 \pm 0.10$ )	0.157 (4)	$0.315 \pm 0.004$ ( $8 \pm 0.1$ )

NC7SZ18

**Tape and Reel Specification** (Continued)

**TAPE FORMAT for MicroPak**

Package Designator	Tape Section	Number Cavities	Cavity Status	Cover Tape Status
L6X	Leader (Start End)	125 (typ)	Empty	Sealed
	Carrier	3000	Filled	Sealed
	Trailer (Hub End)	75 (typ)	Empty	Sealed

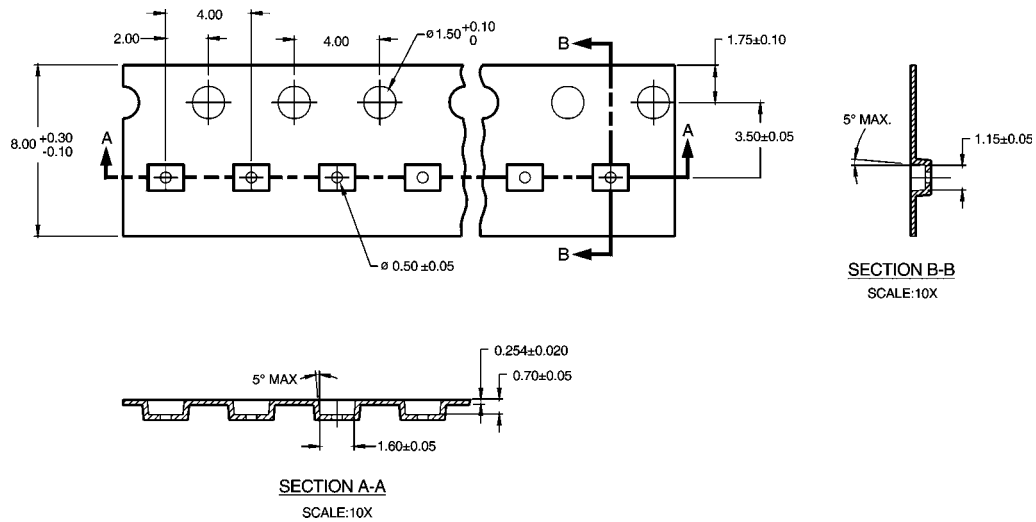

**REEL DIMENSIONS** inches (millimeters)

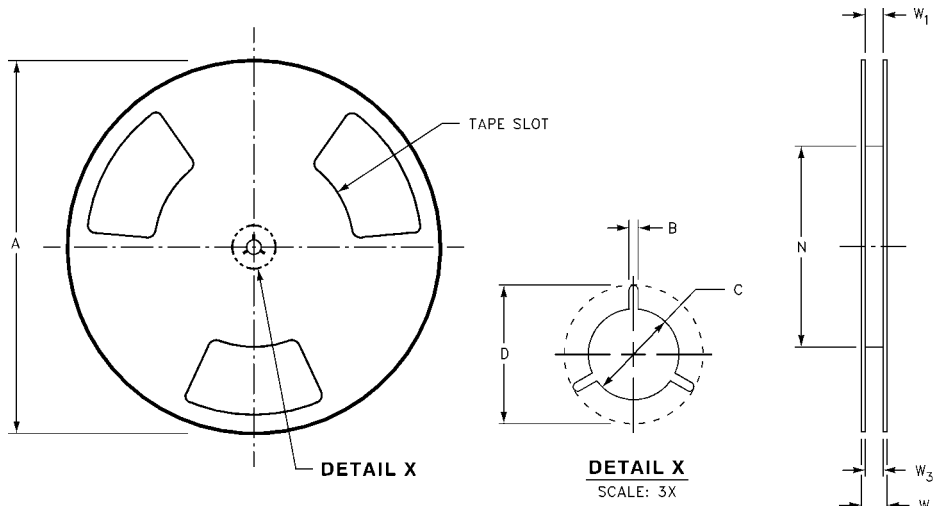

Tape Size	A	B	C	D	N	W1	W2	W3
8 mm	7.0 (177.8)	0.059 (1.50)	0.512 (13.00)	0.795 (20.20)	2.165 (55.00)	0.331 + 0.059/-0.000 (8.40 + 1.50/-0.00)	0.567 (14.40)	W1 + 0.078/-0.039 (W1 + 2.00/-1.00)

**Physical Dimensions** inches (millimeters) unless otherwise noted

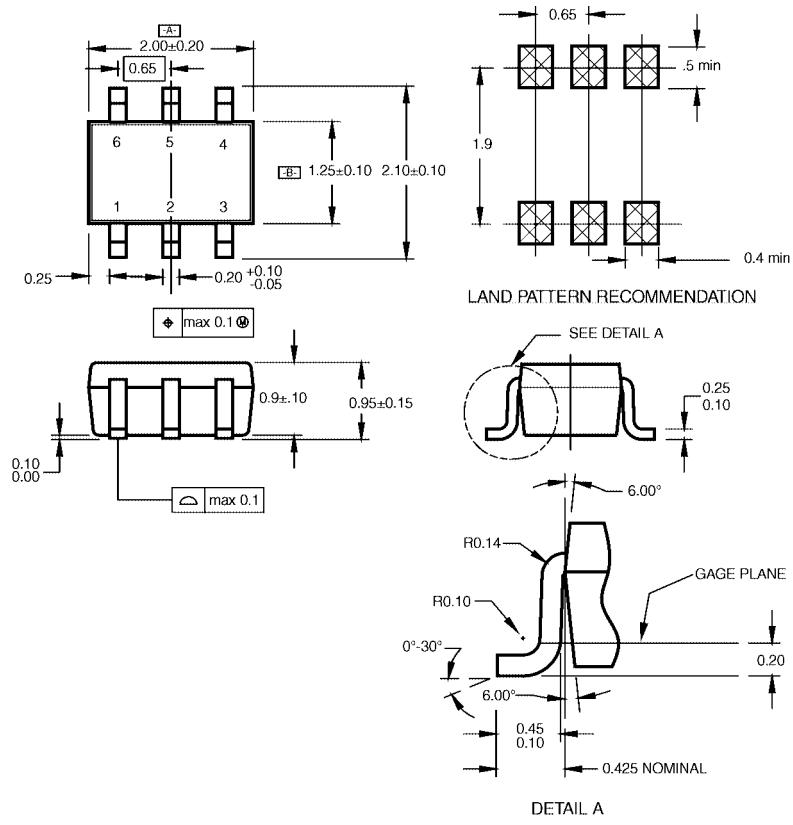

- NOTES:
- A. CONFORMS TO EIAJ REGISTERED OUTLINE DRAWING SC88.
  - B. DIMENSIONS DO NOT INCLUDE BURRS OR MOLD FLASH.
  - C. DIMENSIONS ARE IN MILLIMETERS.

MAA06ARevC

**6-Lead SC70, EIAJ SC88, 1.25mm Wide  
Package Number MAA06A**

**Physical Dimensions** inches (millimeters) unless otherwise noted (Continued)

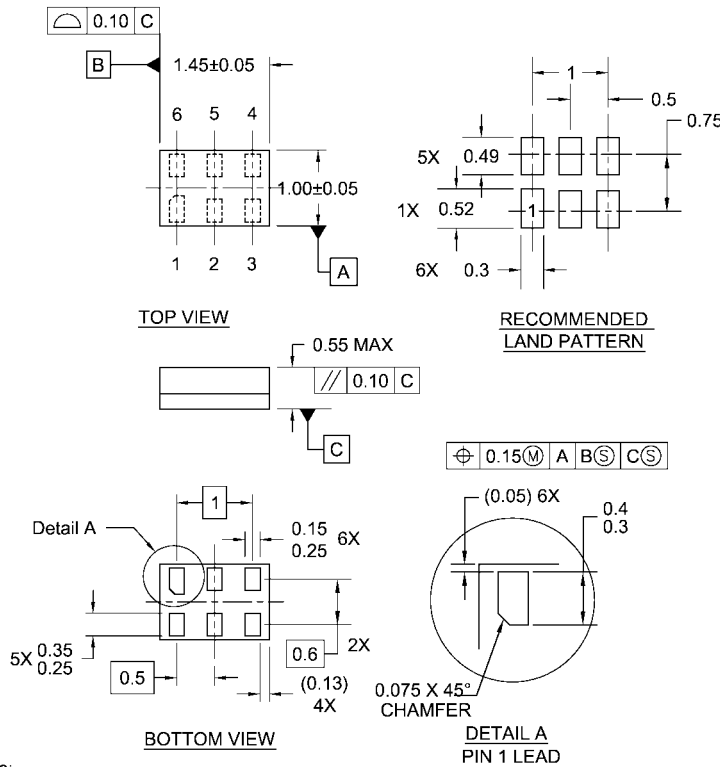

**Notes:**

1. JEDEC PACKAGE REGISTRATION IS ANTICIPATED
2. DIMENSIONS ARE IN MILLIMETERS
3. DRAWING CONFORMS TO ASME Y14.5M-1994

MAC06ARevB

**6-Lead MicroPak, 1.0mm Wide  
Package Number MAC06A**

Fairchild does not assume any responsibility for use of any circuitry described, no circuit patent licenses are implied and Fairchild reserves the right at any time without notice to change said circuitry and specifications.

**LIFE SUPPORT POLICY**

FAIRCHILD'S PRODUCTS ARE NOT AUTHORIZED FOR USE AS CRITICAL COMPONENTS IN LIFE SUPPORT DEVICES OR SYSTEMS WITHOUT THE EXPRESS WRITTEN APPROVAL OF THE PRESIDENT OF FAIRCHILD SEMICONDUCTOR CORPORATION. As used herein:

1. Life support devices or systems are devices or systems which, (a) are intended for surgical implant into the body, or (b) support or sustain life, and (c) whose failure to perform when properly used in accordance with instructions for use provided in the labeling, can be reasonably expected to result in a significant injury to the user.
2. A critical component in any component of a life support device or system whose failure to perform can be reasonably expected to cause the failure of the life support device or system, or to affect its safety or effectiveness.

[www.fairchildsemi.com](http://www.fairchildsemi.com)