

## PACKAGE DIMENSIONS

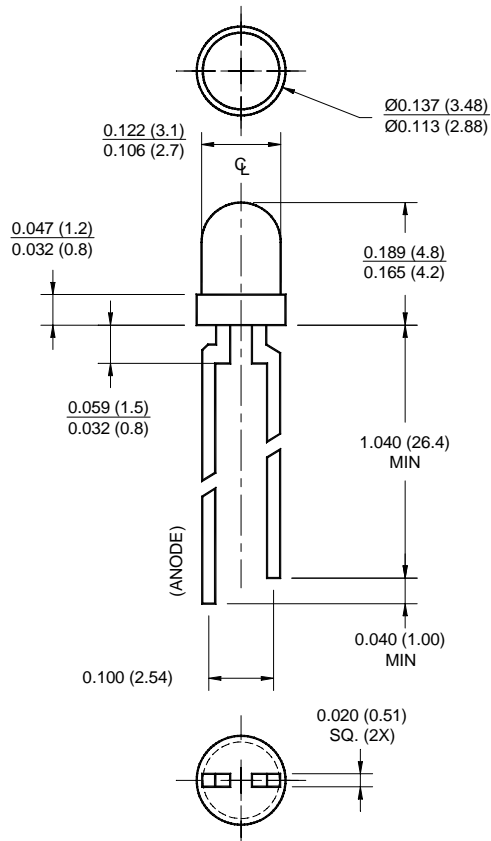

### NOTES:

1. Dimensions for all drawings are in inches (mm).
2. Lead spacing is measured where the leads emerge from the package.
3. Protruded resin under the flange is 1.5 mm (0.059") max.

**SUPER BLUE (WATER CLEAR)**  
**SUPER BLUE (BLUE DIFFUSED)**

**MV5B60**  
**MV5B640**

## FEATURES

- Low drive current
- Solid state reliability
- Water clear or blue diffused optics
- Standard 100 mil. lead spacing

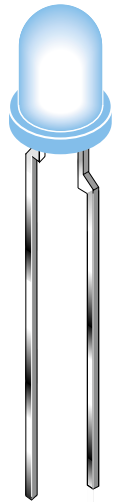

## DESCRIPTION

These T-100 super bright blue LEDs have a moderate viewing angle of 35° or 45° for concentrated light output. The blue diode chip is constructed with GaN/SiC technology and emits a peak wavelength of 430 nm.

## ABSOLUTE MAXIMUM RATINGS (T<sub>A</sub> = 25°C unless otherwise specified)

Parameter	Symbol	Rating	Unit
Operating Temperature	T <sub>OPR</sub>	-40 to +100	°C
Storage Temperature	T <sub>STG</sub>	-40 to +100	°C
Lead Soldering Time	T <sub>SOL</sub>	260 for 5 sec	°C
Continuous Forward Current	I <sub>F</sub>	30	mA
Peak Forward Current (f = 1.0 KHz, Duty Factor = 1/10)	I <sub>F</sub>	100	mA
Reverse Voltage (I <sub>R</sub> = 10 µA)	V <sub>R</sub>	5	V
Power Dissipation	P <sub>D</sub>	120	mW

<b>SUPER BLUE (WATER CLEAR)</b>	<b>MV5B60</b>
<b>SUPER BLUE (BLUE DIFFUSED)</b>	<b>MV5B640</b>

<b>ELECTRICAL / OPTICAL CHARACTERISTICS</b> ( $T_A = 25^\circ\text{C}$ )			
Part Number	MV5B60	MV5B640	Condition
Luminous Intensity (mcd)			$I_F = 20\text{ mA}$
Minimum	100	60	
Typical	150	100	
Forward Voltage (V)			$I_F = 20\text{ mA}$
Maximum	4.5	4.5	
Typical	3.8	3.8	
Peak Wavelength (nm)	430	430	$I_F = 20\text{ mA}$
Spectral Line Half Width (nm)	65	65	$I_F = 20\text{ mA}$
Viewing Angle ( $^\circ$ )	35	45	$I_F = 20\text{ mA}$

## TYPICAL PERFORMANCE CURVES

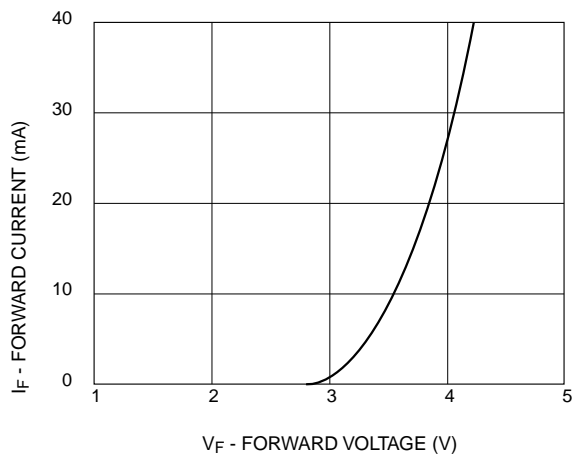

**Fig.1 Forward Current vs. Forward Voltage**

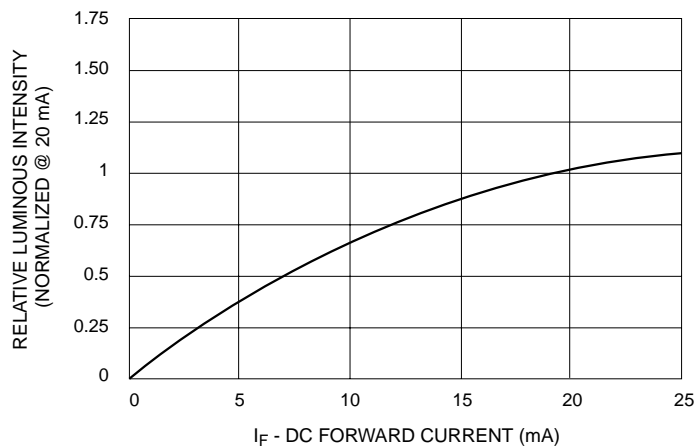

**Fig.2 Relative Luminous Intensity vs. DC Forward Current**

SUPER BLUE (WATER CLEAR)	MV5B60
SUPER BLUE (BLUE DIFFUSED)	MV5B640

## TYPICAL PERFORMANCE CURVES

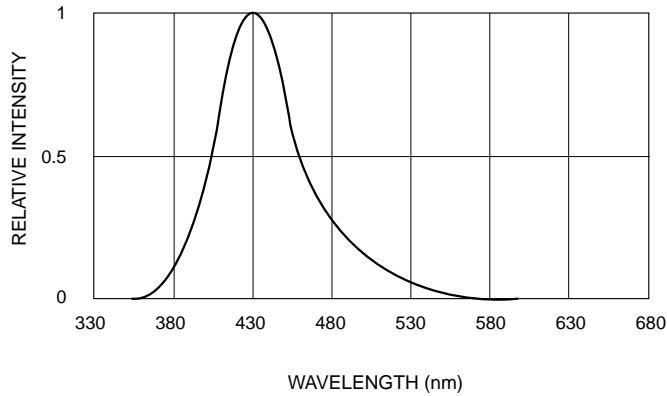

**Fig.3 Relative Intensity vs. Peak Wavelength**

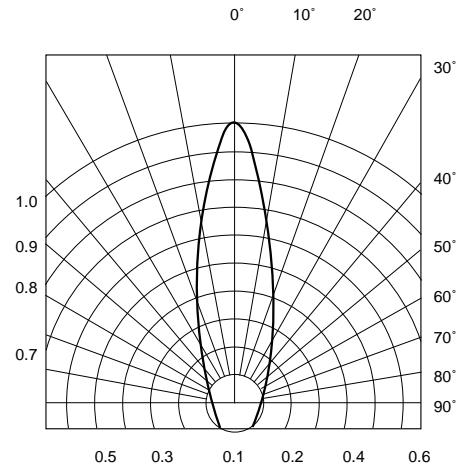

**Fig. 4a Radiation Diagram for MV5B60**

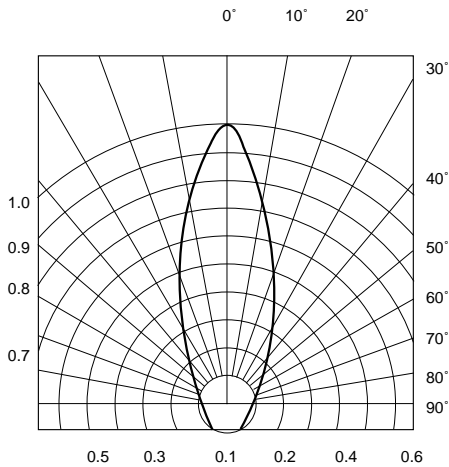

**Fig. 4b Radiation Diagram for MV5B640**

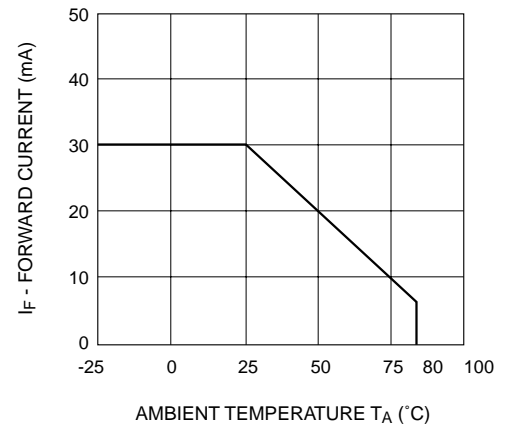

**Fig.5 Current Derating Curve**