

UTC M3355 LINEAR INTEGRATED CIRCUIT

2-INPUT SINGLE VIDEO SWITCH

DESCRIPTION

The UTC M3355 is 2-input signal video switch selecting one of two video or audio signals. Its operating voltage is 4.75 to 13V and bandwidth is 10MHz. Crosstalk is 70dB (at 4.43MHz). It is applied to both NTSC and PAL VTR.

FEATURES

- *Operating Voltage: +4.75V ~ +13V
- *2 Input-1 Output
- *Crosstalk 70dB (at 4.43MHz)

APPLICATION

*VCR, Video Camera AV -TV, Video Disc Player, Audio

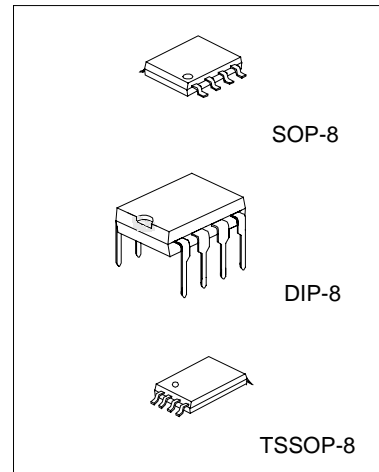

*Pb-free plating product number: M3355L

PIN CONFIGURATION

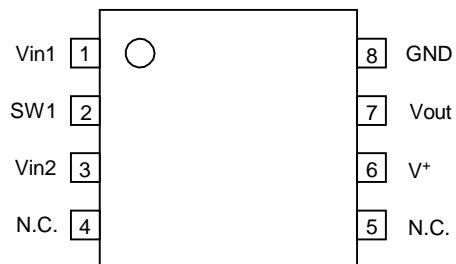

UTC M3355 LINEAR INTEGRATED CIRCUIT

EQUIVALENT CIRCUIT

PIN NO.	PIN NAME	INSIDE EQUIVALENT CIRCUIT	PIN NO.	PIN NAME	INSIDE EQUIVALENT CIRCUIT
1	V _{IN1}		5	NC	_____
2	SW1		6	V ⁺	_____
3	V _{IN2}		7	V _{OUT}	
4	NC	_____	8	GND	_____

UTC M3355

LINEAR INTEGRATED CIRCUIT

BLOCK DIAGRAM

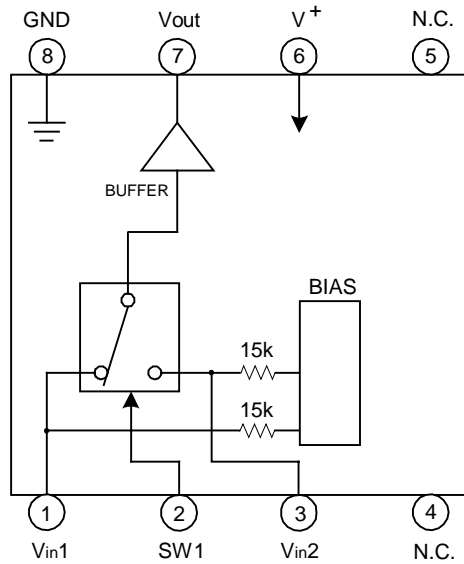

ABSOLUTE MAXIMUM RATINGS (Ta=25)

PARAMETER	SYMBOL	RATINGS	UNIT
Supply Voltage	V ⁺	15	V
Power Dissipation	P _d	DIP-8 SOP-8 SSOP-8	mW
Operating Temperature Range	T _{opr}	-20 ~ +75	°C
Storage Temperature Range	T _{stg}	-40 ~ +125	°C

ELECTRICAL CHARACTERISTICS (V⁺=5V, Ta=25)

PARAMETER	SYMBOL	TEST CONDITIONS	MIN	TYP	MAX	UNIT
Operating Voltage	V ⁺		4.75		13.0	V
Operating Current	I _{cc}	S1=S2=S3=1		8.5	11.0	mA
Frequency Characteristic (1)	G ₁₁	V _i =2.5V _{pp} , V _o (20Hz)/V _o (100kHz)		0	± 1.0	dB
Frequency Characteristic (2)	G ₁₂	V _i =2.0V _{pp} , V _o (10MHz)/V _o (100kHz)		0	± 1.0	dB
Voltage Gain	G _v	V _i =2.5V _{pp} , 100kHz, V _o /V _i	-0.5	0		dB
Total Harmonic Distortion	THD	V _i =2.5V _{pp} , 1kHz		0.01		%
Differential Gain	DG	V _i =2V _{pp} standard staircase signal		0		%
Differential Phase	DP	V _i =2V _{pp} standard staircase signal		0		deg
Output Offset Voltage	V _{off}	S1=S2=1, S3=1 2, V _o voltage change		0	± 15	mV
Crosstalk	CT	(S1=S3=1, S2=2) and (S1=S3=2, S2=1) V _i =2.0V _{p-p} , 4.43MHz, V _o /V _i		-70		dB
Switch Change Voltage	V _{CH}	Garanteed voltage of all switch on	2.4			V
	V _{CL}	Garanteed voltage of all switch off			0.8	
Input Impedance	R _i			15		k

UTC M3355 LINEAR INTEGRATED CIRCUIT

Output impedance	R_o		10		
------------------	-------	--	----	--	--

CONTROL SIGNAL-OUTPUT SIGNAL

SW1	OUTPUT SIGNAL
L	Vin 1
H	Vin 2

TEST CIRCUIT

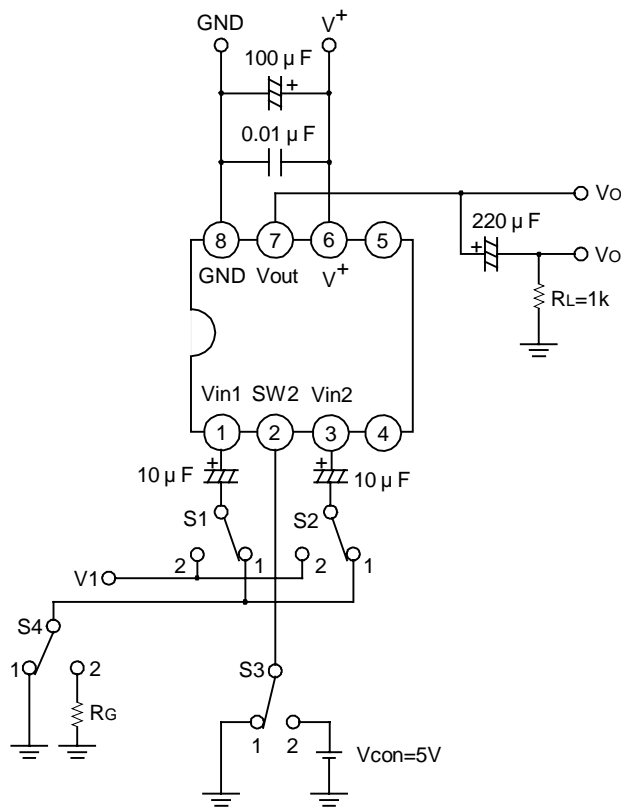

DC Voltage Each Terminal (Typ.on Test Circuit $T_a=25$)

Terminal Name	VIN1	SW1	VIN2	V+	VOUT	GND
DC Voltage	$\frac{3}{5}V^+$	—	$\frac{3}{5}V^+$	—	$\frac{3}{5}V^+ - 0.7$	—

UTC M3355 LINEAR INTEGRATED CIRCUIT

APPLICATION

Oscillation Prevention on light loading conditions
Recommended under circuit

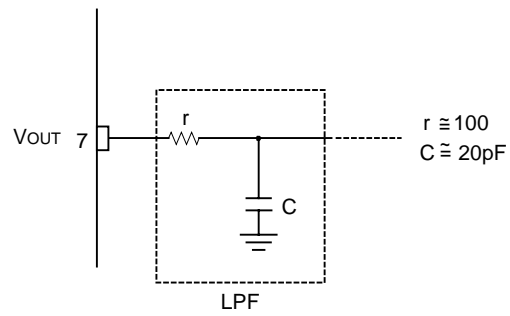

This IC requires 0.1 μ F capacitor between INPUT and GND for bias type input at mute mode

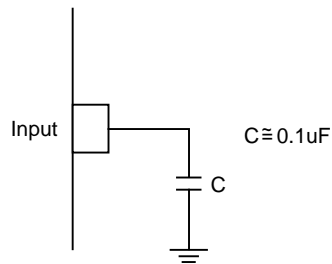

UTC M3355 LINEAR INTEGRATED CIRCUIT

TYPICAL CHARACTERISTICS

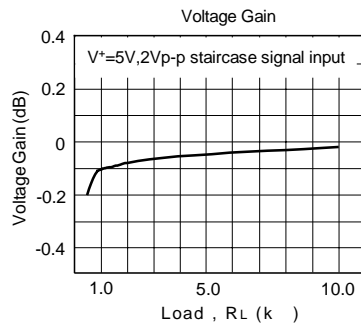
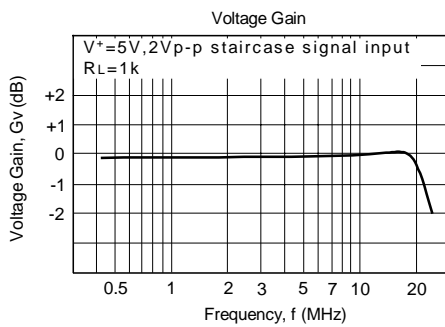
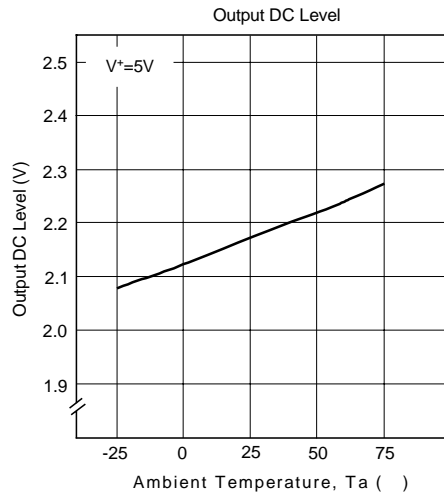
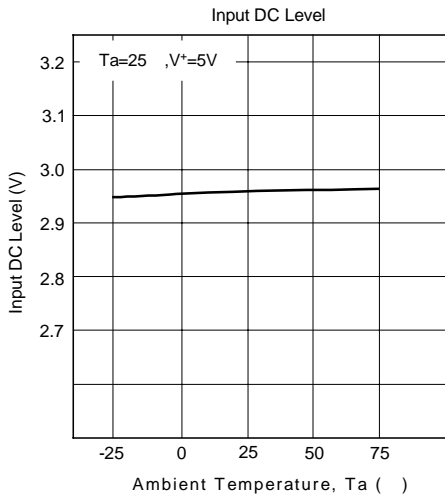
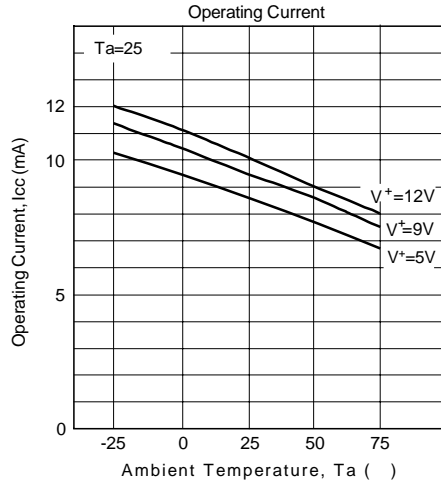
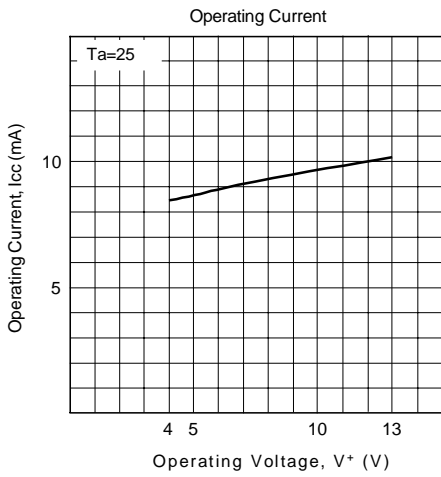

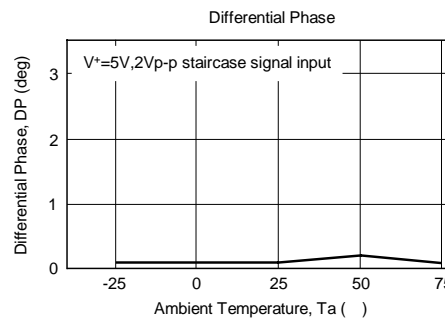
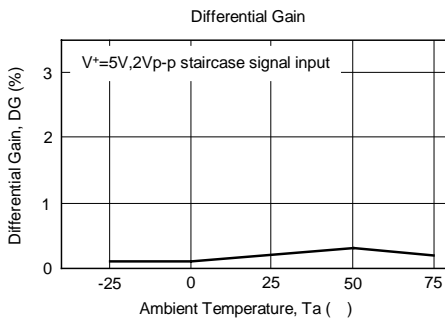
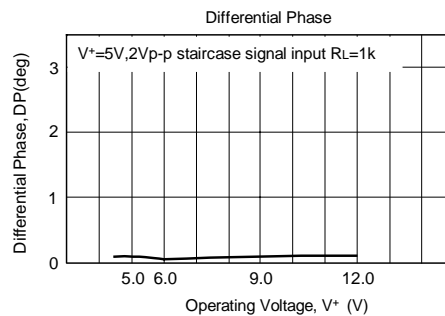
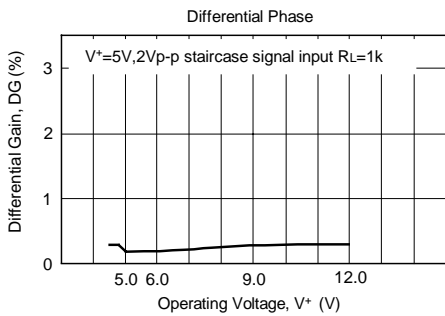
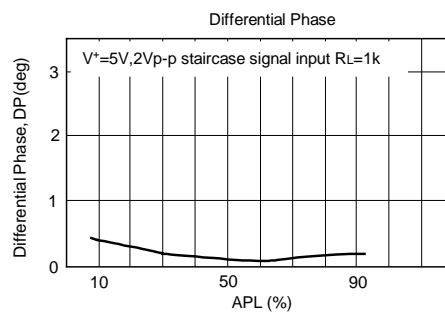
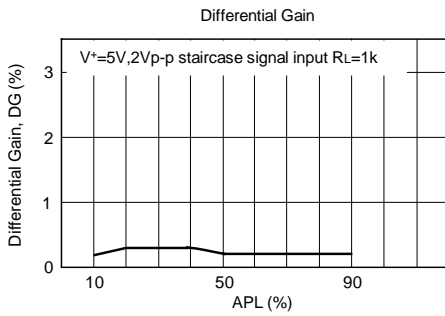
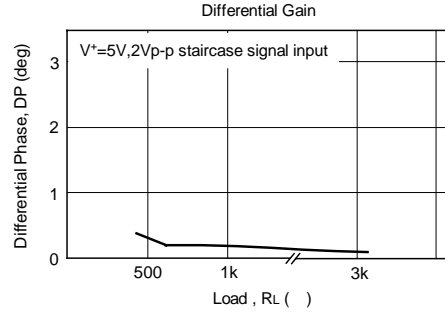
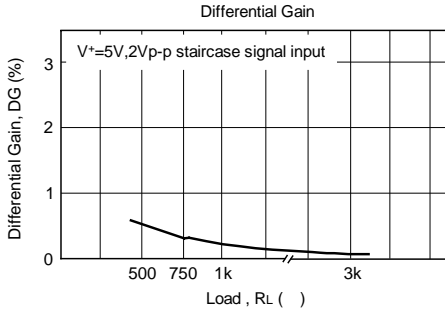

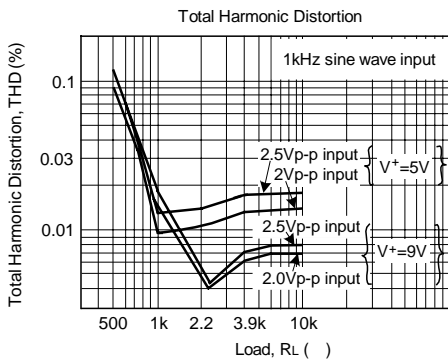
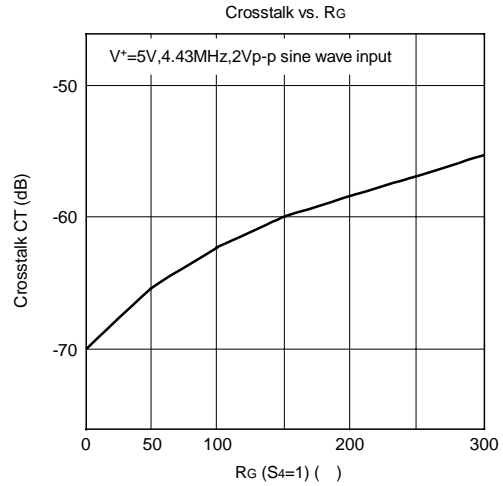
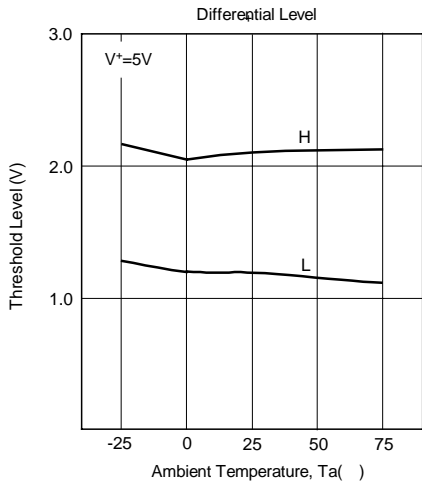

UTC assumes no responsibility for equipment failures that result from using products at values that exceed, even momentarily, rated values (such as maximum ratings, operating condition ranges, or other parameters) listed in products specifications of any and all UTC products described or contained herein. UTC products are not designed for use in life support appliances, devices or systems where malfunction of these products can be reasonably expected to result in personal injury. Reproduction in whole or in part is prohibited without the prior written consent of the copyright owner. The information presented in this document does not form part of any quotation or contract, is believed to be accurate and reliable and may be changed without notice.