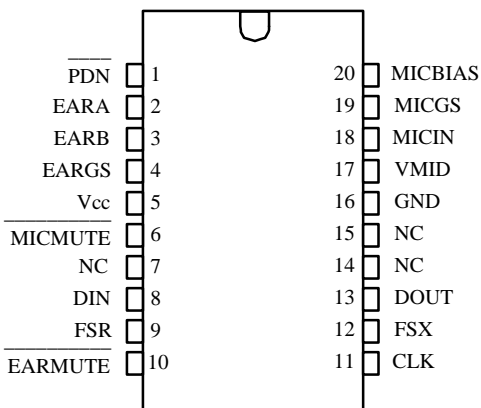
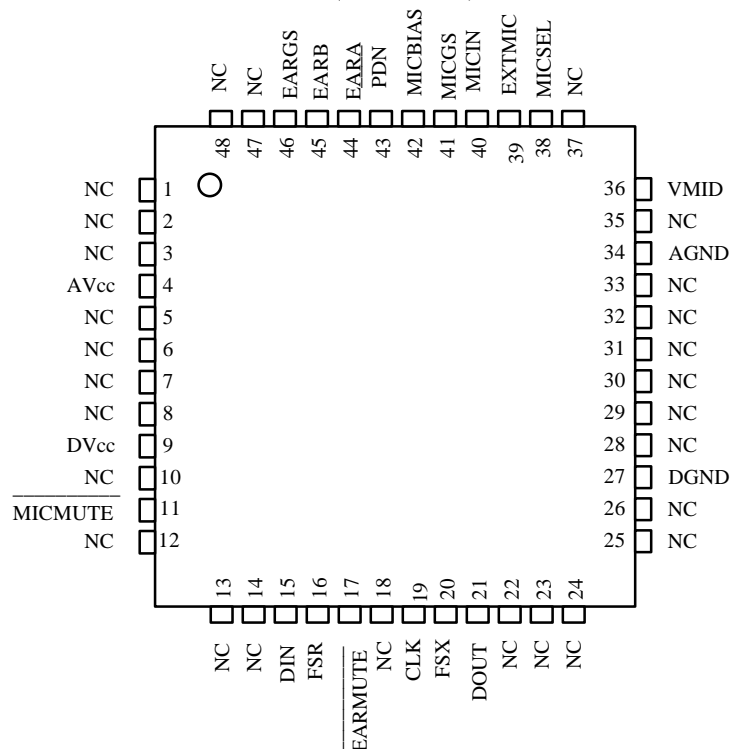

## GM0936TQ

## Voice-Band Audio CODEC for CDMA

## Features

- Single 3-V operation
- Low power consumption
  - Operating mode .... 20mW Typ
  - Power-down mode ... 1mW Typ
- Combined A/D, D/A, and Filters
- Electret microphone bias reference voltage available
- Compatible with all digital signal processors (DSPs)
- Programmable volume control
- 300 Hz - 3.6 kHz Passband with Specified Master clock
- Designed for standard 2.048MHz master clock for U.S. Analog, U.S. Digital, CT2, DECT, GSM, and PCS Standards for Hand-held Battery-Powered Telephones
- On-chip voltage references
- Package Type : 48 LQFP, 20 DIP, 20 SOP

20 DIP/SOP  
(TOP VIEW)48 LQFP  
(TOP VIEW)

## Description

The GM0936TQ contains A/D and D/A conversion functions integrated on a single chip, and utilizes the sigma-delta modulation technique to achieve high resolution data conversion and low power consumption. The GM0936TQ is an ideal analog front end device for high performance voice-band communication systems. Cellular telephone systems are targeted in particular; however, these integrated circuits can function in other systems including digital audio, telecommunications, and data acquisition.

The transmit section is designed to interface directly with an electret microphone element. One of two microphone input signals, MICIN and EXTMIC, is selected by MICSEL. If MICSEL is floated or Low, then MICIN is selected, and if MICSEL is high, then EXTMIC is selected. The microphone input signal (MICIN and EXTMIC) is buffered, first-order low-pass filtered, and amplified with provision for setting the amplifier gain to accommodate a range of signal input levels. The amplified signal is 1bit-modulated by second-order sigma-delta modulator. The modulated signal is then applied to the input of high-performance FIR-type digital decimation filters with frequency response equalization. The resulting data is then clocked out of DOUT as a serial data stream.

The receive section takes a frame of serial data on DIN and converts it to analog through high-performance FIR-type digital interpolation filter together with frequency response equalization, second-order digital sigma-delta modulator, and analog reconstruction filters.

On-chip voltage reference ensures a highly integrated solution and all internal voltage references are generated. An internal reference voltage, VMID, is used to develop the midlevel virtual ground for all the amplifier circuits and the microphone bias circuit. Another reference voltage, MICBIAS, can supply bias current for the microphone.

Serial DSP interfaces for transmit and receive paths support directly industry standard DSP processors.

The GM0936TQ devices are characterized for operation from -20 to 70; É



## Pin Description

### ANALOG SIGNALS

TERMINAL NAME	LQFP	SOP&DIP	I/O	DESCRIPTION
AGND	34	16		Analog Ground
AVcc	4	5		Analog Power (3V)
EARA	44	2	O	Earphone output
EARB	45	3	O	Side-tone output
EARGS	46	4	I	Side-tone input
EARMUTE_	17	10	I	Earphone output mute control signal
MICBIAS	42	20	O	Microphone bias
MICGS	41	19	O	Output of the internal microphone amplifier
MICIN	40	18	I	Microphone input
MICMUTE_	11	6	I	Microphone input mute
VMID	36	17	O	Bias voltage reference. A pair of external, low-leakage, high-frequency capacitors (1 $\mu$ F and 470 pF) should be connected between VMID and ground for filtering
ETMIC	39	N/A	I	Hand-free MIC-IN
MICSEL	38	N/A	I	MIC-IN selection input. When float or low, MICSEL selects MICIN. When high, MICSEL selects EXTMIC.

---

## Pin Description

### DIGITAL SIGNALS

TERMINAL NAME	LOFP	SOP&DIP	I/O	DESCRIPTION
CLK	19	11	I	Clock input (2.048 MHz)
DGND	27	16		Digital ground
DIN	15	8	I	Receive data input
DOUT	21	13	O	Transmit data output
DVcc	9	5		Digital power (3 V)
FSR	16	9	I	Frame-synchronization clock input for receive channel
FSX	20	12	I	Frame-synchronization clock input for receive channel
PDN	43	1	I	Power-down input, Active Low
NC	1,2,3, 5,6,7, 8,10, 12,13, 14,18, 22,23, 24,25, 26,28, 29,30, 31,32, 33,35	7, 14, 15		No internal connection

## Electrical Characteristics

### Absolute Maximum Ratings over operating free-air temperature range

PARAMETER	SYMBOL	MIN	TYP	MAX	UNIT
Supply Voltage Range	$DV_{CC}, AV_{CC}$	- 0.3		3.6	V
Digital Input Voltage Range	$V_{ind}$	- 0.3		3.6	V
Analog Input Voltage Range	$V_{ina}$	- 0.3		3.6	V

### Recommended Operating Conditions

PARAMETER	SYMBOL	MIN	TYP	MAX	UNIT
Supply Voltage	$DV_{CC}, AV_{CC}$	2.7	3.0	3.3	V
High-level Input Voltage	$V_{IH}$	2.2			V
Low-level Input Voltage	$V_{IL}$			0.8	V
Operating free-air Temperature	$T_A$	-20		70	°C

### Power Supply Characteristics, $f_{CLK} = 2.048$ MHz, outputs not loaded, $V_{CC}=3V$ , $T_A=25$ °C

PARAMETER	MIN	TYP	MAX	UNIT
Power Dissipation , Operating		18		mW
Power Dissipation , Power down		1		mW

### Digital Characteristics ( $T_A=25$ °C, $DV_{CC} = AV_{CC} = 3V$ )

PARAMETER	MIN	TYP	MAX	UNIT
Input Capacitance			10	pF
Input Leakage Current	- 10		10	µA
Low-level output Voltage ( $I_{OL} = 3.2mA$ )			0.4	V
High-level output Voltage ( $I_{OH} = -3.2mA$ )	2.4			V

### Microphone interface

PARAMETER	TEST CONDITIONS	MIN	TYP	MAX	UNIT
V <sub>IO</sub> Input offset voltage at MICIN	V <sub>I</sub> = 0 to 3 V			±5	mV
I <sub>IB</sub> Input bias current at MICIN				±200	nA
B <sub>1</sub> Unity-gain bandwidth, open loop at MICIN			1.5		MHz
A <sub>v</sub> Large-signal voltage amplification at MICGS			10000		V/V
I <sub>omax</sub> Maximum output current	VMID	3			μA
	MICBIAS(source only)	1			mA

### Speaker interface

PARAMETER	TEST CONDITIONS	MIN	TYP	MAX	UNIT
V <sub>O(PP)</sub> AC output voltage				3	V <sub>pp</sub>
I <sub>Omax</sub> Maximum output current	R <sub>L</sub> = 600 Ω			±1	mA
r <sub>o</sub> Output resistance at EARA, EARB			1		Ω
Gain change	EARMUTE low, max level when muted	-60			dB

**Analog Characteristics** ( $T_A=25^\circ\text{C}$ ;  $\dot{E} DV_{CC} = AV_{CC} = 3\text{V}$ ,  $f_s = 8\text{ kHz}$ )

## A/D Converter

PARAMETER	MIN	TYP	MAX	UNIT
Oversampling Ratio		128		
Resolution		13		bit
Dynamic Range		70		dB
S/(N+THD)	50	52		dB
Output Sample Rate		8		KHz
Maximum output current for MICBIAS	1			mA
Maximum output voltage for Microphone Amplifier	0.85		0.95	V <sub>pp</sub>

Transmit filter transfer over recommended ranges of supply voltage and free-air temperature, CLK=2.048 MHz, FSX=8 kHz

PARAMETER	TEST CONDITIONS	MIN	TYP	MAX	UNIT	
Gain relative to input signal at 1.02 kHz	Input amplifier set for unity gain, the output for 400mV <sub>pp</sub> signal at MICGS is 0dB	f <sub>MICIN</sub> = 50 Hz		0.76		dB
		f <sub>MICIN</sub> = 200 Hz		0.73		
		f <sub>MICIN</sub> = 300 Hz		0.67		
		f <sub>MICIN</sub> = 1 kHz		0		
		f <sub>MICIN</sub> = 2 kHz		-1.9		
		f <sub>MICIN</sub> = 3 kHz		-4.5		
		f <sub>MICIN</sub> = 3.3 kHz		-5.4		
		f <sub>MICIN</sub> = 3.8 kHz		-8.9		



Transmit idle channel noise and distortion, linear mode selected, over recommended ranges of supply voltage and free-air temperature (see Notes 1 and 2)

PARAMETER	TEST CONDITIONS	MIN	TYP	MAX	UNIT
Transmit noise	MICIN connected to MICGS through a 22 k $\Omega$ resistor		178		$\mu$ V <sub>rms</sub>
Gain relative to input signal at 1.02 kHz	MICIN to DOUT at 0 dBm0		53		dB
	MICIN to DOUT at -3 dBm0		52.3		
	MICIN to DOUT at -6 dBm0		51.9		
	MICIN to DOUT at -9 dBm0		50.7		
	MICIN to DOUT at -12 dBm0		49.0		

Notes: 1. The input amplifier is set for inverting unity gain.

2. Transmit noise, linear mode: 200  $\mu$ V<sub>rms</sub> is equivalent to -75 dB (referenced to device 0 dB level).

#### D/A Converter

PARAMETER	MIN	TYP	MAX	UNIT
Oversampling Ratio		128		
Resolution		13		bit
Dynamic Range		67		dB
S/(N+THD)	48	54		dB
Maximum output current ( $R_L = 600\ \Omega$ )			$\pm 1$	mA
Output Voltage Range	0.81		0.91	V <sub>pp</sub>

Receive distortion, linear mode selected, over recommended ranges of supply voltage and free-air temperature

PARAMETER	TEST CONDITIONS	MIN	TYP	MAX	UNIT
Receive signal-to-distortion ratio with sine-wave input	DIN to EARA at 0 dBm0		60		dB
	DIN to EARA at -3 dBm0		59.7		
	DIN to EARA at -6 dBm0		59.6		
	DIN to EARA at -9 dBm0		56.1		
	DIN to EARA at -12 dBm0		55.3		

---

Power supply rejection over recommended ranges of supply voltage and operating free-air temperature

PARAMETER	TEST CONDITIONS	MIN	TYP	MAX	UNIT
Supply voltage rejection, transmit channel	Idle channel, supply signal = 100mVrms f = 1 kHz (measured at DOUT)		-50		dB
Supply voltage rejection, receive channel	Idle channel, supply signal = 100mVrms f = 1 kHz (measured at EARA)		-50		dB

**Timing** ( $T_A=25$ ;  $V_{CC} = AV_{CC} = 3V$ )

PARAMETER	MIN	TYP	MAX	UNIT
CLK Frequency		2.048		MHz
Sampling Rate		8		KHz
DOUT Delay from CLK			35	ns
DIN Delay from CLK			35	ns

## Clock timing requirements

	MIN	NOM	MAX	UNIT
Duty cycle, CLK	45%	50%	55%	

## Transmit timing requirements

	MIN	MAX	UNIT
$t_{su}(FSX)$ Setup time, FSX high before CLK	20	468	ns
$t_h(FSX)$ Hold time, FSX high after CLK	20	468	ns

## Receive timing requirements

	MIN	MAX	UNIT
$t_{su}(FSR)$ Setup time, FSR high before CLK	20	468	ns
$t_h(FSR)$ Hold time, FSR high after CLK	20	468	ns
$t_{su}(DIN)$ Setup time, DIN high or low before CLK	20		ns
$t_h(DIN)$ Hold time, DIN high or low after CLK	20		ns

Timing Diagram

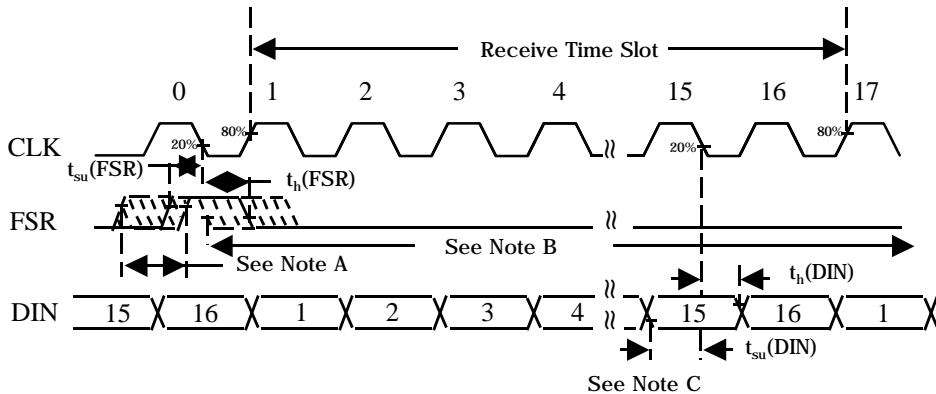

- NOTES: A. This window is allowed for FSR high.
- B. This window is allowed for FSR low.
- C. Transitions are measured at 50%.

Figure1. Receive Side Timing Diagram

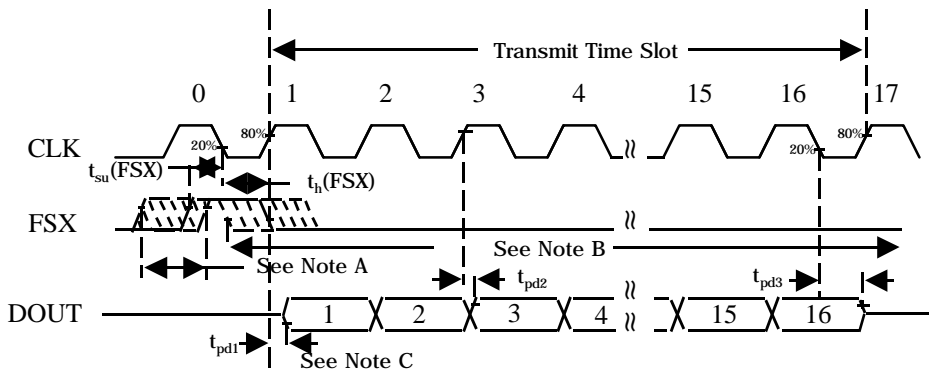

- NOTES: A. This window is allowed for FSX high.
- B. This window is allowed for FSX low.
- C. Transitions are measured at 50%.

Figure2. Transmit Side Timing Diagram

---

 PRINCIPLES OF OPERATION
**power-down operation**

To minimize power consumption, a power-down mode is provided.

For power down, an external low signal is applied to PDN. In the absence of a signal, PDN is internally pulled up to a high logic level and the device remains active. In the power-down mode, the average power consumption is reduced to 1mW.

**Timing**

FSX and FSR are inputs that set the sampling frequency. Data is transmitted on DOUT on the positive transitions of CLK following the rising edge of FSX. Data is received on DIN on the falling edges of CLK following FSR.

Table 1. Power- On and Power- Down Procedures

DEVICE STATUS	PROCEDURE	TYPICAL POWER CONSUMPTION	DIGITAL OUTPUT STATUS
Power on	$\overline{\text{PDN}} = \text{high}$ , FSX = pulses, FSR = pulses	20 mW	Digital outputs active
Power down	$\overline{\text{PDN}} = \text{low}$ , FSX,FSR =X	1 mW	DOUT in the high- impedance state

X = dont care

## PRINCIPLES OF OPERATION

### transmit operation

#### microphone input

The microphone input amplifier is designed specifically to interface to electret-type microphone elements, as shown in Figure 3. The VMID buffer circuit provides a voltage (MICBIAS) as a bias voltage to the electret microphone. The microphone amplifier output (MICGS) is used in conjunction with a feedback network and applied to the amplifier inverting input (MICIN) to set the amplifier gain. VMID appears at a terminal to provide a place to filter the VMID voltage.

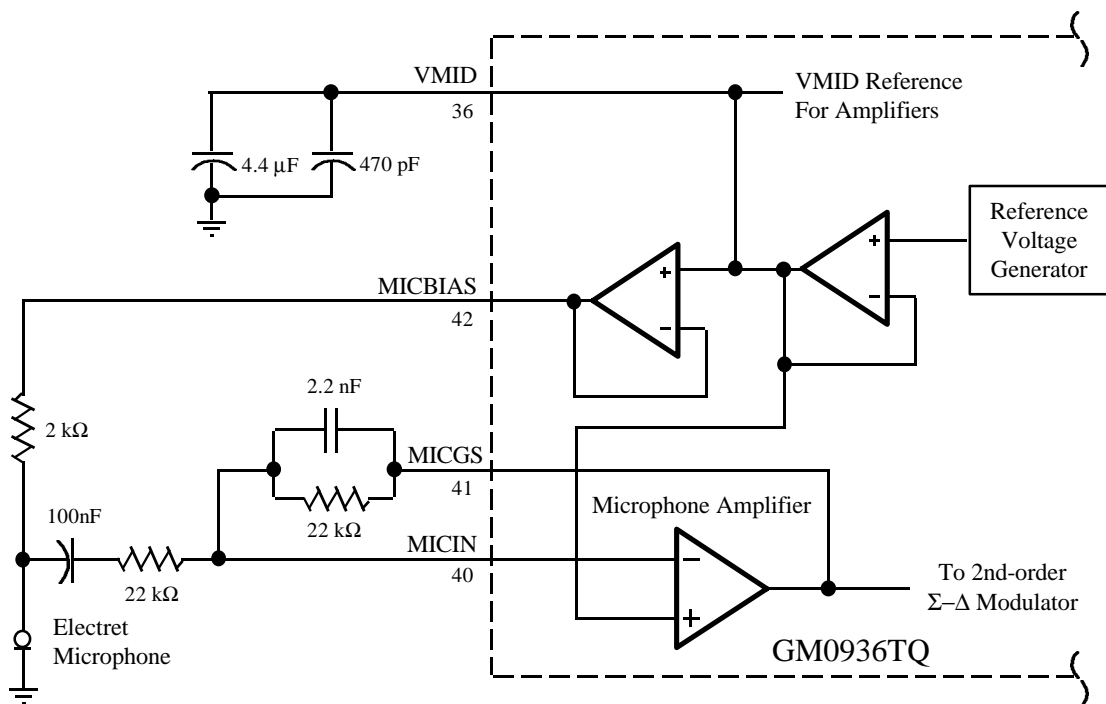

NOTE A: Terminal numbers shown are for the 48 LQFP package.

**Figure 3. Typical Microphone Interface**

#### microphone mute function

The MICMUTE input causes the digital circuitry to transmit all zero code on DOUT.

#### transmit filter

A low-pass antialiasing section is implemented by connecting a RC-pair externally between MICGS and MICIN. The RC-pair, together with the microphone amplifier, provides a single-pole low pass filter. The antialiased signal is 1bit-modulated by second-order sigma-delta modulator. The modulated signal is then applied to the input of high-performance FIR-type digital decimation filters with frequency response equalization.

---

## PRINCIPLES OF OPERATION

### encoding

The encoder performs an A/D conversion on a 2nd-order Sigma-Delta ( $\Sigma$ - $\Delta$ ) modulator using a switched-capacitor technology and high-performance FIR-type digital decimation filters with frequency response equalization. The resulting data is then clocked out of DOUT as a serial data.

### data word structure

The data word is 16 bits long. The first 13 bits comprises the audio data sample, and the last three bits form the volume control word in the receive direction (DIN) and are zero pad bits in the transmit direction (DOUT). The sign bit is transmitted first.

### receive operation

#### decoding

The serial data word is received at DIN on the first 13 clock cycles. The receive section converts a frame of sereal data to analog through high-performance FIR-type digital interpolation filter together with frequency response equalization, second-order digital sigma-delta modulator, and analog reconstruction filters.

#### receive buffer

The receive buffer contains the volume control.

#### earphone amplifier

The output can be used to drive a single-ended load with the output signal voltage centered around VMID. EARA in Figure 4 is the output pin for the decoded analog signal. EARB in the figure is used for sidetone signal output which is used internally. A resistor-capacitor pair attached to EARB is embedded to reduce the number of on-board components. See the next section for more information on sidetone generation.

## PRINCIPLES OF OPERATION

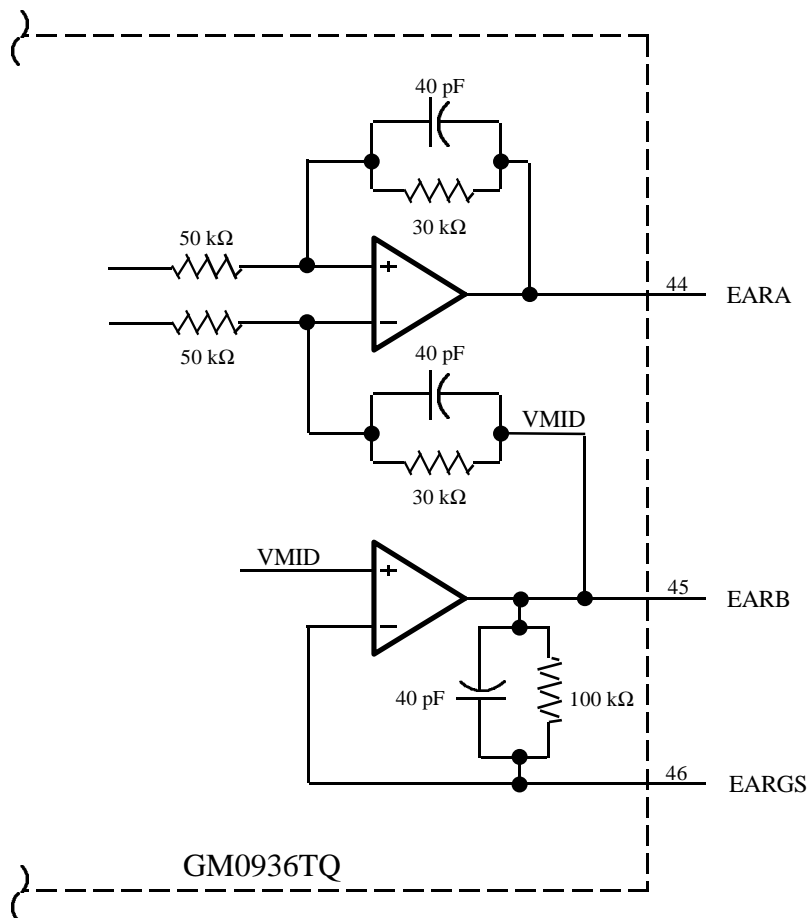

NOTE A: Terminal numbers shown are for the 48 LQFP package.

**Figure 4. Earphone Audio-Output Amplifier Configuration**

#### receive data format

In the decoding operation, 16 bits of data are received. The first 13 bits are the D/A code, and the remaining three bits from the volume control word (see Table 2). The volume control function is actually an attenuation control in which the first bit received is the most significant. The maximum volume occurs when all three volume control bits are zero. Eight levels of attenuation are selectable in 3-dB steps, giving a maximum attenuation of 21 dB when all bits are 1s. The volume control bits are not latched into the GM0936TQ and must be present in each received data word.





## APPLICATION INFORMATION

### output gain set and sidetone considerations

The single-ended outputs EARA and EARB are capable of driving output power level up to 1mW into load impedance of 1k $\Omega$  separately. The sidetone signal and the received signal can be summed by configuring external components like in Figure 5. The amount of sidetone mixing is controlled by the resistor connected between EARB and EARGS. If the resistance become greater, the amount of sidetone mixing increases.

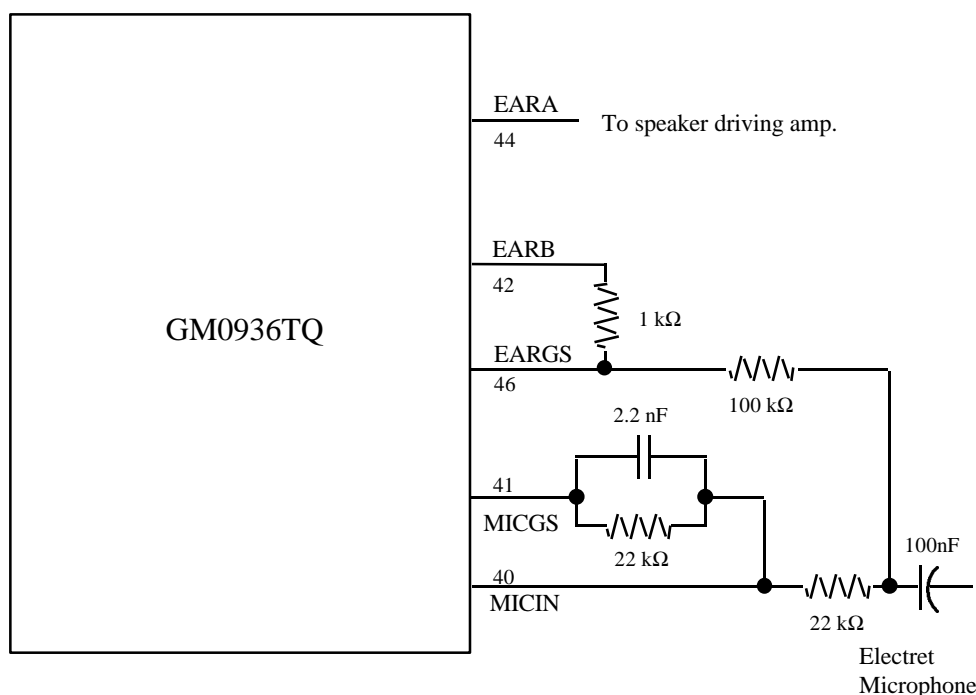

NOTE A: Terminal numbers shown are for the 48 TQFP package.

**Figure 5. Configuration for Gain-Setting and Sidetone**

### higher clock frequencies and sample rates

The GM0936TQ is designed to work with sample rates up to 16kHz where the frequency of the frame sync determines the sampling frequency. However, there is a fundamental requirement to maintain the ratio of the master clock frequency,  $f_{CLK}$ , to the frame sync frequency,  $f_{FSR}/f_{FSX}$ . This ratio for the GM0936TQ is 2.048 MHz/8 kHz, or 256 master clocks per frame sync. For example, to operate the GM0936TQ at a sampling rate of  $f_{FSR}$  and  $f_{FSX}$  equal to 16 kHz,  $f_{CLK}$  must be 256 times 16 kHz, or 4.096 MHz. If the GM0936TQ is operated above an 8-kHz sample rate, however, it is expected that the performance becomes somewhat degraded. Exact parameter specifications for rates up to 16-kHz sample rate are not specified at this time.

## MECHANICAL DATA

## PLASTIC SMALL-OUTLINE PACKAGE

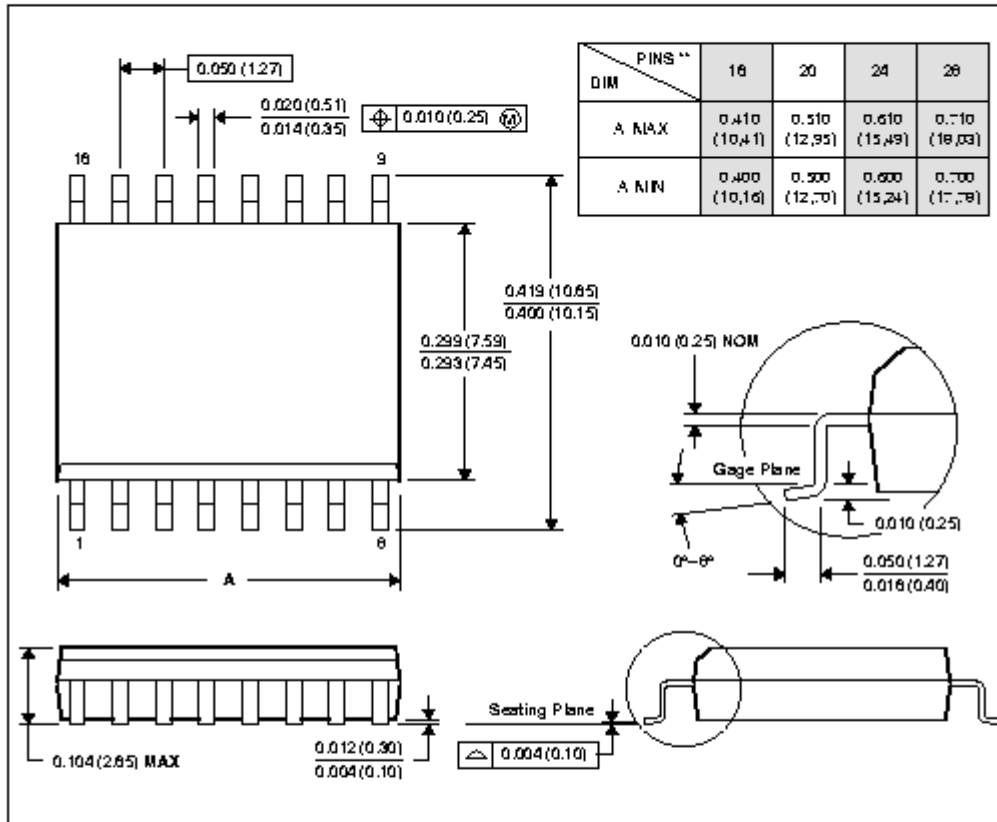

- NOTES: A. All linear dimensions are in inches (millimeters).  
 B. This drawing is subject to change without notice.  
 C. Body dimensions do not include mold flash or protrusion not to exceed 0.006 (0.15).  
 D. Falls within JEDECMS-013

## MECHANICAL DATA

## PLASTIC DUAL-IN-LINE PACKAGE

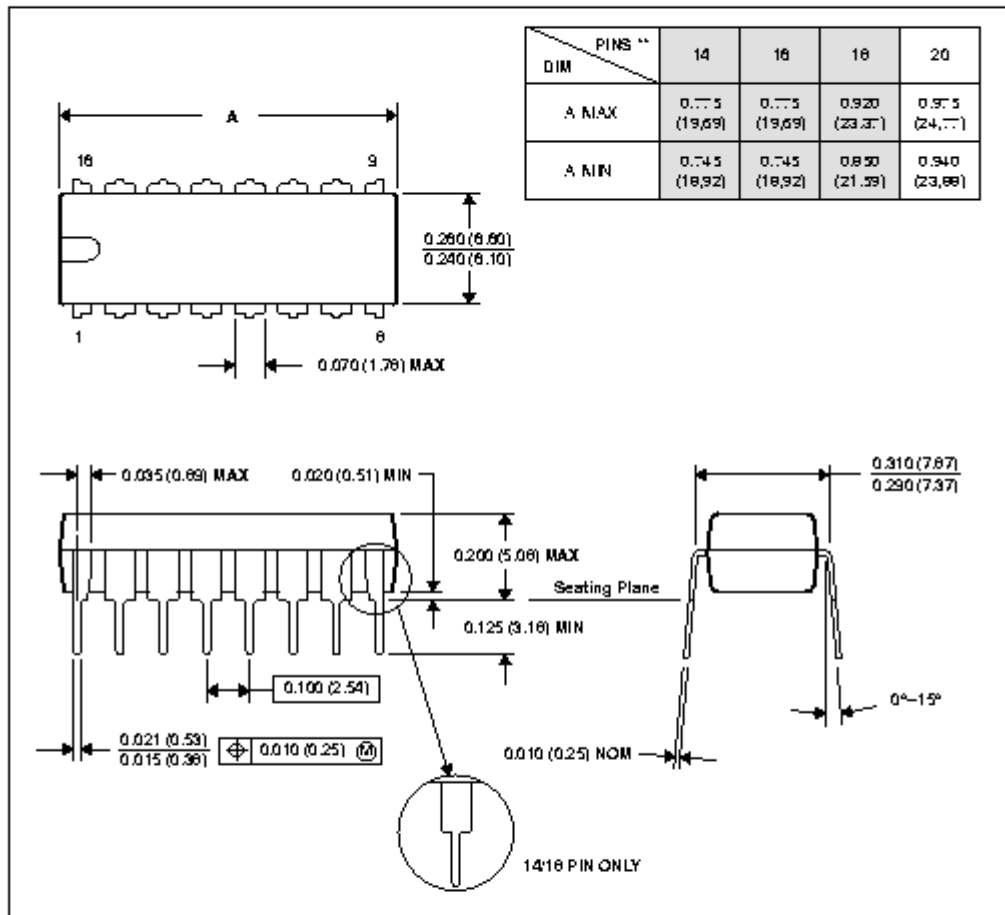

- NOTES: A. All linear dimensions are in inches (millimeters).  
 B. This drawing is subject to change without notice.  
 C. Falls within JEDEC MS-001 (20 pin package is shorter than MS-001.)

## MECHANICAL DATA

## PLASTIC QUAD FLATPACK

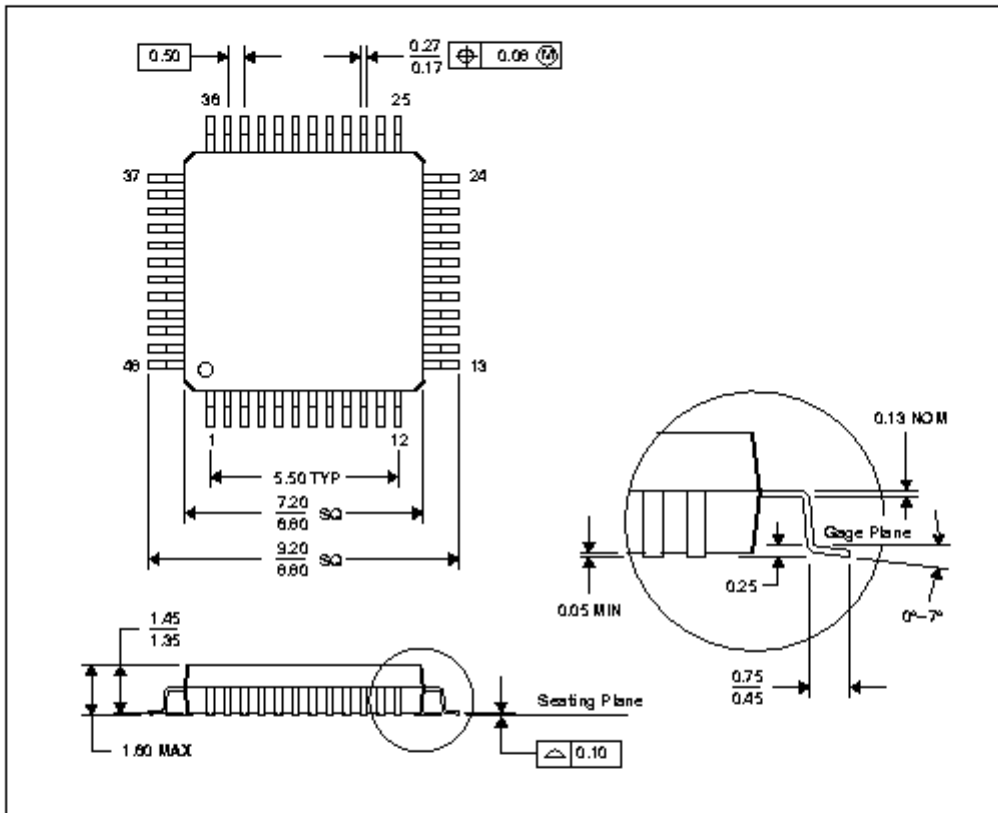

- NOTES: A. All linear dimensions are in millimeters.  
 B. This drawing is subject to change without notice.  
 C. Falls within JEDEC MO-136  
 D. This may also be a thermally-enhanced plastic package with leads connected to the die pads.