

# Fixed Magnitude Mismatch

# Electronic Line Stretcher

# ELS-450

180 to 450 MHz

## Maximum Ratings

Operating Temperature	0°C to 50°C
Storage Temperature	-40°C to 100°C
RF Input Power	13 dBm
Control Voltage	0.5V to 30V

## Pin Configuration

RF IN	1
MONITOR OUT	2
CONTROL	3

## Features

- over 360° phase shift of the reflected signal
- normalized and stable magnitude of the reflected signal
- voltage controlled for automated applications
- protected under US Patent No. 6,479,977

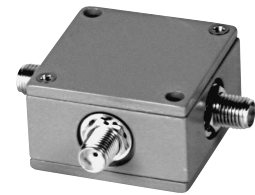

CASE STYLE: K18  
CONNECTOR: SMA FEMALE  
PRICE: \$149.95 ea.  
QTY.: (1-9)

## Applications

- automated load-pull measurement of oscillators

## Outline Drawing

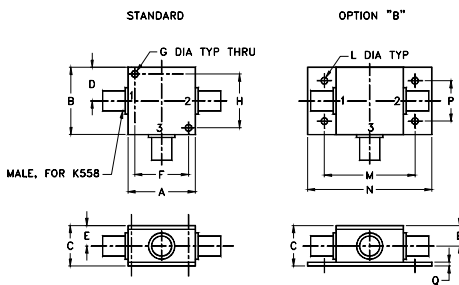

## Outline Dimensions (inch/mm)

A	B	C	D	E	F	G	H
1.25	1.25	.75	.63	.38	1.000	.125	1.000
31.75	31.75	19.05	16.00	9.65	25.40	3.18	25.40
J	K	L	M	N	P	Q	wt.
—	—	.125	1.688	2.18	.75	.07	grams
—	—	3.18	42.88	55.37	19.05	1.78	70.0

## Electrical Specifications

FREQUENCY RANGE (MHz) $f_L$ - $f_U$	INPUT POWER (dBm) Max.	PHASE RANGE (Degrees)		RETURN LOSS (dB) Typ.	CONTROL VOLTAGE (V)
		Min.	Max.		
180-450	10	360		10-12	0.5-25

## Application Block Diagram

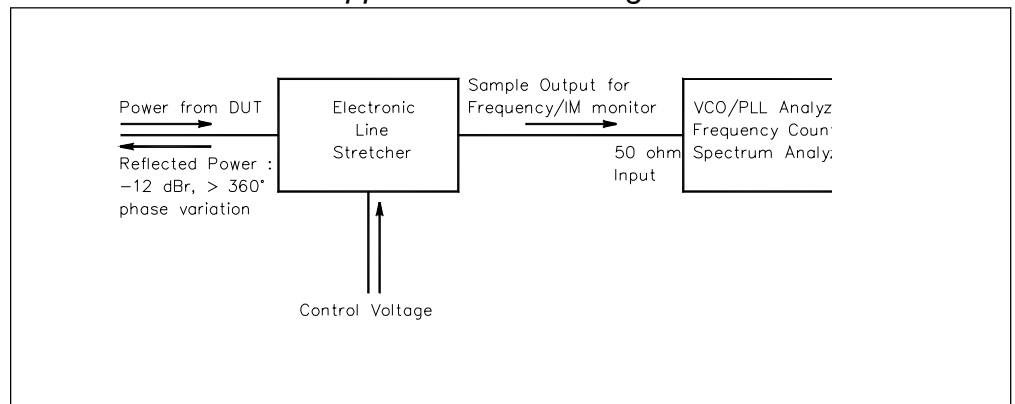

Maximum Phase Shift vs. Frequency at temperature extremes @ Pin = +7 dBm

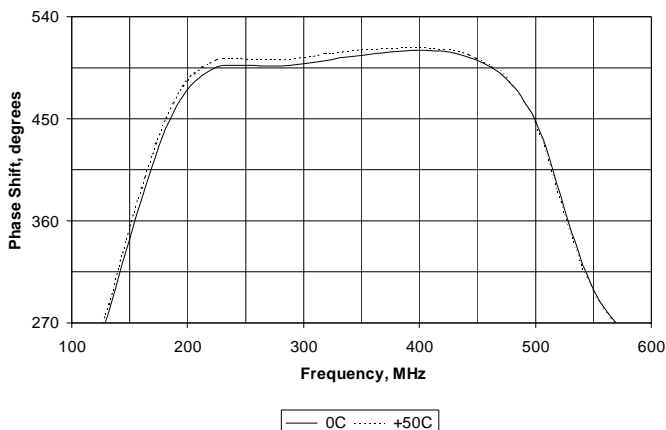

Return Loss vs. Frequency at temperature extremes @ Pin = +7 dBm

