

Design Idea DI-70

DPA-Switch® PoE Detection and Classification (Class 0) Interface Circuit



Application	Device	Power Output	Input Voltage	Output Voltage	Topology
PoE/VoIP	DPA424P	12.94 W	34-57 VDC	5 V / 7.5 V / 20 V	Forward

Design Highlights

- Simple, low-cost, discrete PoE interface circuit
- Low cost bipolar pass-switch: 87% efficient (Figure 5)
- MOSFET pass-switch: 97% efficient (Figures 2 and 5)
- Fully compliant with IEEE 802.3af

Operation

Power over Ethernet (PoE) is becoming widely adopted for networking and (VoIP) telecom applications. A typical PD solution is shown in Figure 1, having a PoE interface circuit and a *DPA-Switch* DC-DC converter block (see **DI-69** for full details of operation of the DC-DC converter).

The PoE specification requires the PD to provide three functions: detection, classification, pass-switch connection.

When an input voltage is first applied to the PD, it must present the correct detection impedance in the voltage range of 2.5 VDC to 10 VDC. This impedance is provided by R51.

The second (classification) phase occurs at input voltages 14.5 VDC to 20.5 VDC. The PD must draw a specified current

to identify the device class (Class 0 specifies 0 mA to 4 mA). This is again accomplished by resistor R51.

Bipolar Transistor Pass-Switch

In the third phase, the bipolar pass-switch (Q51 in Figure 1) connects the input voltage to the power supply at voltages above approximately 30 VDC ($28\text{ V} + V_{R52}$). Zener diode VR51 conducts, driving current through resistor R52 to the base of Q51. Resistor R53 prevents turn-on under other conditions. Once the power supply has started, components D51, D52, C51 and R54 enhance the base-current drive by coupling power from the power supply bias winding.

MOSFET Pass-Switch

An alternative MOSFET-based third phase solution (Figure 2) connects the input to the power supply at input voltages above approximately 30 VDC ($28\text{ V} + V_{G(Q51)}$). Resistor R53 prevents turn-on under other conditions and Zener diode VR52 limits the Q51 gate-source voltage when the input voltage is high (>42 VDC). In the last phase of start up,

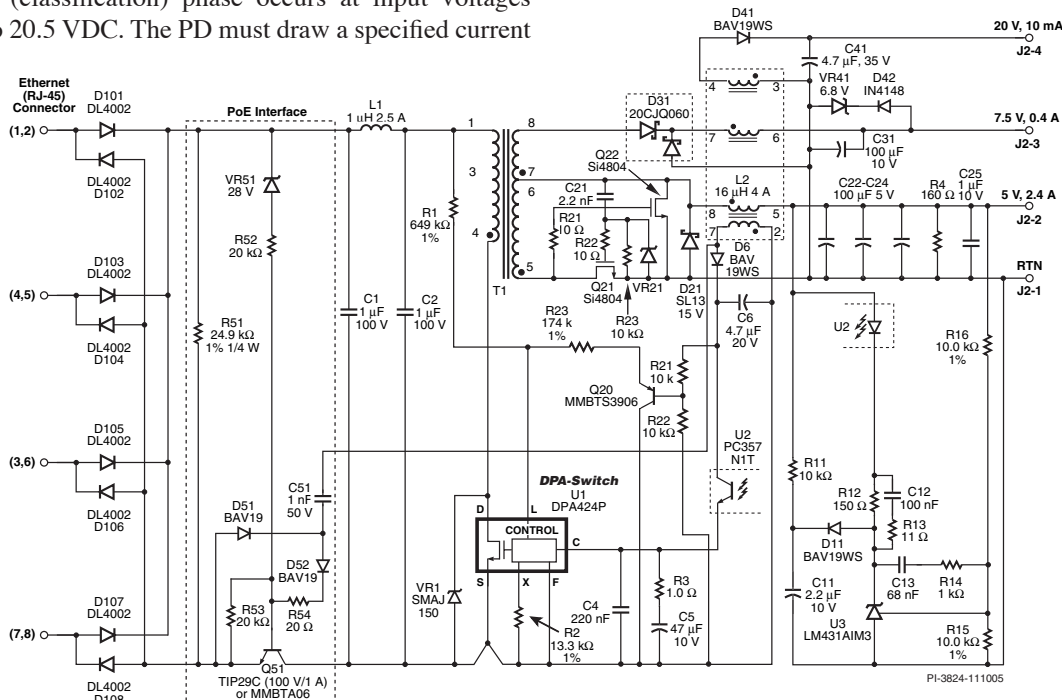

Figure 1. PoE Interface Circuit—Using a Bipolar Transistor Pass-Switch and DPA424P.

the under-voltage threshold for the *DPA-Switch* is programmed by components R1, R21, R22, R23 and Q20, setting the turn-on voltage to 42 VDC and turn-off voltage to 34 VDC.

Key Design Points

Bipolar Transistor Pass-Switch:

- Choose Q51 bipolar with sufficient current and voltage capability and highest available DC-current gain.
- Choose R52 to give sufficient base-drive at turn-on, to allow the DC-DC converter to start.
- Choose R54 (typically 10-20 Ω) to limit the capacitively coupled current spike during switching.

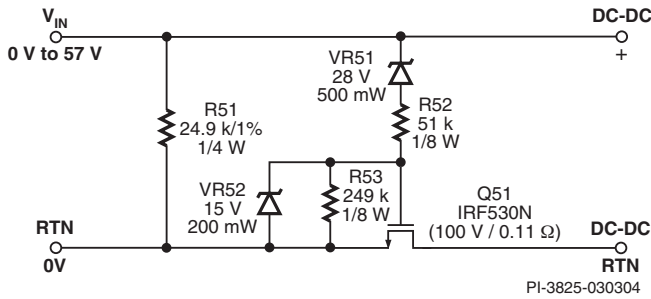

Figure 2. PoE Interface Circuit—Using a MOSFET Pass-Switch.

MOSFET Pass-Switch:

- Choose R52 to limit power dissipation in VR51 and VR52.
- Choose R53 to ensure MOSFET turn-off below 28 VDC.
- Choose VR51 to block Q51 turn-on below <28 VDC.
- Higher values of R52, R53 and VR51 will limit dissipation.
- Choose VR52 to limit the maximum gate to source voltage on Q51 (typically 15 VDC is a good choice).

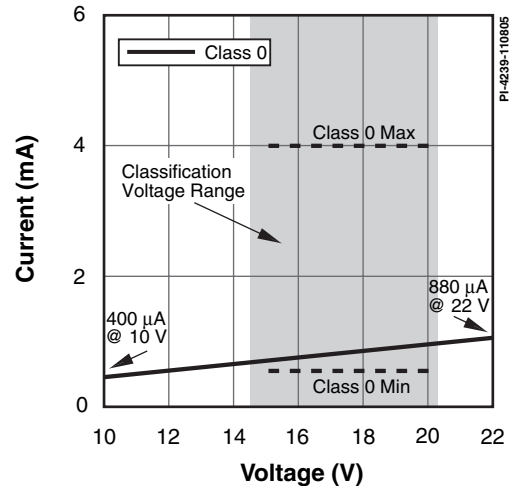

Figure 4. Classification Current (Class 0).

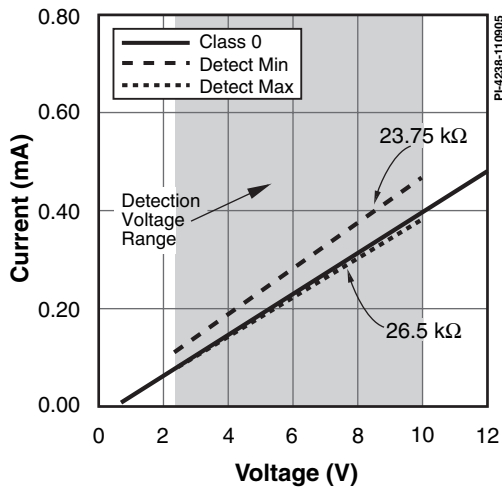

Figure 3. Detection Impedance V-I Curve.

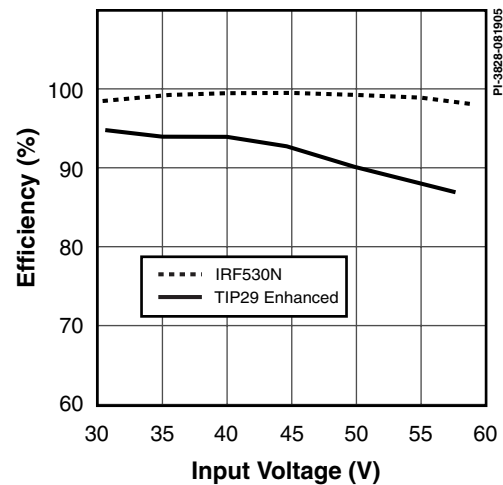

Figure 5. Pass-Switch Efficiency.

For the latest updates, visit www.powerint.com

Power Integrations reserves the right to make changes to its products at any time to improve reliability or manufacturability. Power Integrations does not assume any liability arising from the use of any device or circuit described herein. POWER INTEGRATIONS MAKES NO WARRANTY HEREIN AND SPECIFICALLY DISCLAIMS ALL WARRANTIES INCLUDING, WITHOUT LIMITATION, THE IMPLIED WARRANTIES OF MERCHANTABILITY, FITNESS FOR A PARTICULAR PURPOSE, AND NON-INFRINGEMENT OF THIRD PARTY RIGHTS. The products and applications illustrated herein (transformer construction and circuits external to the products) may be covered by one or more U.S. and foreign patents or potentially by pending U.S. and foreign patent applications assigned to Power Integrations. A complete list of Power Integrations' patents may be found at www.powerint.com. Power Integrations grants its customers a license under certain patent rights as set forth at <http://www.powerint.com/ip.htm>.

The PI logo, **TOPSwitch**, **TinySwitch**, **LinkSwitch**, **DPA-Switch**, **EcoSmart**, **Clampless**, **E-Shield**, **Filterfuse**, **PI Expert** and **PI FACTS** are trademarks of Power Integrations, Inc. Other trademarks are property of their respective companies.

©Copyright 2005, Power Integrations, Inc.

Power Integrations		5245 Hellyer Avenue		San Jose, California 95138	
MAIN PHONE NUMBER	APPLICATIONS HOTLINE	APPLICATIONS FAX	For a complete listing of worldwide sales offices,		
+1 408-414-9200	+1 408-414-9660	+1 408-414-9760	please visit www.powerint.com		

