



# CMI 8768+

PCI 8CH Integrated Sound Chip

*Supports Dolby® Digital Live 5.1 Encoder*



Data Sheet

Rev. 1.0  
Dec. 1, 2004

## NOTICES

THIS DOCUMENT IS PROVIDED “AS IS” WITH NO WARRANTIES WHATSOEVER, INCLUDING ANY WARRANTY OF MERCHANTABILITY, NONINFRINGEMENT, FITNESS FOR ANY PARTICULAR PURPOSE, OR ANY WARRANTY OTHERWISE ARISING OUT OF ANY PROPOSAL, DOCUMENT OR SAMPLE.

ALL RIGHTS RESERVED. NO PART OF THIS DOCUMENT MAY BE REPRODUCED OR TRANSMITTED IN ANY FORM OR BY ANY MEANS, ELECTRONIC OR MECHANICAL, INCLUDING INFORMATION STORAGE AND RETRIEVAL SYSTEMS, WITHOUT PERMISSION IN WRITING FROM THE C-MEDIA ELECTRONICS, INC.

**Third-party brands and names are the property of their respective owners.  
Dolby® Digital Live logo is the trademark of Dolby Lab.**

Copyright 2004-2005 © C-Media Electronics Inc.

### **C-Media Electronics, Inc.**

6F, 100, Sec. 4, Civil Boulevard, Taipei, Taiwan 106, R.O.C.

TEL: 886-2-8773-1100      FAX: 886-2-8773-2211

<http://www.cmedia.com.tw>

For detailed product information, please contact [sales@cmedia.com.tw](mailto:sales@cmedia.com.tw)

## Contents

0.	Revision History .....	3
1.	Features.....	4
2.	Overview.....	5
3.	Block Diagram.....	7
4.	Pin Assignment .....	8
5.	Pin Description .....	9
5.1	Digital I/O .....	9
5.2	Analog I/O .....	10
5.3	Power & Ground .....	10
5.4	NC .....	10
6.	Electrical Characteristics.....	11
6.1	Maximum Ratings .....	11
6.2	Recommended Operating Conditions.....	11
6.3	Power Consumption.....	11
6.4	Digital Characteristics .....	11
6.5	AC Characteristics .....	12
6.6	Analog Performance .....	13
7.	Mechanical Dimensions .....	15

## List of Figures

Figure 1.	Graphic User Interface Samples-- Main Setting & Mixer .....	5
Figure 2.	Graphic User Interface Samples—Virtual Speaker SHIFTER & Sound Effect..	6
Figure 3.	Graphic User Interface Samples—Karaoke & Magic Voice & Information..	6
Figure 4.	Block Diagram .....	7
Figure 5.	Top View of CMI8768+.....	8
Figure 6.	Mechanical Dimension.....	15

## 0. Revision History

Date	Rev.	Release Note
2003/06/13	Rev. 0.1	- Preliminary vision
2003/07/17	Rev. 0.2	- Change feature and pin description
2003/10/13	Rev. 0.3	- Add analog performance data
2004/12/01	Rev. 1.0	<ul style="list-style-type: none"><li>- Update feature/overview description (Support 96K/24Bit output)</li><li>- Clarify block diagram (no legacy/SBPRO support)</li><li>- Correct pin function (#125 XS6CH=&gt;GND; #90-97 XGD0-XGD7=&gt;NC; #59 EXTBASS type from analog output to input)</li><li>- Add pin #62 description: XINTREF =&gt; Internal reference voltage</li><li>- Clarify DirectX9.0 installed is required for 8ch playback support on Windows</li><li>- Indicate pin#9 IDSEL can work only with A16~31</li><li>- Modify SPDIF-Out high voltage from VDD to 5V</li><li>- Add Electrical Characteristics data and update analog performance</li></ul>

## 1. Features



- The global first 8CH single sound chip supporting **Dolby® Digital Live 5.1 (AC-3) real-time interactive content encoder**
- **Full-duplex embedded 8CH DAC/2CH ADC**
- **Supports 96K/24bit playback; 48K/16bit recording**
- CE level high-quality Signal-to-Noise Ratio (SNR) ~ 100dB
- Integrated S/PDIF transmitter supports **44.1k/48k/96KHz sample-rate and 16/24bits resolution**
- **PCI Rev. 2.2** compliant with bus mastering modes
- Supports the latest **Dolby® Digital EX and DTS® ES 6.1/7.1CH DVD soundtrack playback**
- **Two S/PDIF inputs** for optical and coaxial connectors individually
- Built-in earphone buffer at Front-Out pins (32Ω loading)
- One GPIO (General purpose I/O) support
- External EEPROM Interface for SID R/W purpose
- Supports MPU401 MIDI UART port
- **DirectSound™ 3 HW acceleration compliant**
- **Power On/Off anti-pop circuit reference design**
- ACPI compliant power down management
- Zoomed Video Port support
- Industrial standard QFP-128 package
- Almost pin-to-pin compatible with CMI8738 series
- Digital power = 3.3V & 5V, Analog power = 5V

### Valuable S/W:

- **Dolby® Digital Live 5.1 (AC-3) real-time interactive content encoder** converting all digital audio sources (game audio, MP3, VCD, WMA, ...) into 5.1ch Dolby® Digital stream through S/PDIF output interface
- C-Media **Xear 3D™ 7.1 Virtual Speaker SHIFTER** technology
- Interesting **Magic Voice™** feature to disguise users' voice tone in all IP phones (Skype, MSN, Yahoo,...), online games, messenger, and Internet DJ/broadcasting applications
- Unique **Karaoke** functionality: Mic Echo, Key-shifting, Vocal Cancellation
- **CRL3D®** HRTF 3D positional sound enhancement from Sensaura® supporting multi-drive 7.1, EnvironmentFX, ZoomFX, MacroFX, etc.
- Supports most industrial standards of PC 3D sound for gaming, including **EAX™ 1.0&2.0, A3D™ 1.0, and DirectSound™ 3 SW**
- **10-band Equalizer** with 12 preset modes; **27 global environment effects**
- Support 7.1 CH digital audio playback for WinXP, 2K, ME, 98SE (Microsoft® DirectX V.9.0 above is required)
- WinCE driver and Linux OSS driver available (w/o DDLive)

## 2. Overview

CMI8768+ is the first high performance 8CH PCI integrated sound chip in the world supporting **Dolby® Digital Live 5.1 (AC-3) real-time interactive content encoder**. Dolby® Digital Live encodes all digital audio sources on PC such as 3D game audio, VCD, MP3, WMA, Internet radio... into 5.1CH Dolby® Digital stream transmitted via consumer standard S/PDIF link to external decoder/receiver and even Home Theater system. With Dolby® Digital Live encoder feature, users can easily connect PC audio to consumer sound system by S/PDIF interface. It realizes **Digital Home Entertainment PC** in the living room.

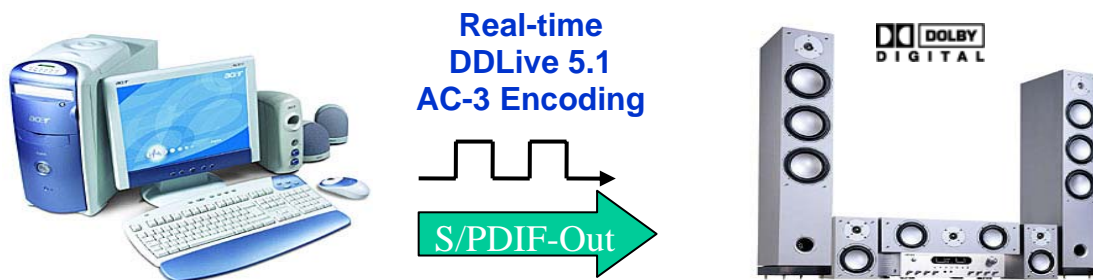

Integrated S/PDIF transmitter can also pass through 5.1 Dolby® Digital/DTS®, or 6.1/7.1 Dolby® Digital Surround EX/DTS ES DVD audio stream to external receiver satisfying audio enthusiasts and pioneers.



*Graphic User Interface Samples-- Main Setting & Mixer*

Being compatible with various industrial standards for gaming such as EAX™ 1.0&2.0, A3D™ 1.0, Direct Sound™ 3D powered by Sensaura® CRL3D HRTF 3D engine, C-Media CMI8768+ can provide enthusiastic gamers breathtaking sound experience in gaming.

C-Media proprietary **Xear 3D™ sound technology** empowers users to shift virtual speakers anywhere they want for optimizing the personal sound field. **Virtual speakers** can even deliver up-to-7.1 channel surround sounds over only 2 physical speakers or headphones. C-Media unique **Magic Voice™** functionality can reform your microphone voice through the recording process delivering amazing disguise effects for fun in many applications, such as Internet phone, messenger, online games, etc. **Microphone echo** and **key-shifting** features are well designed for karaoke application. Other sound effects like **10-band Equalizer** and **27 environment effects** can enrich user's audio experience and enjoyment.



*Graphic User Interface Samples—DDLive Encoder, Virtual Speaker SHIFTER & Sound Effects*

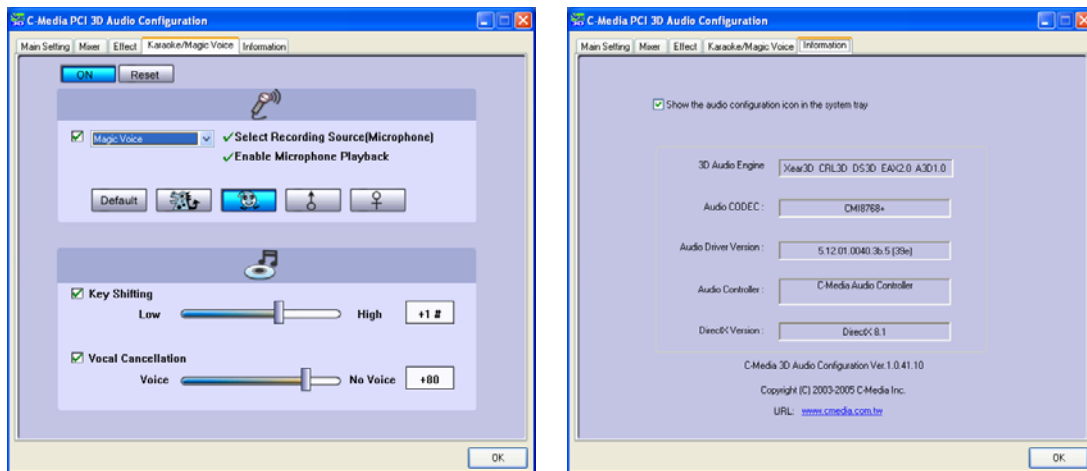

*Graphic User Interface Samples—Karaoke & Magic Voice & Information*



### 3. Block Diagram

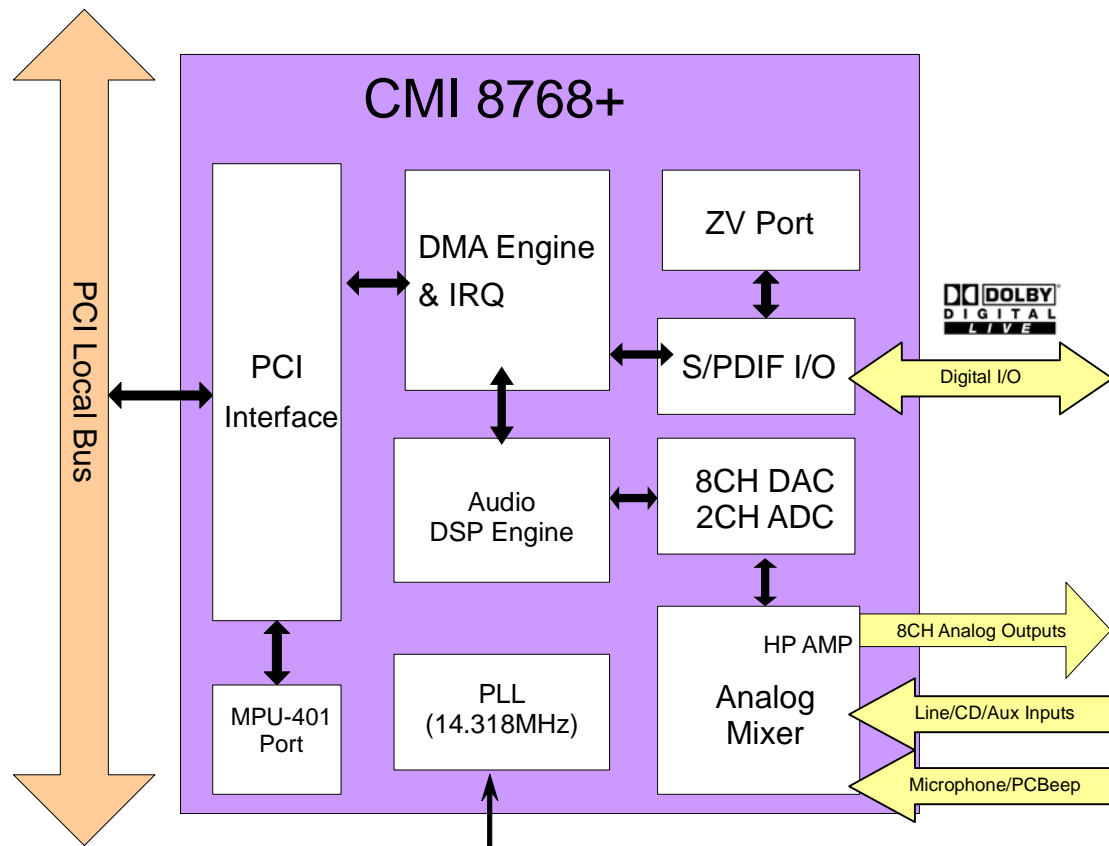

*Block Diagram*

## 4. Pin Assignment



*Top View of CMI8768+*

## 5. Pin Description

### Digital I/O

Pin No	Signal Name	Type	Description
1-2, 5-7, 12-16, 19-21, 32-35, 38-41, 43-44, 47-52, 126-128	XA31 - XA0	I/O	PCI bus address and data lines
117	XINTA	O	Interrupt request, active-low
119	XPRST	I	Reset
120	XCLK33	I	PCI bus clock
121	XGNT	I	Bus master grant, active-low.
122	XREQ	O	Bus master request, tri-state output, active-low.
9	XIDSEL	I	ID select, active-high. (only works with A16~31 pin of host controller)
23	XFRAME	I/O	Cycle frame, active-low.
24	XIRDY	I/O	Initiator ready, active-low. The bus master device is ready to transmit or receive data.
25	XTRDY	I/O	Target ready, active-low. The target device is ready to transmit or receive data.
26	XDEVSEL	I/O	Device select, active-low. The target device has decoded the address of the current transaction as its own chip select range.
29	XSTOP	I/O	Stop transaction, active-low. The target device request to the master to stop the current transaction.
30	XPAR	I/O	Parity. The pin indicates even parity across XA31-XA9 and XCBE3-XCBE0 for both address and data phases.
8, 22, 31, 42	XCBE0 XCBE3	- I/O	Multiplexed command / byte enable. These pins indicate cycle type during the address phase of a transaction.
88	XTXD	O	MIDI transmit data
89	XRXD	I	MIDI receive data
55	XIN	I	14.318 MHz crystal input or ext. oscillator input
56	XOUT	O	13.318 MHz crystal output or NC
87	XGBIO0	I/O	General purpose I/O
84	XEECS	O	EEPROM chip select
85	XMBCSZ	I	Audio chip enable select (low:enable)
112	ZVCLK	I	ZV port clock
98	XSPDIFO	O	S/PDIF output (5V)
86	XSPDIFI	I	S/PDIF input 1 / ZV port LR channel clock
113	XSPDIFI2	I	S/PDIF input 2 (TTL 5V) / ZV port data input

## Analog I/O

Pin No	Signal Name	Type	Description
57,58	XSUROUTL-R	O	Back surround out L/R channel
59	EXTBASS	I	External bass input
62	XINTREF	O	Internal reference voltage (for testing purpose)
64,65	XADOUTL-R	O	Front out L/R channel
66,67	XADCFL-R	O	ADC S/H capacitors
68	XCNOUT	O	Center channel output
69	XBSOUT	O	Bass channel output
70	XCDGND	O	CD audio differential ground channel output
71,72	XCDL-R	O	CD audio differential L/R channel output
73,74	XREARL-R	O	Side surround out L/R channel
75,76	XLNL-R	I	Line-In L/R channel
77,78	XAUXL-R	I	Aux input L/R channel
79	XPCSPKIN	I	PC beep or mono input
80	XMIC	I	Microphone input

## Power & Ground

Pin No	Signal Name	Type	Description
4, 10, 18, 27, 37, 45, 100, 124	VDDIO	I	PCI I/O power pin (3.3V)
54, 115	VDDCORE	I	Core logic power pin (3.3V)
83	VDD5V	I	PCI I/O power pin (5V)
3, 11, 17, 28, 36, 46, 53, 82, 99, 116, 125	GND	I	Digital ground
61, 81	AVDD	I	Analog I/O power pin
60, 82	AGND	I	Analog ground

## NC

Pin No	Signal Name
63, 90-97, 101 - 111, 114, 118, 123	NC

## 6. Electrical Characteristics

### Maximum Ratings

Parameter	Symbol	Min.	Max.	Unit
Digital power voltage	DVDD	3	3.6	V
Analog power voltage	AVDD	3	5.5	V
Digital Input Voltage	VIND	-0.5	3.6	V
Analog Input Voltage	VINA	-0.5	5.5	V
Operating temperature range	TO	0	70	°C
Storage temperature range	TST	-40	125	°C
Maximum power dissipation	PDMAX		300	MW

### Recommended Operating Conditions

Parameter	Symbol	Min.	Typ.	Max.	Unit
Digital Operating Voltage	DVDD	3.135	3.3	3.465	V
Analog Operating voltage	AVDD	4.75	5	5.25	V
Operating Ambient Temperature	TO	0	25	70	°C

### Power Consumption

Parameter	Min.	Typ.	Max.	Unit
Power Supply Current (Normal)				
AVDD (5.0V)	-	35	-	mA
DVDD (3.3V)	-	10	-	mA

### Digital Characteristics

PARAMETER	Symbol	Condition	Min.	Typ.	Max.	Unit
Input high voltage(PCI I/O)	VIH		2.0	-	VDD+0.3	V
Input low voltage (PCI I/O)	VIL		-0.5	-	0.8	V
Output high voltage	VOH	I <sub>OH</sub> =1.5mA	2.4	-	VDD	V
Output low voltage	VOL	I <sub>OL</sub> =-0.5mA	0.0	0.2	0.4	V
Input Leakage Current	IIL	0<Vin<VDD	-70	-	70	μA
Output Leakage Current	IOL		-70	-	70	μA
SPDIF IN input high voltage	VIH1		2.6	-	-	V
SPDIF IN input low voltage	VIL1		-	-	2.4	V
SPDIF output high voltage	VOH1		-	VDD5V	-	V
SPDIF output low voltage	VOL1		-	GND	-	V

Input Pin Capacitance	Cin		-	-	10	pF
Pin Inductance	Lpin		-	-	20	nH

## AC Characteristics

Parameter	Symbol	Condition	Min.	Max.	Units
High Clamp Current	Ich	$V_{dd}+4 > V_{in} \geq V_{dd}+1$	$25+(V_{in}-V_{dd}-1)/0.015$	-	mA
Low Clamp Current	Icl	$-3 < V_{in} \leq -1$	$-25+(V_{in}+1)/0.015$	-	mA
Output Rise Slew Rate	SLEW <sub>r</sub>	0.2V <sub>dd</sub> -0.6V <sub>dd</sub> load	1	4	V/ns
Output Fall Slew Rate	SLEW <sub>f</sub>	0.6V <sub>dd</sub> -0.2V <sub>dd</sub> load	1	4	V/ns

## Analog Performance

The measurements are performed under the circumstance as:

$T_{\text{ambient}} = 25^{\circ}\text{C}$ ,  $AV_{\text{dd}} = 5.0\text{V} \pm 5\%$ ,  $DV_{\text{dd}} = 3.3\text{V} \pm 5\%$ , 10k $\Omega$ /50pF external load. Input is 1 kHz sine wave; Sampling frequency = 48 kHz; Bandwidth = 20 to 20 kHz; 0dB attenuation; All sound effects such as 3D effects are disabled.

Parameter	Minimum	Typical	Maximum	Units
Full Scale Input Voltage:				
Line Inputs (Mixer)	-	1.1	1.25	Vrms
Line Inputs (A/D)	-	-	1.25	Vrms
Mic Inputs (20dB boost)	-	0.1	1.25	Vrms
Full Scale Output Voltage:				
Front_Out	-	1.1	-	Vrms
Side_Surround_Out	-	1.1	-	Vrms
Center / LFE_out	-	1.1	-	Vrms
Back_Surround_Out	-	1.1	-	Vrms
SNR (Idle)				-
A/A	-	100	-	dB
D/A	-	101	-	dB
A/D	-	86	-	dB
Dynamic Range (-60dB)				
A/A	-	100	-	dB
D/A	-	94	-	dB
A/D	-	85	-	dB
THD+N				
A/A	-	0.005	-	%
D/A	-	0.017	-	%
A/D	-	0.015	-	%
Frequency Response				
A/A	5	-	22,000	Hz
D/A	5	-	22,000	Hz
A/D	10	-	22,000	Hz
Cross-talk @ 10KHz (A/A)	-	100	-	dB
Transition Band	19,200		28,800	Hz
Stop Band	28,800		$\infty$	Hz
Stop Band Rejection	-	-70	-	dB
Out-Of-Band Rejection	-	-65	-	dB
Power Supply Rejection Ratio	-	-65	-	dB
Master Volume Gain (32 steps)				
Step Size		1.5		dB
Control Range	-54	-	+6	dB
Analog Input Gain (16 steps)				
Step Size		2		dB
Control Range	-30	-	0	dB
Mic Input Gain (16 steps)				
Step Size		3		dB
Control Range	-22	-	+24	dB
Mic Boost Gain	-	+20	-	dB
PCSPK Input Gain (4 steps)				
Step Size		8		dB
Control Range	-24	-	0	dB
Recording Gain (16 steps)				
Step Size		1.5		dB
Control Range	0	-	+22.5	dB
Input Impedance				

Parameter	Minimum	Typical	Maximum	Units
Line-In, CD, Aux, PCSPK	-	60	-	K $\Omega$
Mic (w/o Boost)	-	30	-	K $\Omega$
Mic (w/ Boost)	-	10	-	K $\Omega$
Output Impedance				
Amplifier Output	-	2	-	$\Omega$
Non-amp Output	-	200	-	$\Omega$
Output Power				
Line-Out (Front) @32 $\Omega$ Load	-	50	-	mW
Line-Out (Front) @10K $\Omega$ Load	-	0.16	-	mW
Vrefout	-	2.25	-	V



## 7. Mechanical Dimensions

### QFP-128

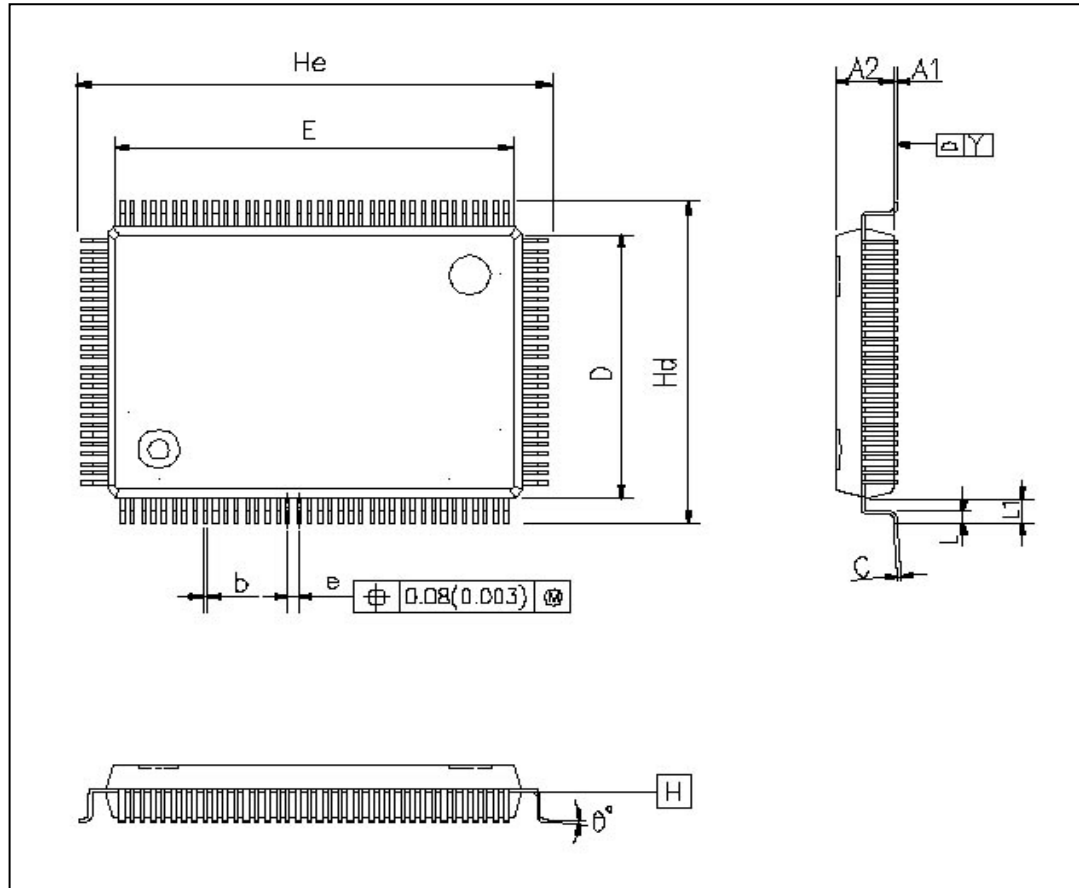

*Mechanical Dimension*

Symbols	Min.	Typ.	Max.	Notes
A1	0.25	0.35	0.45	1. Jeduc outline : N/A 2. Datum plane $\square H$ is located at the bottom of the mold parting line coincident with where the lead exits the body.
A2	2.57	2.72	2.87	
b	0.10	0.20	0.30	
C	0.10	0.15	0.20	
D	13.90	14.00	14.10	3. Dimensions E and D do not include mold protrusion. Allowable protrusion is 0.25 mm per side. Dimensions E and D do include mold mismatch and are determined at datum plane $\square H$ . 4. Dimension b does not include dambar protrusion.
E	19.90	20.00	20.10	
e	-	0.50	-	
Hd	17.00	17.20	17.40	
He	23.00	23.20	23.40	
L	0.65	0.80	0.95	
L1	-	1.60	-	
Y	-	-	0.08	
$\theta^\circ$	0	-	12	

**Unit : mm**

~The End of Datasheet~