

DATA SHEET

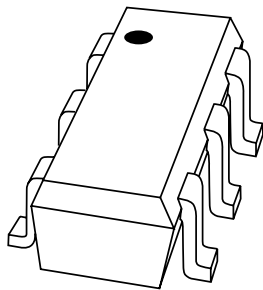

BGM1012 MMIC wideband amplifier

Product specification
Supersedes data of 2002 May 16

2002 Sep 06

MMIC wideband amplifier

BGM1012

FEATURES

- Internally matched to 50 Ω
- Very wide frequency range (4 Ghz at 3 dB bandwidth)
- Very flat 20 dB gain (DC to 2.9 Ghz at 1 dB flatness)
- 10 dBm saturated output power at 1 GHz
- High linearity (18 dBm IP3_(out) at 1 GHz)
- Low current (14.6 mA)
- Unconditionally stable.

APPLICATIONS

- LNB IF amplifiers
- Cable systems
- ISM
- General purpose.

DESCRIPTION

Silicon Monolithic Microwave Integrated Circuit (MMIC) wideband amplifier with internal matching circuit in a 6-pin SOT363 SMD plastic package.

PINNING

PIN	DESCRIPTION
1	V _S
2, 5	GND2
3	RF out
4	GND1
6	RF in

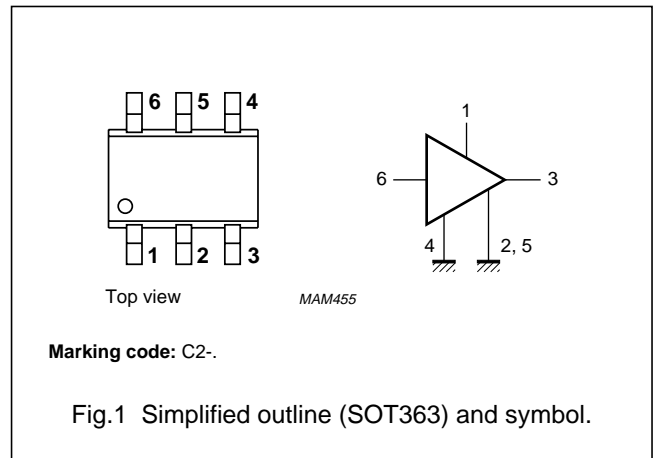

QUICK REFERENCE DATA

SYMBOL	PARAMETER	CONDITIONS	TYP.	MAX.	UNIT
V _S	DC supply voltage		3	4	V
I _S	DC supply current		14.6	–	mA
S ₂₁ ²	insertion power gain	f = 1 GHz	20.1	–	dB
NF	noise figure	f = 1 GHz	4.8	–	dB
P _{L(sat)}	saturated load power	f = 1 GHz	9.7	–	dBm

CAUTION

This product is supplied in anti-static packing to prevent damage caused by electrostatic discharge during transport and handling. For further information, refer to Philips specs.: SNW-EQ-608, SNW-FQ-302A and SNW-FQ-302B.

MMIC wideband amplifier

BGM1012

LIMITING VALUES

In accordance with the Absolute Maximum Rating System (IEC 60134).

SYMBOL	PARAMETER	CONDITIONS	MIN.	MAX.	UNIT
V_S	DC supply voltage	RF input AC coupled	–	4	V
I_S	supply current		–	50	mA
P_{tot}	total power dissipation	$T_s \leq 90\text{ °C}$	–	200	mW
T_{stg}	storage temperature		–65	+150	°C
T_j	operating junction temperature		–	150	°C
P_D	maximum drive power		–	10	dBm

THERMAL CHARACTERISTICS

SYMBOL	PARAMETER	CONDITIONS	VALUE	UNIT
$R_{th\ j-s}$	thermal resistance from junction to solder point	$P_{tot} = 200\text{ mW}; T_s \leq 90\text{ °C}$	300	K/W

MMIC wideband amplifier

BGM1012

CHARACTERISTICS

$V_S = 3\text{ V}$; $I_S = 14.6\text{ mA}$; $T_j = 25\text{ °C}$; unless otherwise specified.

SYMBOL	PARAMETER	CONDITIONS	MIN.	TYP.	MAX.	UNIT
I_S	supply current		11	14.6	19	mA
$ S_{21} ^2$	insertion power gain	f = 100 MHz	19	19.5	20	dB
		f = 1 GHz	19	20.1	21	dB
		f = 1.8 GHz	19	20.4	21	dB
		f = 2.2 GHz	19	20.4	22	dB
		f = 2.6 GHz	18	19.9	21	dB
		f = 3 GHz	16	18.7	20	dB
$R_{L\text{ IN}}$	return losses input	f = 1 GHz	9	11	–	dB
		f = 2.2 GHz	13	15	–	dB
$R_{L\text{ OUT}}$	return losses output	f = 1 GHz	11	14	–	dB
		f = 2.2 GHz	10	13	–	dB
$ S_{12} ^2$	isolation	f = 1 GHz	30	33	–	dB
		f = 2.2 GHz	35	38	–	dB
NF	noise figure	f = 1 GHz	–	4.8	5.1	dB
		f = 2.2 GHz	–	4.9	5.3	dB
BW	bandwidth	at $ S_{21} ^2$ –3 dB below flat gain at 1 GHz	3.1	3.6	–	GHz
K	stability factor	f = 1 GHz	1.5	2.1	–	–
		f = 2.2 GHz	3	3.4	–	–
$P_{L(\text{sat})}$	saturated load power	f = 1 GHz	8	9.7	–	dBm
		f = 2.2 GHz	3.5	5.6	–	dBm
$P_{L\text{ 1 dB}}$	load power	at 1 dB gain compression; f = 1 GHz	4	6.0	–	dBm
		at 1 dB gain compression; f = 2.2 GHz	1.5	3.4	–	dBm
$IP3_{(\text{in})}$	input intercept point	f = 1 GHz	–4	–2	–	dBm
		f = 2.2 GHz	–9	–7	–	dBm
$IP3_{(\text{out})}$	output intercept point	f = 1 GHz	16	18	–	dBm
		f = 2.2 GHz	11	13	–	dBm

MMIC wideband amplifier

BGM1012

APPLICATION INFORMATION

Figure 2 shows a typical application circuit for the BGM1012 MMIC. The device is internally matched to 50 Ω, and therefore does not need any external matching. The value of the input and output DC blocking capacitors C2 and C3 should not be more than 100 pF for applications above 100 MHz. However, when the device is operated below 100 MHz, the capacitor value should be increased.

The nominal value of the RF choke L1 is 100 nH. At frequencies below 100 MHz this value should be increased to 220 nH. At frequencies above 1 GHz a much lower value (e.g. 10 nH) can be used to improve return losses. For optimal results, a good quality chip inductor such as the TDK MLG 1608 (0603), or a wire-wound SMD type should be chosen.

Both the RF choke L1 and the 22 nF supply decoupling capacitor C1 should be located as closely as possible to the MMIC.

Separate paths must be used for the ground planes of the ground pins GND1 and GND2, and these paths must be as short as possible. When using vias, use multiple vias per pin in order to limit ground path inductance.

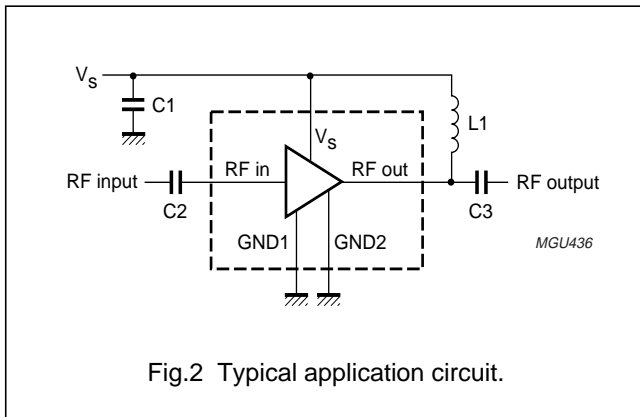

Fig.2 Typical application circuit.

Figure 3 shows two cascaded MMICs. This configuration doubles overall gain while preserving broadband characteristics. Supply decoupling and grounding conditions for each MMIC are the same as those for the circuit of Fig.2.

The excellent wideband characteristics of the MMIC make it an ideal building block in IF amplifier applications such as LBNs (see Fig.4).

As a buffer amplifier between an LNA and a mixer in a receiver circuit, the MMIC offers an easy matching, low noise solution (see Fig.5).

In Fig.6 the MMIC is used as a driver to the power amplifier as part of a transmitter circuit. Good linear performance and matched input and output offer quick design solutions in such applications.

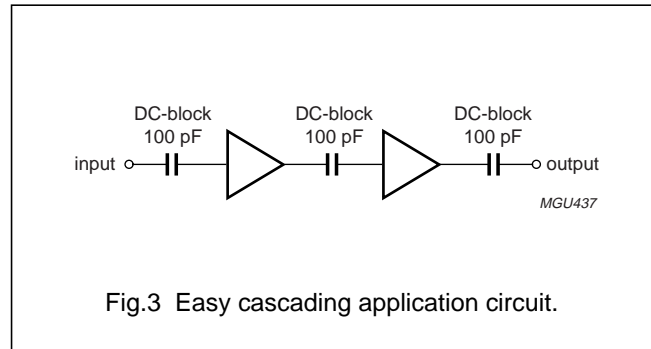

Fig.3 Easy cascading application circuit.

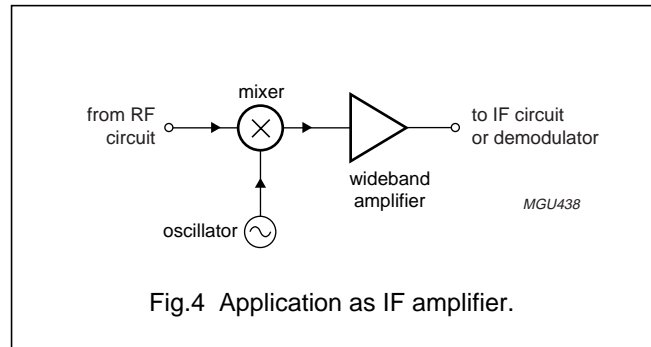

Fig.4 Application as IF amplifier.

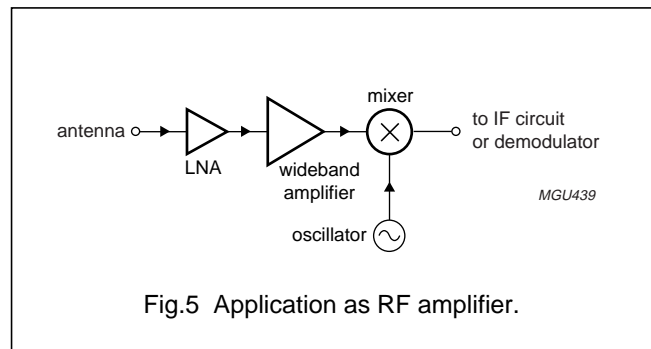

Fig.5 Application as RF amplifier.

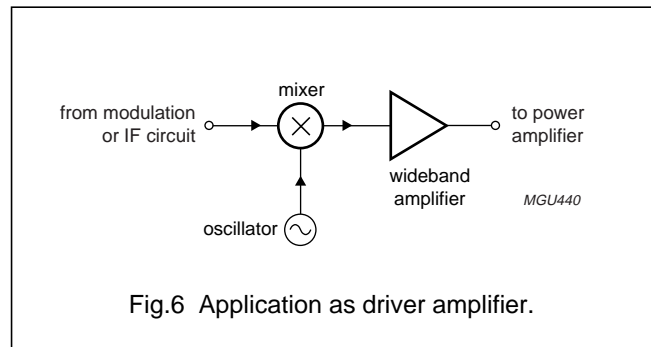
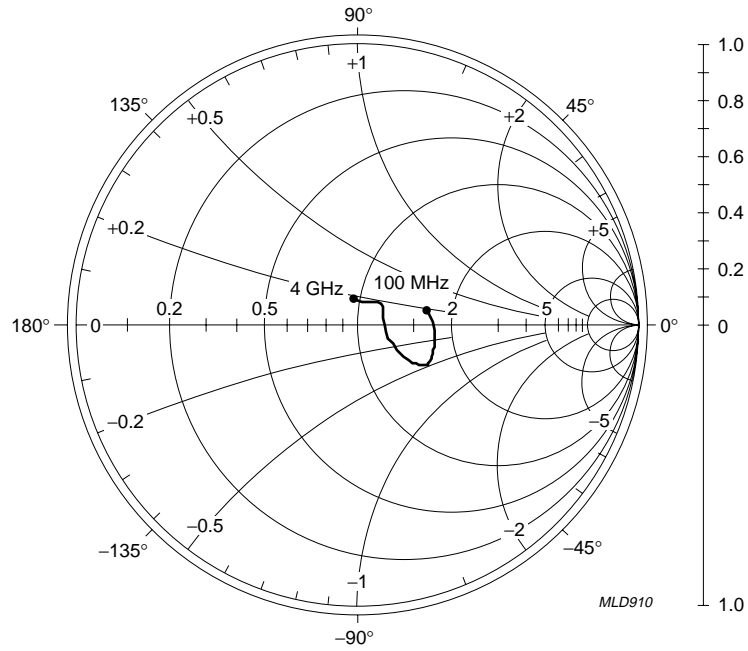

Fig.6 Application as driver amplifier.

MMIC wideband amplifier

BGM1012



$I_S = 14.6 \text{ mA}$; $V_S = 3 \text{ V}$; $P_D = -30 \text{ dBm}$; $Z_O = 50 \Omega$.

Fig.7 Input reflection coefficient (s_{11}); typical values.

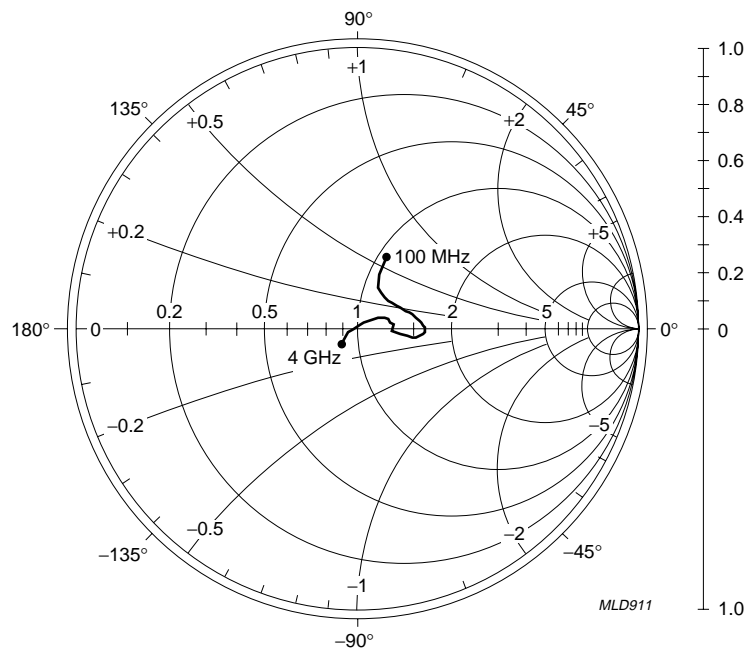

$I_S = 14.6 \text{ mA}$; $V_S = 3 \text{ V}$; $P_D = -30 \text{ dBm}$; $Z_O = 50 \Omega$.

Fig.8 Output reflection coefficient (s_{22}); typical values.

MMIC wideband amplifier

BGM1012

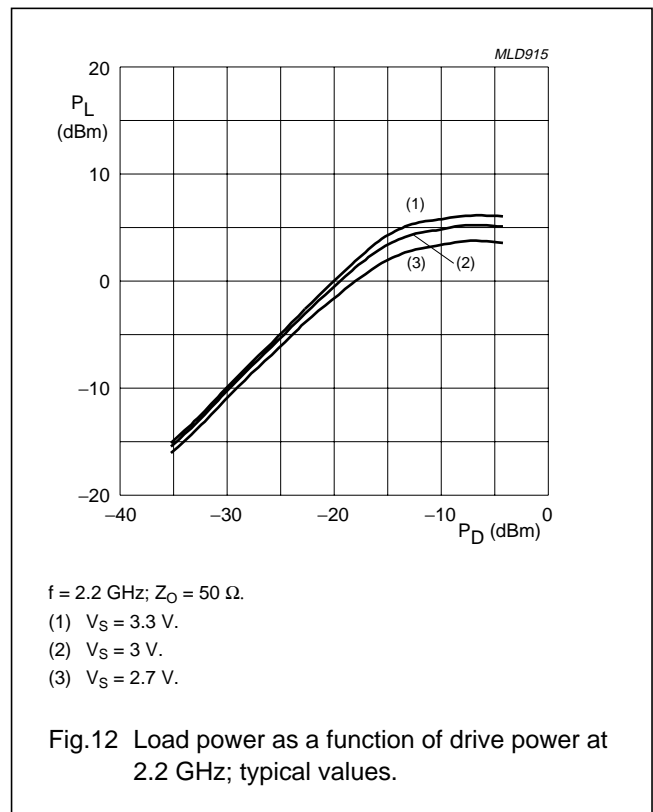
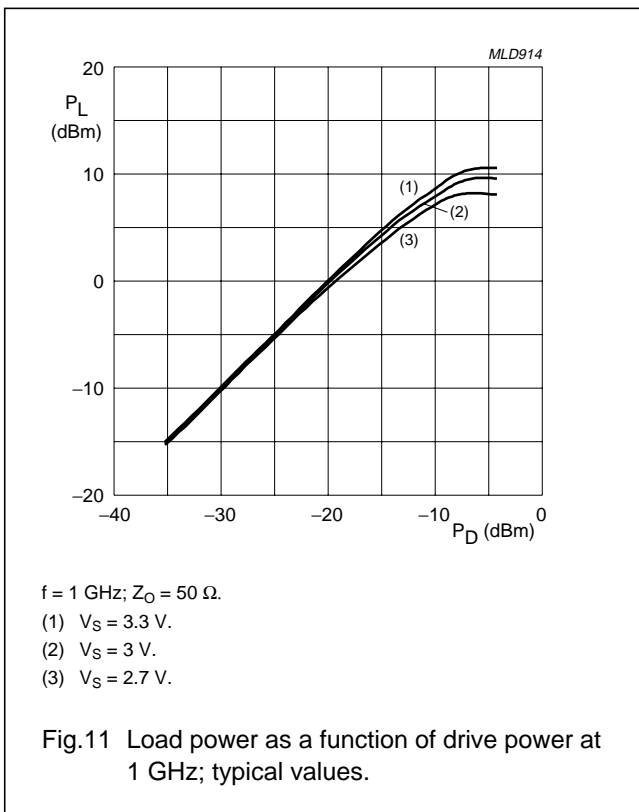
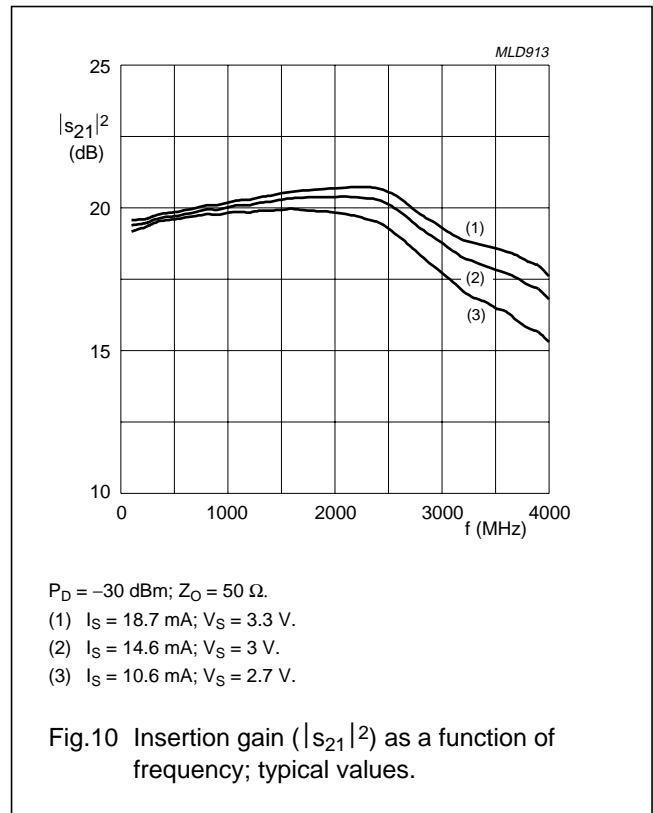
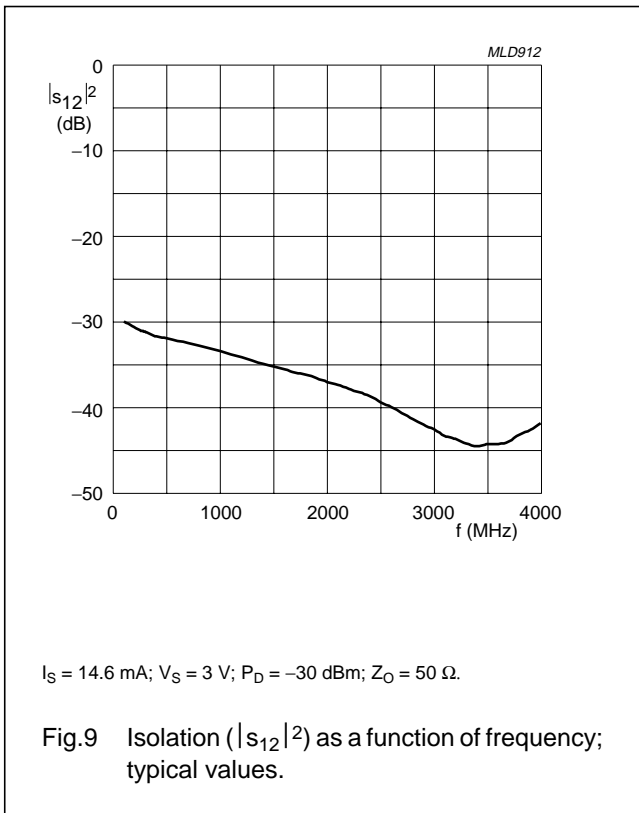

MMIC wideband amplifier

BGM1012

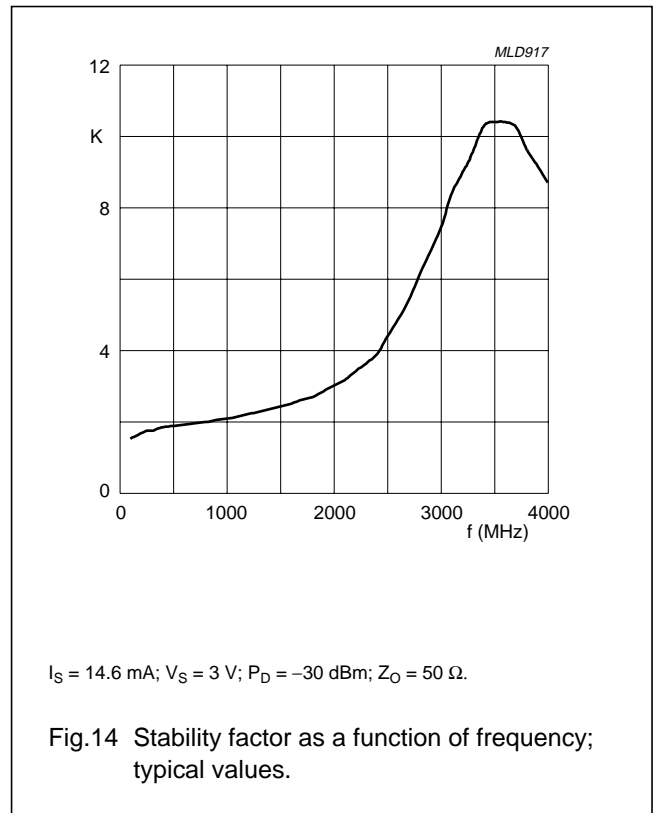
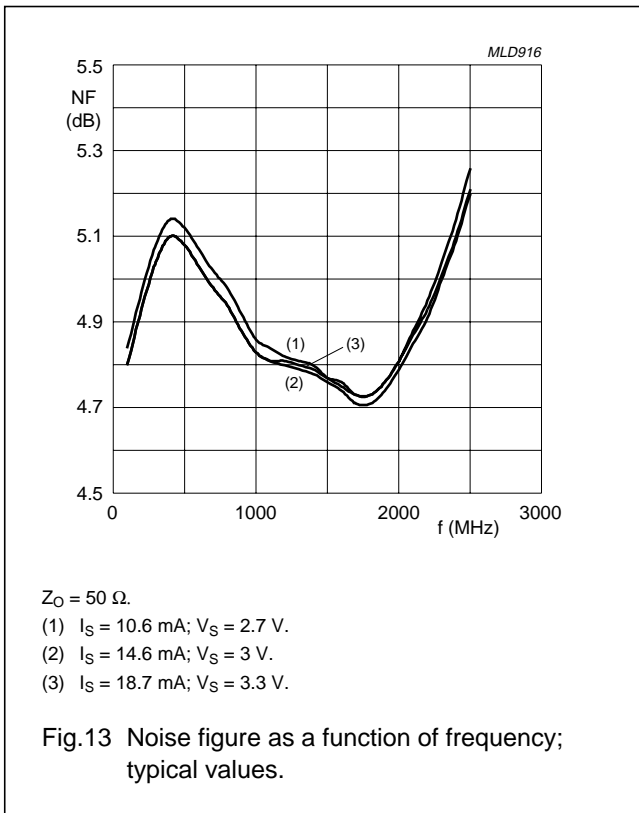

MMIC wideband amplifier

BGM1012

Scattering parameters

 $V_S = 3 \text{ V}$; $I_S = 14.6 \text{ mA}$; $P_D = -30 \text{ dBm}$; $Z_O = 50 \text{ } \Omega$; $T_{\text{amb}} = 25 \text{ } ^\circ\text{C}$.

f (MHz)	S ₁₁		S ₂₁		S ₁₂		S ₂₂		K-FACTOR
	MAGNITUDE (ratio)	ANGLE (deg)	MAGNITUDE (ratio)	ANGLE (deg)	MAGNITUDE (ratio)	ANGLE (deg)	MAGNITUDE (ratio)	ANGLE (deg)	
100	0.25122	14.607	9.33681	12.018	0.032124	16.445	0.26458	64.156	1.6
200	0.27070	2.759	9.42458	5.676	0.028303	6.37	0.20645	64.153	1.8
400	0.27979	-7.969	9.63627	-8.447	0.026297	-4.545	0.1543	52.558	1.9
600	0.28323	-14.78	9.76543	-19.02	0.024833	-10.24	0.15203	39.347	1.9
800	0.28557	-20.13	9.93782	-27.93	0.023234	-14.62	0.16867	27.926	2.0
1000	0.28673	-24.14	10.03633	-36.88	0.021523	-17.42	0.19196	19.293	2.1
1200	0.28517	-27.57	10.11638	-46.47	0.019830	-19.83	0.21421	12.703	2.2
1400	0.27902	-29.93	10.26450	-56.05	0.018230	-21.14	0.23292	7.154	2.4
1600	0.26682	-31.81	10.40572	-65.76	0.016902	-21.62	0.24605	2.582	2.5
1800	0.24746	-33.12	10.44088	-76.97	0.015759	-22.32	0.25113	-1.26	2.7
2000	0.21894	-33.8	10.46224	-88.33	0.014310	-22.64	0.24367	-4.817	3.0
2200	0.18164	-32.67	10.45202	-100.3	0.013012	-23.13	0.22184	-7.573	3.4
2400	0.14000	-26.75	10.34342	-112.6	0.011826	-23.27	0.18787	-8.489	3.9
2600	0.10418	-10.16	9.87989	-122.9	0.010171	-23.23	0.13049	-4.601	4.9
2800	0.09469	15.051	9.20393	-129.5	0.008664	-16.9	0.1294	9.578	6.2
3000	0.10595	33.415	8.68177	-135.4	0.007541	-9.957	0.1127	18.402	7.5
3200	0.11609	42.888	8.18809	-142.2	0.006655	-0.835	0.092234	23.406	9.0
3400	0.10827	50.017	7.93039	-151.5	0.006042	12.444	0.059268	26.453	10.3
3600	0.09866	60.967	7.77538	-162.2	0.006205	29.297	0.015829	38.211	10.3
3800	0.08693	80.355	7.33775	-172.6	0.007039	40.351	0.028159	-152.8	9.6
4000	0.10090	102.07	6.90878	177.1	0.008241	46.053	0.075298	-133.1	8.7

MMIC wideband amplifier

BGM1012

PACKAGE OUTLINE

Plastic surface mounted package; 6 leads

SOT363

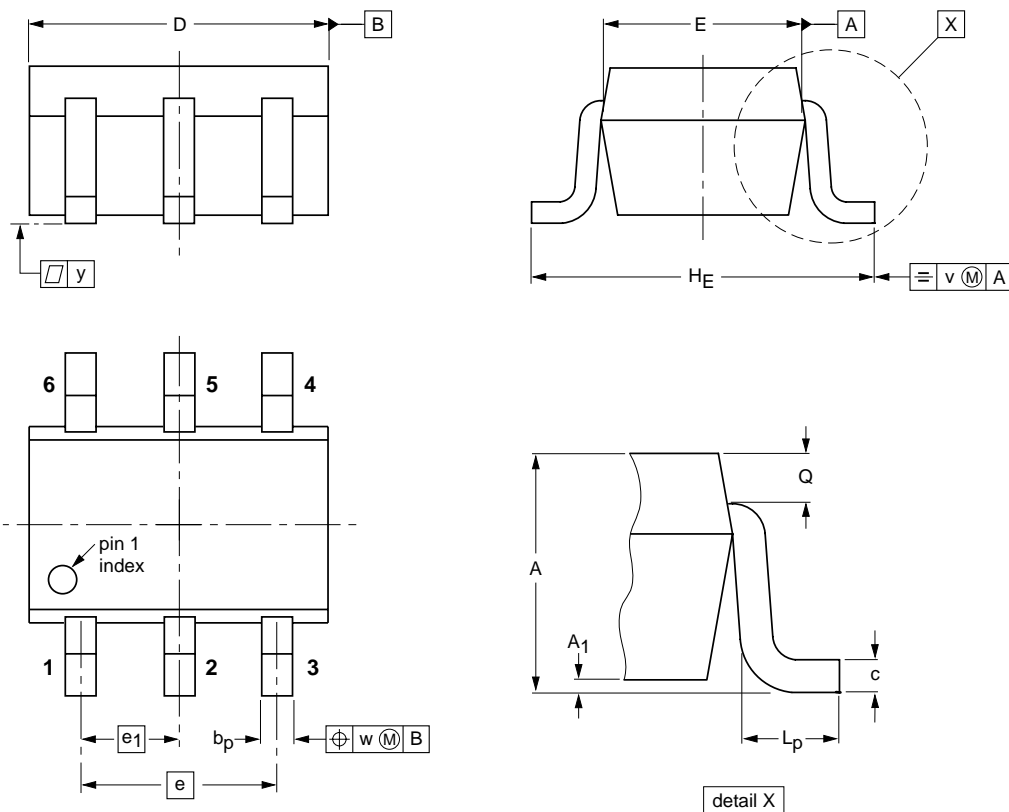

DIMENSIONS (mm are the original dimensions)

UNIT	A	A ₁ max	bp	c	D	E	e	e ₁	H _E	L _p	Q	v	w	y
mm	1.1 0.8	0.1	0.30 0.20	0.25 0.10	2.2 1.8	1.35 1.15	1.3	0.65	2.2 2.0	0.45 0.15	0.25 0.15	0.2	0.2	0.1

OUTLINE VERSION	REFERENCES				EUROPEAN PROJECTION	ISSUE DATE
	IEC	JEDEC	EIAJ			
SOT363			SC-88			97-02-28

MMIC wideband amplifier

BGM1012

DATA SHEET STATUS

DATA SHEET STATUS ⁽¹⁾	PRODUCT STATUS ⁽²⁾	DEFINITIONS
Objective data	Development	This data sheet contains data from the objective specification for product development. Philips Semiconductors reserves the right to change the specification in any manner without notice.
Preliminary data	Qualification	This data sheet contains data from the preliminary specification. Supplementary data will be published at a later date. Philips Semiconductors reserves the right to change the specification without notice, in order to improve the design and supply the best possible product.
Product data	Production	This data sheet contains data from the product specification. Philips Semiconductors reserves the right to make changes at any time in order to improve the design, manufacturing and supply. Changes will be communicated according to the Customer Product/Process Change Notification (CPCN) procedure SNW-SQ-650A.

Notes

1. Please consult the most recently issued data sheet before initiating or completing a design.
2. The product status of the device(s) described in this data sheet may have changed since this data sheet was published. The latest information is available on the Internet at URL <http://www.semiconductors.philips.com>.

DEFINITIONS

Short-form specification — The data in a short-form specification is extracted from a full data sheet with the same type number and title. For detailed information see the relevant data sheet or data handbook.

Limiting values definition — Limiting values given are in accordance with the Absolute Maximum Rating System (IEC 60134). Stress above one or more of the limiting values may cause permanent damage to the device. These are stress ratings only and operation of the device at these or at any other conditions above those given in the Characteristics sections of the specification is not implied. Exposure to limiting values for extended periods may affect device reliability.

Application information — Applications that are described herein for any of these products are for illustrative purposes only. Philips Semiconductors make no representation or warranty that such applications will be suitable for the specified use without further testing or modification.

DISCLAIMERS

Life support applications — These products are not designed for use in life support appliances, devices, or systems where malfunction of these products can reasonably be expected to result in personal injury. Philips Semiconductors customers using or selling these products for use in such applications do so at their own risk and agree to fully indemnify Philips Semiconductors for any damages resulting from such application.

Right to make changes — Philips Semiconductors reserves the right to make changes, without notice, in the products, including circuits, standard cells, and/or software, described or contained herein in order to improve design and/or performance. Philips Semiconductors assumes no responsibility or liability for the use of any of these products, conveys no licence or title under any patent, copyright, or mask work right to these products, and makes no representations or warranties that these products are free from patent, copyright, or mask work right infringement, unless otherwise specified.

Philips Semiconductors – a worldwide company

Contact information

For additional information please visit <http://www.semiconductors.philips.com>. Fax: +31 40 27 24825

For sales offices addresses send e-mail to: sales.addresses@www.semiconductors.philips.com.

© Koninklijke Philips Electronics N.V. 2002

SCA74

All rights are reserved. Reproduction in whole or in part is prohibited without the prior written consent of the copyright owner.

The information presented in this document does not form part of any quotation or contract, is believed to be accurate and reliable and may be changed without notice. No liability will be accepted by the publisher for any consequence of its use. Publication thereof does not convey nor imply any license under patent- or other industrial or intellectual property rights.

Printed in The Netherlands

613516/03/pp12

Date of release: 2002 Sep 06

Document order number: 9397 750 10021

Let's make things better.

**Philips
Semiconductors**



PHILIPS