Features

- Programmable System Clock with Prescaler and Five Different Clock Sources
 - 4-MHz Crystal Oscillator
 - 32-kHz Crystal Oscillator
 - RC-oscillator Fully Integrated
 - RC-oscillator with External Resistor Adjustment
 - External Clock Input
- Wide Supply-voltage Range (2.2 V to 6.2 V)
- Very Low Halt Current ($< 1 \mu\text{A}$)
- 4-Kbyte ROM, 256×4 -bit RAM
- 8 Hard and Software Interrupt Priority Levels
- Up to 10 External and 4 Internal Interrupts, Bit Wise Maskable with Programmable Priority Level
- Up to 34 I/O Lines Including 8 High Drive I/O-lines (20 mA, $V_{DD} = 5 \text{ V}$)
- I/O Ports – Bit Wise Configurable with Combined Interrupt Handling (for Serial I/O Applications)
- 2×8 -bit Multifunction Timer/Counters
- Coded Reset and Watchdog Timer (Mask Option)
- Power-on Reset and “Brown Out” Function
- Various Power-down Modes
- Efficient, Hardware-controlled Interrupt Handling
- High Level Programming Language qFORTH
- Comprehensive Library of Useful Routines
- Windows® 95/Windows NT® Based Development Tools



MARC4 4-bit Universal Microcontroller

ATAR510

Description

The ATAR510 is a member of Atmel's family of 4-bit single-chip microcontrollers. It contains ROM, RAM, up to 34 digital I/O pins, up to 10 maskable external interrupt sources, 4 maskable internal interrupts, a watchdog timer, interval timer, 2 x 8-bit multifunction timer/counter module, and a versatile software configurable on-chip system clock module.



Figure 0-1. Block Diagram

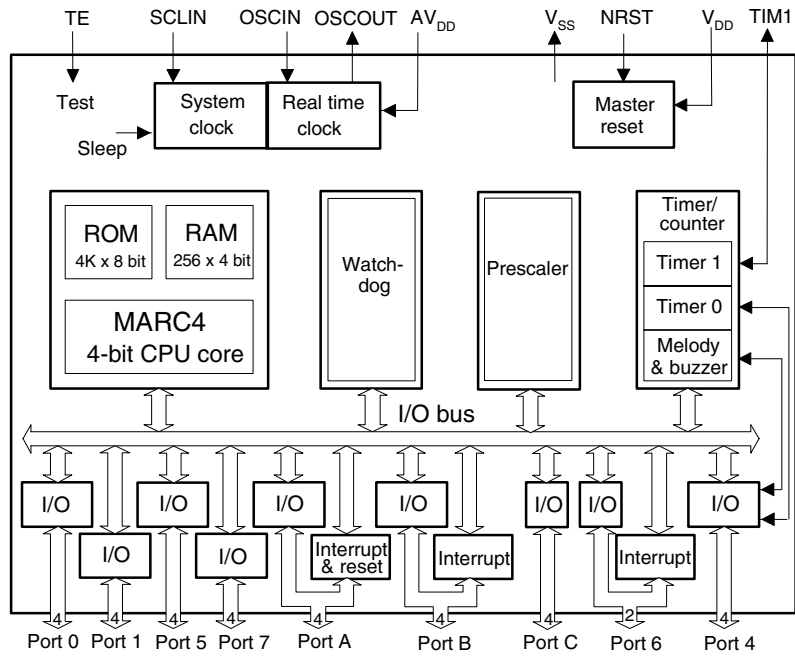

1. Pin Configuration

Figure 1-1. Pinning SSO44

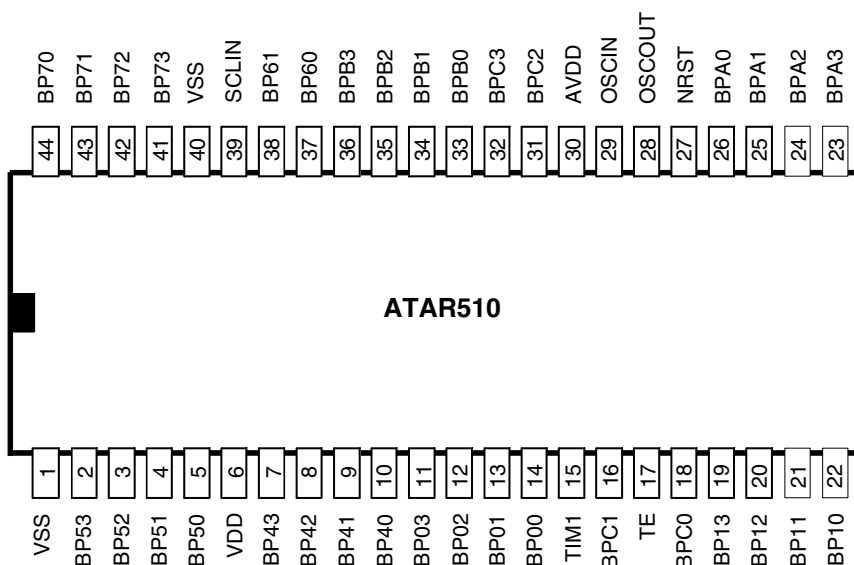

Table 1-1. Pin Description

Pin	Symbol	Function
1	VSS	Circuit ground
2	BP53	I/O line of high current Port 5 ⁽¹⁾ – bit wise configurable
3	BP52	I/O line of high current Port 5 ⁽¹⁾ – bit wise configurable
4	BP51	I/O line of high current Port 5 ⁽¹⁾ – bit wise configurable
5	BP50	I/O line of high current Port 5 ⁽¹⁾ – bit wise configurable
6	VDD	Power supply voltage +2.2 V to +6.2 V
7	BP43 (NBUZ)	High current I/O line BP43 of Port 4 ⁽¹⁾ – configurable or buzzer output NBUZ
8	BP42 (BUZ)	High current I/O line BP42 of Port 4 ⁽¹⁾ – configurable or buzzer output BUZ
9	BP41 (T0OUT1)	I/O line BP41 of Port 4 ⁽¹⁾ – configurable or timer/counter I/O T0OUT1
10	BP40 (T0OUT0)	I/O line BP40 of Port 4 ⁽¹⁾ – configurable or timer/counter I/O T0OUT0
11	BP03	I/O line of Port 0 – automatic nibble wise configurable
12	BP02	I/O line of Port 0 – automatic nibble wise configurable
13	BP01	I/O line of Port 0 – automatic nibble wise configurable
14	BP00	I/O line of Port 0 – automatic nibble wise configurable
15	TIM1	Dedicated I/O for Timer 1
16	BPC1	I/O line of Port C ⁽¹⁾ – bit wise configurable I/O
17	TE	Test mode input, used to control production test modes (internal pull-down)
18	BPC0	I/O line of Port C ⁽¹⁾ – bit wise configurable I/O
19	BP13	I/O line of Port 1 ⁽¹⁾ – automatic nibble wise configurable

Note: 1. For mask options, please see the order information.

Table 1-1. Pin Description (Continued)

Pin	Symbol	Function
20	BP12	I/O line of Port 1 ⁽¹⁾ – automatic nibble wise configurable
21	BP11	I/O line of Port 1 ⁽¹⁾ – automatic nibble wise configurable
22	BP10	I/O line of Port 1 ⁽¹⁾ – automatic nibble wise configurable
23	BPA3	I/O line of Port A ⁽¹⁾ – bit wise configurable, as inputs for port monitor module and optional coded reset inputs ⁽¹⁾
24	BPA2	I/O line of Port A ⁽¹⁾ – bit wise configurable, as inputs for port monitor module and optional coded reset inputs ⁽¹⁾
25	BPA1	I/O line of Port A ⁽¹⁾ – bit wise configurable, as inputs for port monitor module and optional coded reset inputs ⁽¹⁾
26	BPA0	I/O line of Port A ⁽¹⁾ – bit wise configurable, as inputs for port monitor module and optional coded reset inputs ⁽¹⁾
27	NRST	Reset input (/output), a logic low on this pin resets the device. An internal watchdog or coded reset can generate a low pulse on this pin
28	OSCOOUT	32-kHz or 4-MHz quartz crystal output pin
29	OSCIN	32-kHz or 4-MHz quartz crystal input pin
30	AV _{DD}	Analog power supply voltage +2.2 V to +6.2 V
31	BPC2	I/O line of Port C ⁽¹⁾ – bit wise configurable I/O
32	BPC3	I/O line of Port C ⁽¹⁾ – bit wise configurable I/O
33	BPB0	I/O line of Port B ⁽¹⁾ – bit wise configurable I/O and as inputs for port monitor module
34	BPB1	I/O line of Port B ⁽¹⁾ – bit wise configurable I/O and as inputs for port monitor module
35	BPB2	I/O line of Port B ⁽¹⁾ – bit wise configurable I/O and as inputs for port monitor module
36	BPB3	I/O line of Port B ⁽¹⁾ – bit wise configurable I/O and as inputs for port monitor module
37	BP60	I/O line of Port 6 ⁽¹⁾ – bit wise configurable I/O or as external programmable interrupts
38	BP61	I/O line of Port 6 ⁽¹⁾ – bit wise configurable I/O or as external programmable interrupts
39	SCLIN	External trimming resistor or external clock input
40	VSS	Supply voltage
41	BP73	I/O line of high current Port 7 ⁽¹⁾ – bit wise configurable
42	BP72	I/O line of high current Port 7 ⁽¹⁾ – bit wise configurable
43	BP71	I/O line of high current Port 7 ⁽¹⁾ – bit wise configurable
44	BP70	I/O line of high current Port 7 ⁽¹⁾ – bit wise configurable

Note: 1. For mask options, please see the order information.

2. MARC4 Architecture

2.1 General Description

The MARC4 microcontroller consists of an advanced stack-based 4-bit CPU core and on-chip peripherals. The CPU is based on the Harvard architecture with physically separate program memory (ROM) and data memory (RAM). Three independent buses, the instruction bus, the memory bus and the I/O bus, are used for parallel communication between ROM, RAM and peripherals. This enhances program execution speed by allowing both instruction prefetching, and a simultaneous communication to the on-chip peripheral circuitry. The extremely powerful integrated interrupt controller with associated eight prioritized interrupt levels supports fast and efficient processing of hardware events. The MARC4 is designed for the high-level programming language qFORTH. The core includes both an expression and a return stack. This architecture enables high-level language programming without any loss of efficiency or code density.

Figure 2-1. MARC4 Core

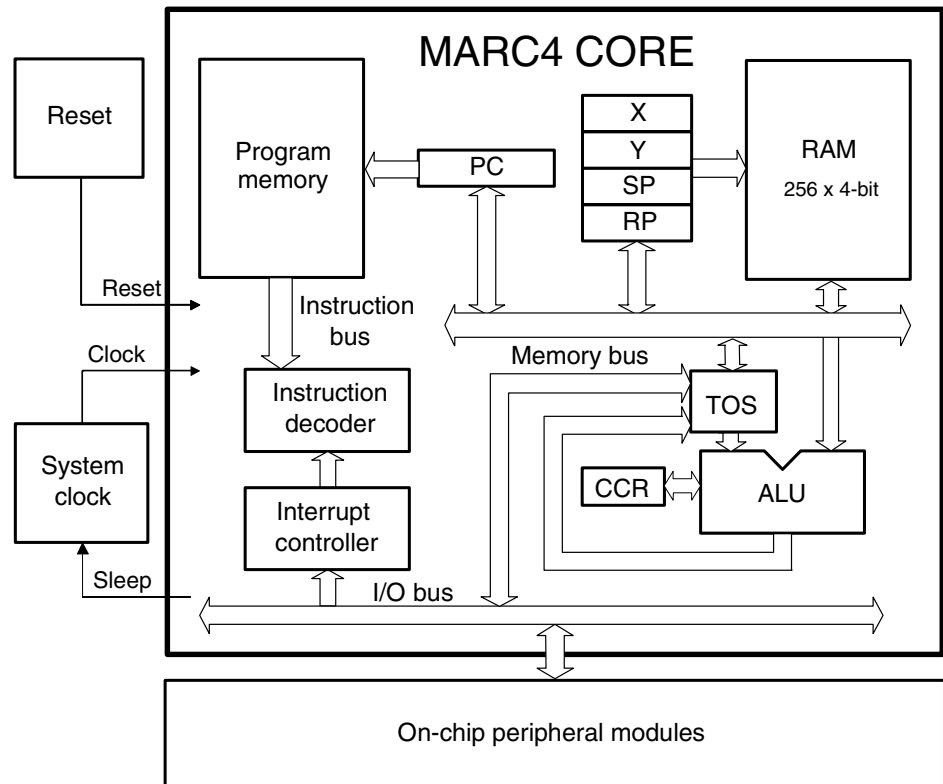

2.2 Components of MARC4 Core

The core contains ROM, RAM, ALU, a program counter, RAM address registers, an instruction decoder and an interrupt controller. The following sections describe each functional block in more detail.

2.2.1 ROM

The program memory (ROM) is mask programmed with the customer application program during the fabrication of the microcontroller. The ROM is addressed by a 12-bit wide program counter, thus predefining a maximum program bank size of 4 Kbytes. An additional 1 Kbyte of ROM exists which is used partly for a quality control self-test program. The remaining space is available for the application program. The access to this additional ROM section is done by using a ROM-bank switch.

The lowest user ROM address segment is taken up by a 512-byte zero page which contains predefined start addresses for interrupt service routines and special subroutines accessible with single byte instructions (SCALL). The corresponding memory map is shown in Figure 2-2. Look-up tables of constants can also be held in ROM and are accessed via the MARC4's built-in table instruction.

2.2.1.1 ROM Banking

Bank switching is fully supported by the compiler for customers programming with qFORTH. The MARC4 switches from one ROM bank to another by writing the new bank number to the ROM Bank Register (RBR). Conventional program space (power-up bank) resides in ROM bank 0. Each ROM bank consists of a 4-Kbyte address space whereby the lowest 2 Kbyte is common to all banks, so that addresses between 000h and 7FFh always accesses the same ROM data (see Figure 2-2). When ROM banking is used, the compiler will, if necessary, insert the program code to save and restore the condition of the RBR on bank switching.

Figure 2-2. ROM Map

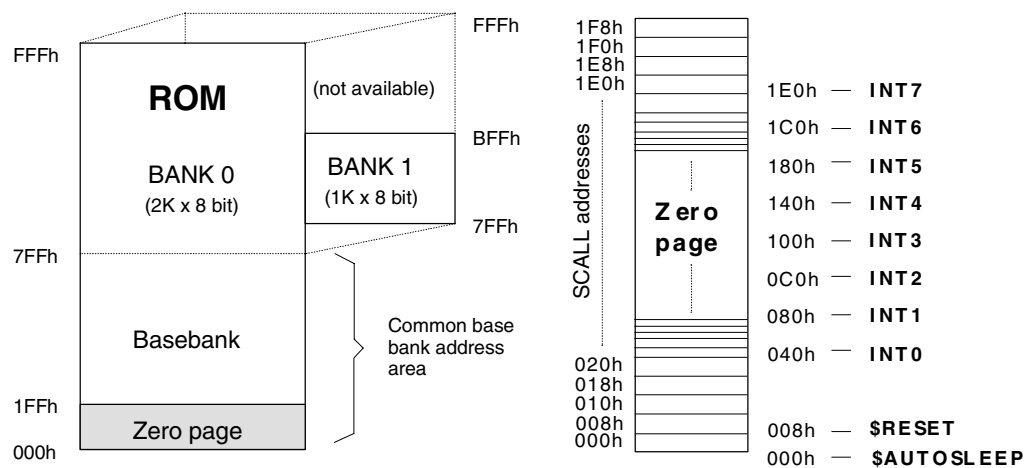

2.2.2 RAM

The MARC4 contains 256 x 4-bit wide static random access memory (RAM). It is used for the expression stack, the return stack and data memory for variables and arrays. The RAM is addressed by any of the four 8-bit wide RAM address registers SP, RP, X and Y.

Figure 2-3. RAM Map

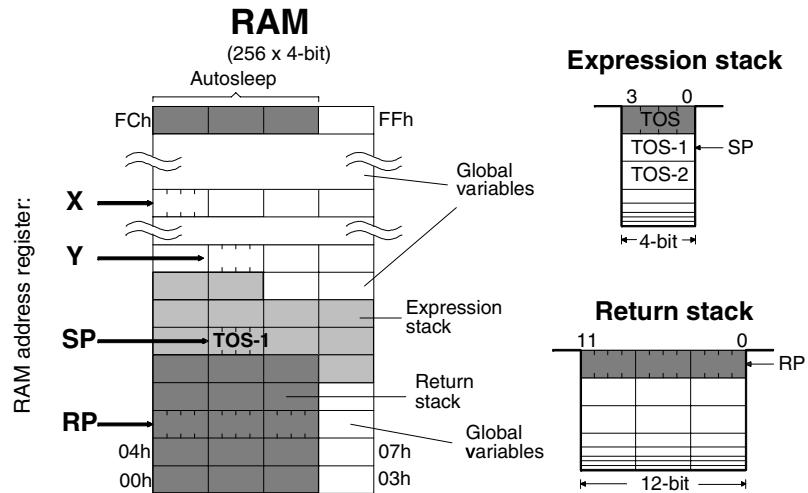

2.2.2.1 Expression Stack

The 4-bit wide expression stack is addressed with the expression stack pointer (SP). All arithmetic, I/O and memory reference operations take their operands from, and return their results to the expression stack. The MARC4 performs the operations with the top of stack items (TOS and TOS-1). The TOS register contains the top element of the expression stack and works in the same way as an accumulator. This stack is also used for passing parameters between subroutines and as a scratch pad area for temporary storage of data.

2.2.2.2 Return Stack

The 12-bit wide return stack is addressed by the return stack pointer (RP). It is used for storing return addresses of subroutines, interrupt routines and for keeping loop index counts. The return stack can also be used as a temporary storage area.

The MARC4 instruction set supports the exchange of data between the top elements of the expression stack and the return stack. The two stacks, within the RAM, have a user definable location and maximum depth.

2.2.3 Registers

The MARC4 controller has seven programmable registers and one condition code register. They are shown in the following programming model.

2.2.3.1 Program Counter (PC)

The program counter is a 12-bit register which contains the address of the next instruction to be fetched from the ROM. Instructions currently being executed are decoded in the instruction decoder to determine the internal micro-operations. For linear code (no calls or branches) the program counter is incremented with every instruction cycle. If a branch, call, return instruction or an interrupt is executed, the program counter is loaded with a new address. The program counter is also used with the table instruction to fetch 8-bit wide ROM constants.

Figure 2-4. Programming Model

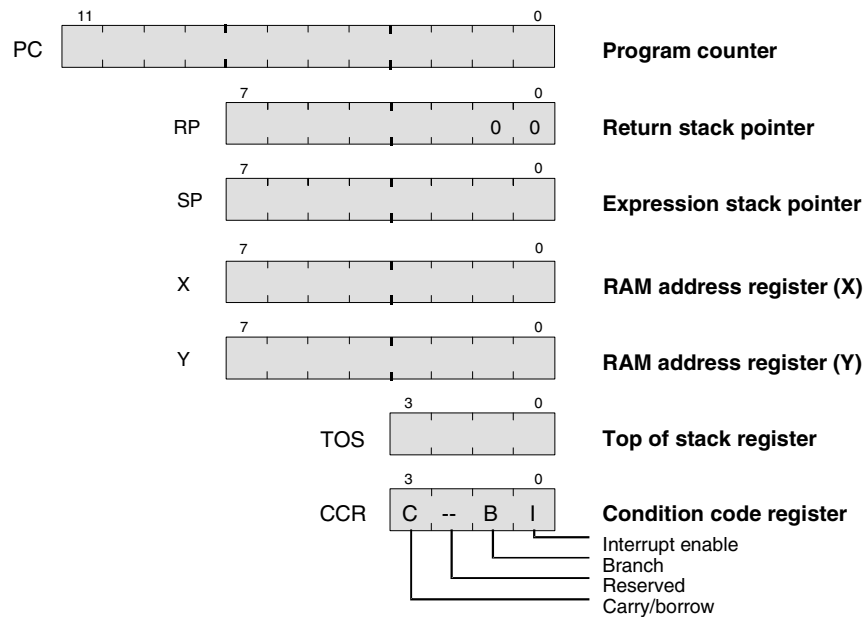

2.2.3.2 ROM Banking Register (RBR)

The ROM banking register is a 4-bit register whereby in the ATAR510, only bit 2 is used. This indicates which ROM bank is presently being addressed. The RBR is accessed with a standard qFORTH peripheral read or write instruction (IN or OUT, port address 'D' hex).

2.2.3.3 RAM Address Registers

The RAM is addressed with the four 8-bit wide RAM address registers: SP, RP, X and Y. These registers allow access to any of the 256 RAM nibbles.

2.2.3.4 Expression Stack Pointer (SP)

The stack pointer contains the address of the next-to-top 4-bit item (TOS-1) of the expression stack. The pointer is automatically pre-incremented if a nibble is moved onto the stack or post-decremented if a nibble is removed from the stack. Every post-decrement operation moves the item (TOS-1) to the TOS register before the SP is decremented. After a reset the stack pointer has to be initialized with >SP S0 to allocate the start address of the expression stack area.

2.2.3.5 Return Stack Pointer (RP)

The return stack pointer points to the top element of the 12-bit wide return stack. The pointer automatically pre-increments if an element is moved onto the stack, or it post-decrements if an element is removed from the stack. The return stack pointer increments and decrements in steps of 4. This means that every time a 12-bit element is stacked, a 4-bit RAM location is left unwritten. This location is used by the qFORTH compiler to allocate 4-bit variables. After a reset the return stack pointer has to be initialized via >RP FCh.

2.2.3.6 RAM Address Registers (X and Y)

The X and Y registers are used to address any 4-bit item in the RAM. A fetch operation moves the addressed nibble onto the TOS. A store operation moves the TOS to the addressed RAM location. By using either the pre-increment or post-decrement addressing mode arrays in the RAM can be compared, filled or moved.

2.2.3.7 Top of Stack (TOS)

The top of stack register is the accumulator of the MARC4. All arithmetic/logic, memory reference and I/O operations use this register. The TOS register receives data from the ALU, ROM, RAM or I/O bus.

2.2.3.8 Condition Code Register (CCR)

The 4-bit wide condition code register contains the branch, the carry and the interrupt enable flag. These bits indicate the current state of the CPU. The CCR flags are set or reset by ALU operations. The instructions SET_BCF, TOG_BF, CCR! and DI allow direct manipulation of the condition code register.

2.2.3.9 Carry/Borrow (C)

The carry/borrow flag indicates that the borrow or carry out of the Arithmetic Logic Unit (ALU) occurred during the last arithmetic operation. During shift and rotate operations, this bit is used as a fifth bit. Boolean operations have no effect on the C-flag.

2.2.3.10 Branch (B)

The branch flag controls the conditional program branching. Should the branch flag have been set by a previous instruction, a conditional branch will cause a jump. This flag is affected by arithmetic, logic, shift, and rotate operations.

2.2.3.11 Interrupt Enable (I)

The interrupt enable flag globally enables or disables the triggering of all interrupt routines with the exception of the non-maskable reset. After a reset or while executing the DI instruction, the interrupt enable flag is reset, thus disabling all interrupts. The core will not accept any further interrupt requests until the interrupt enable flag has been set again by either executing an EI or SLEEP instruction.

2.2.4 ALU

The 4-bit ALU performs all the arithmetic, logical, shift and rotate operations with the top two elements of the expression stack (TOS and TOS-1) and returns the result to the TOS. The ALU operations affect the carry/borrow and branch flag in the condition code register (CCR).

Figure 2-5. ALU Zero-address Operations

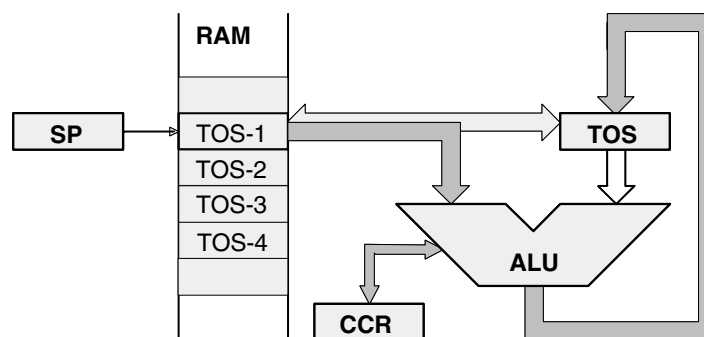

2.2.5 Instruction Set

The MARC4 instruction set is optimized for the high level programming language qFORTH. Many MARC4 instructions are qFORTH words. This enables the compiler to generate a fast and compact program code. The CPU has an instruction pipeline allowing the controller to prefetch an instruction from ROM at the same time as the present instruction is being executed. The MARC4 is a zero-address machine, the instructions contain only the operation to be performed and no source or destination address fields. The operations are implicitly performed on the data placed on the stack. There are one and two byte instructions which are executed within 1 to 4 machine cycles. A MARC4 machine cycle is made up of two system clock cycles (SYSCL). Most of the instructions are only one byte long and are executed in a single machine cycle. For more information refer to the “MARC4 Programmer’s Guide”.

2.2.6 I/O Bus

The I/O ports and the registers of the peripheral modules are I/O mapped. All communication between the core and the on-chip peripherals takes place via the I/O bus and the associated I/O control. With the MARC4 IN and OUT instructions the I/O bus allows a direct read or write access to one of the 16 primary I/O addresses. More about the I/O access to the on-chip peripherals is described in the section “Peripheral Modules”. The I/O bus is internal and is not accessible by the customer on the final microcontroller device, but it is used as the interface for the MARC4 emulation (see also the section “Emulation”).

2.3 Interrupt Structure

The MARC4 can handle interrupts with eight different priority levels. They can be generated from the internal and external interrupt sources or by a software interrupt from the CPU itself. Each interrupt level has a hard-wired priority and an associated vector for the service routine in the ROM (see Table 2-1 on page 11). The programmer can postpone the processing of interrupts by resetting the interrupt enable flag (I) in the CCR. An interrupt occurrence will still be registered, but the interrupt routine only started after the I flag is set. All interrupts can be masked, and the priority individually software configured by programming the appropriate control register of the interrupting module (see section “Peripheral Modules”).

2.3.1 Interrupt Processing

For processing the eight interrupt levels, the MARC4 includes an interrupt controller with two 8-bit wide interrupt pending and interrupt active registers. The interrupt controller samples all interrupt requests during every non-I/O instruction cycle and latches these in the interrupt pending register. Whenever an interrupt request is detected, the CPU interrupts the program currently being executed, on condition that no higher priority interrupt is present in the interrupt active register. If the interrupt enable bit is set, the processor enters an interrupt acknowledge cycle. During this cycle a short call (SCALL) instruction to the service routine is executed and the current PC is saved on the return stack.

An interrupt service routine is completed with the RTI instruction. This instruction resets the corresponding bits in the interrupt pending/active register and fetches the return address from the return stack to the program counter. When the interrupt-enable flag is reset (triggering of interrupt routines are disabled), the execution of new interrupt service routines is inhibited but not the logging of the interrupt requests in the interrupt pending register. The execution of the interrupt is delayed until the interrupt-enable flag is set again. Note that interrupts are only lost if an interrupt request occurs while the corresponding bit in the pending register is still set (i.e., the interrupt service routine is not yet finished).

2.3.2 Interrupt Latency

The interrupt latency is the time from the occurrence of the interrupt to the interrupt service routine being activated. In MARC4 this is extremely short (taking between 3 to 5 machine cycles depending on the state of the core).

Figure 2-6. Interrupt Handling

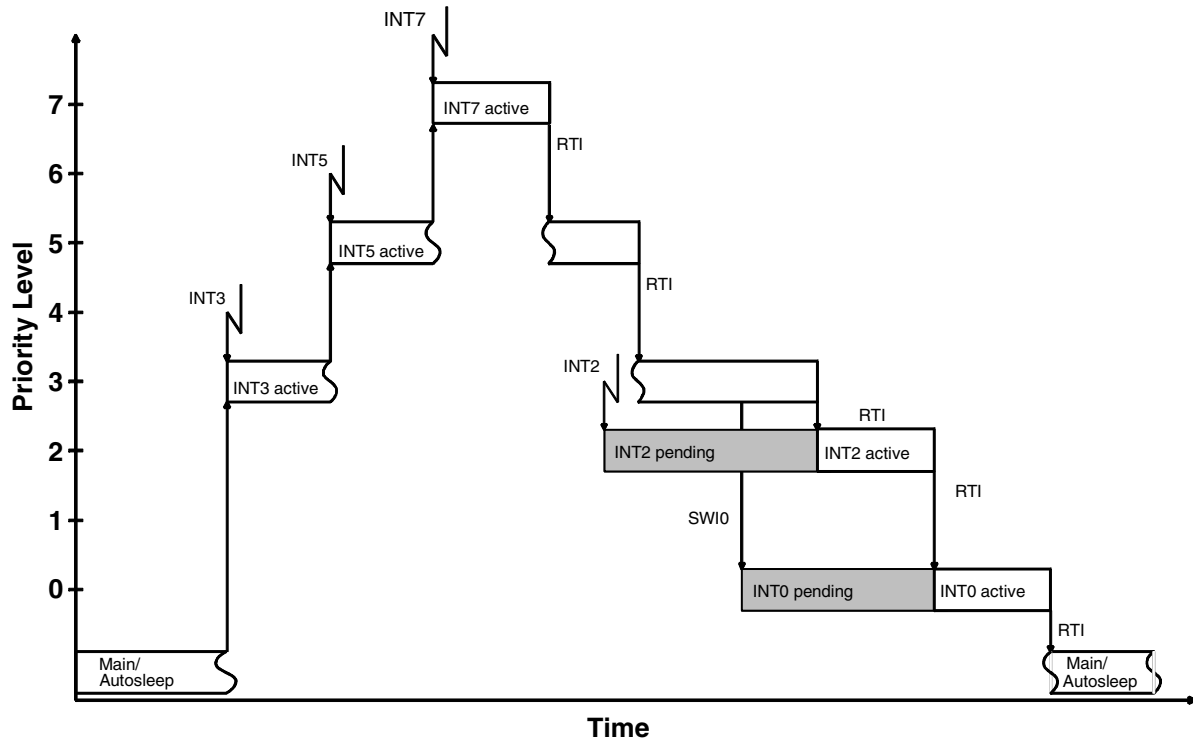

Table 2-1. Interrupt Priority Table

Interrupt	Priority	ROM Address	Maskable	Interrupt Opcode
INT0	Lowest	040h	Yes	C8h (SCALL 040h)
INT1		080h	Yes	D0h (SCALL 080h)
INT2		0C0h	Yes	D8h (SCALL 0C0h)
INT3		100h	Yes	E8h (SCALL 100h)
INT4		140h	Yes	E8h (SCALL 140h)
INT5		180h	Yes	F0h (SCALL 180h)
INT6		1C0h	Yes	F8h (SCALL 1C0h)
INT7	Highest	1E0h	Yes	FCh (SCALL 1E0h)

Table 2-2. Hardware Interrupts

Interrupt Source	Possible Interrupt Priorities								RST	Interrupt Mask		Function
	0	1	2	3	4	5	6	7		Register	Bit	
NRST external									X	–	–	Low level active
Watchdog									#	–	–	1/2 to 2 s time out
Port A coded reset									#	–	–	Level any inputs
Port A monitor		*		*		*		*		PAIPR	3	Any edge, any input
Port B monitor		*		*		*		*		PBIPR	3	Any edge, any input
Port 60 external		*		*		*		*		P6CR	1.0	Any edge
Port 61 external	*		*		*		*			P6CR	3.2	Any edge
Interval timer INTA		*				*				ITIPR	0	1 of 8 frequencies (8 to 128 Hz)
Interval timer INTB			*				*			ITIPR	1	1 of 8 frequencies (8 to 8192 Hz)
Timer 0		*		*		*		*		T0CR	0	Overflow/compare/ End measurement
Timer 1	*		*		*		*			T1CR	0	Compare

- Notes:
1. X = Hardwired (neither optional or software configurable)
 2. # = Customer mask option (see “Ordering Information”)
 3. * = Software configurable (see section “Peripheral Modules” for further details)

In the ATAR510, there are eleven hardware interrupt sources which can be programmed to occupy a variety of priority levels. With the exception of the reset sources (RST), each source can be individually masked by mask bits in the corresponding control registers. An overview of the possible hardware configurations is shown in Table 2-2.

2.3.3 Software Interrupts

The programmer can generate interrupts by using the software interrupt instruction (SWI) which is supported in qFORTH by predefined macros named SWI0 to SWI7. The software triggered interrupt operates exactly like any hardware triggered interrupt. The SWI instruction takes the top two elements from the expression stack and writes the corresponding bits via the I/O bus to the interrupt pending register. Therefore, by using the SWI instruction, interrupts can be re-prioritized or lower priority processes scheduled for later execution.

2.4 Master Reset

The master reset forces the CPU into a well-defined condition. It is unmaskable and is activated independent of the current program state. It can be triggered by either initial supply power-up, a short collapse of the power supply, a watchdog time-out, activation of the NRST input, or the occurrence of a coded reset on Port A (see Figure 2-7 on page 13).

A master reset activation will reset the interrupt enable flag, the interrupt pending registers the interrupt active registers and initializes all on-chip peripherals.

When the reset condition disappears, the CPU remains reset for a further reset delay time (approximately 80 ms), after which it continues with a short call instruction (opcode C1h) to the ROM address 008h. This activates the initialization routine \$RESET which in turn initializes all necessary RAM variables, stack pointers and peripheral configuration registers.

Figure 2-7. Reset Configuration

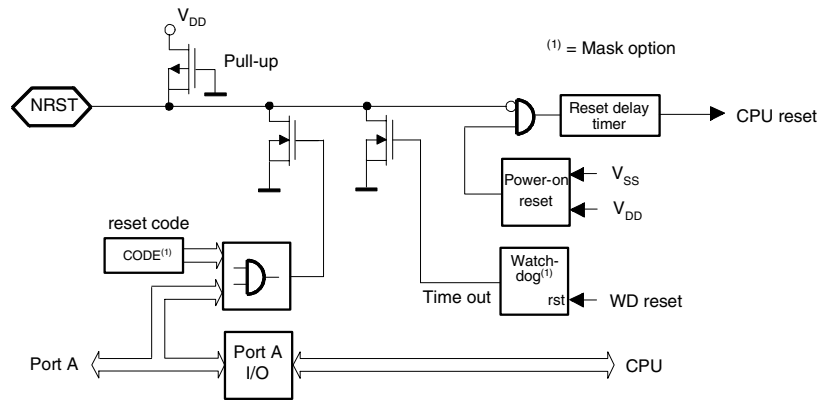

2.4.1 Power-on Reset

The fully integrated power-on reset circuit ensures that the core is held in a reset state until the minimum operating supply voltage has been reached. A reset condition is also generated should the supply voltage drop momentarily below the minimum operating supply.

2.4.2 External Reset (NRST)

An external reset can be triggered with the NRST pin. To activate an external reset, the pin should be low for a minimum of 4 μ s.

2.4.3 Coded Reset (Port A)

The coded reset circuit is connected directly to Port A terminals. By using a mask option, the user can define a hardwired code combination (e.g., all pins low) which, if occurring on Port A, will generate a reset in the same way as the NRST pin.

Table 2-3. Multiple Key Reset Options

NO_RST	Not used (default)
RST2	BPA0 and BPA1 = low
RST3	BPA0 and BPA1 and BPA2 = low
RST4	BPA0 and BPA1 and BPA2 and BPA3 = low
RST5	BPA0 and BPA1 = high
RST6	BPA0 and BPA1 and BPA2 = high
RST7	BPA0 and BPA1 and BPA2 and BPA3 = high

Note: If this option is used, the reset is not maskable and will also trigger if the predefined code is written on to Port A by the CPU itself. Care should also be taken not to generate an unwanted reset by inadvertently passing through the reset code on input transitions. This applies especially if the pins have a high capacitive load.

2.4.4 Watchdog Reset

The watchdog's function can be enabled via a mask option and triggers a reset with every watchdog counter overflow. To suppress the watchdog reset, the counter must be regularly reset by reading the watchdog register address (CWD). The CPU reacts in exactly the same manner as a reset stimulus from any of the above sources.

2.5 Clock Generation

2.5.1 Clock Module

The clock module generates two clocks. The system clock (SYSCL) supplies the CPU and the peripherals while the lower frequency periphery sub-clock (SUBCL) supplies only the peripherals. The modes for clock sources are programmable with the OS1-bit and OS0 bit in the SC register and the CCS-bit in the CM-register.

The ATAR510 contains a clock module with 4 different internal oscillator types: two RC-oscillators, one 4-MHz crystal oscillator and one 32-kHz crystal oscillator. The pins OSC1 and OSC2 provide the interface to connect a crystal either to the 4-MHz, or to the 32-kHz crystal oscillator. SCLIN can be used as an input for an external clock or to connect an external trimming resistor for the RC-oscillator 2. All necessary components with the exception of the crystal and the trimming resistor is integrated on-chip. Any one of these clock sources can be selected to generate the system clock (SYSCL).

In applications that do not require exact timing, it is possible to use the fully integrated RC-oscillator 1 without any external components. The RC-oscillator 2 is more stable but the oscillator frequency must be trimmed with an external resistor attached between SCLIN and V_{DD} . In this configuration, for system clock frequencies below 2 MHz, the RC-oscillator 2 frequency can be maintained stable with a tolerance of $\pm 10\%$ over the full operating temperature and voltage range.

The clock module is software programmable using the clock management register (CM) and the system configuration register (SC). The required oscillator configuration can be selected with the OS(1:0)-bits in the SC-register. A programmable 4-bit divider stage allows the adjustment of the system clock speed. A synchronization stage avoids any clock glitches which could be caused by clock source switching.

The CPU always requires SYSCL clocks to execute instructions, process interrupts and enter or leave the SLEEP state. Internal oscillators are, depending on the condition of the NSTOP-bit automatically stopped and started where necessary. Special care must however be taken when using an external clock source which is gated by one of the microcontroller port signals. This configuration can hang up if the external oscillator is switched off while the external clock source is still selected. It is therefore advisable in such a case to switch first to the internal RC-oscillator 1 source using the CSS-bit. The external source can then be reselected later when the external oscillator has again been restarted.

Figure 2-8. Clock Module

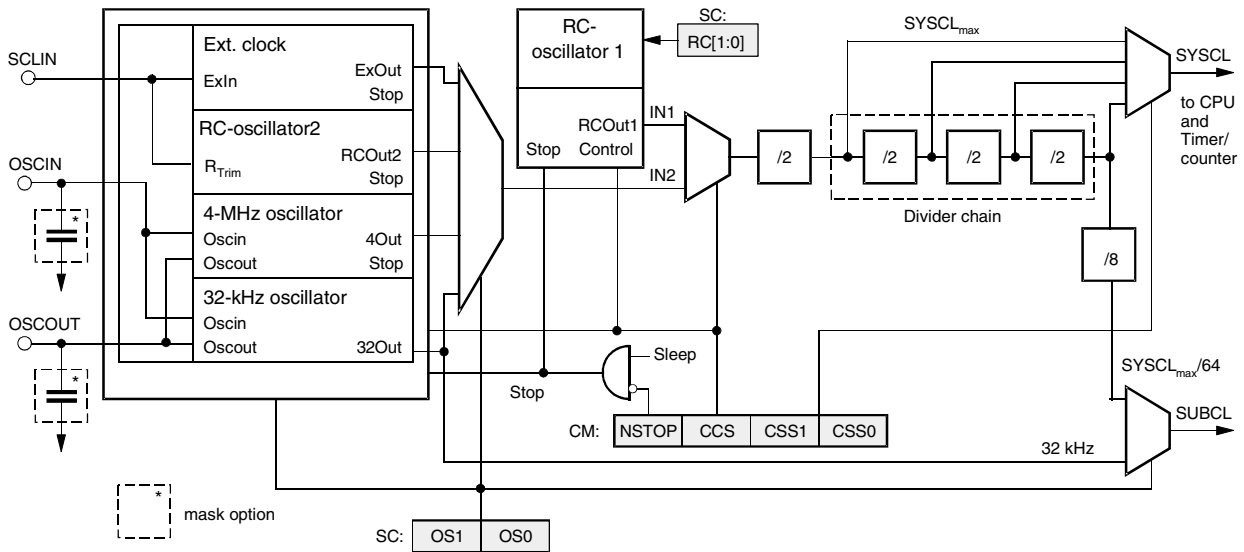

Table 2-4. Clock Modes

Mode	OS1	OS0	Clock Source for SYCSL		Clock Source for SUBCL	
			CCS = 1	CCS = 0	CCS = 1	CCS = 0
1	1	1	RC-oscillator 1 (internal)	External input clock	SYCSL _{max} /64	SCLIN/128
2	0	1	RC-oscillator 1 (internal)	RC-oscillator 2 with external trimming resistor	SYCSL _{max} /64	SYCSL _{max} /64
3	1	0	RC-oscillator 1 (internal)	4-MHz oscillator	SYCSL _{max} /64	f _{X TAL} /128
4	0	0	RC-oscillator 1 (internal)	32-kHz oscillator	32 kHz	

2.5.2 Oscillator Circuits and External Clock Input Stage

2.5.2.1 RC-oscillator 1 Fully Integrated

For timing insensitive applications, it is possible to use the fully integrated RC-oscillator 1. It operates without any external components and saves additional costs. The RC-oscillator 1 center frequency tolerance is better than $\pm 50\%$ over the full temperature and voltage range. A reduction in the application operating supply voltage and temperature ranges will result in improved frequency tolerance. For more detailed information see Figure 7-8 on page 64 - Figure 7-10 on page 64. The basic center frequency of the RC-oscillator 1 is programmable with the RC1 and the RC0-bits in the SC-register.

Figure 2-9. RC-oscillator 1

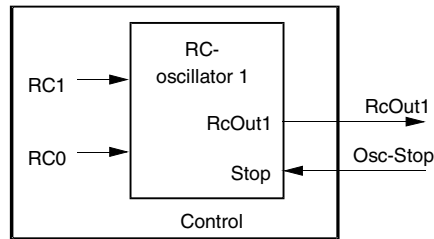

2.5.2.2 External Input Clock

The SCLIN pin can be driven by an external clock source provided it meets the specified duty cycle, rise and fall times and input levels. The maximum system clock frequency $f_{\text{SYSCL}_{\text{max}}}$ that the core can operate is $f_{\text{SCLIN}}/2$ (see Figure 2-8 on page 15).

Figure 2-10. External Input Clock

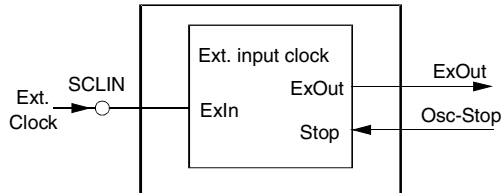

2.5.2.3 RC-oscillator 2 with External Trimming Resistor

The RC-oscillator 2 is a high stability oscillator whereby the oscillator frequency can be trimmed with an external resistor between SCLIN and V_{DD} . In this configuration, as long as the system clock frequency does not exceed 2 MHz, the RC-oscillator 2 frequency can be maintained stable with a tolerance of $\pm 10\%$ over the full operating temperature and voltage range.

For example: A $\text{SYSCL}_{\text{max}}$ frequency of 2 MHz, can be obtained by connecting a resistor $R_{\text{ext}} = 150 \text{ k}\Omega$ (see Figure 2-11, Figure 7-5 on page 63 - Figure 7-7 on page 63).

Figure 2-11. RC-oscillator 2

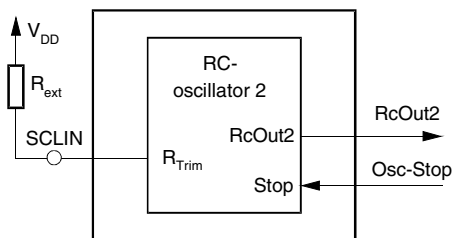

2.5.2.4 4-MHz Oscillator

The integrated system clock oscillator requires an external crystal or ceramic resonator connected between the OSCIN and OSCOUT pins to establish oscillation. All the necessary oscillator circuitry, with the exception of the actual crystal, resonator and the optional C_3 and C_4 are integrated on-chip.

Figure 2-12. System Clock Oscillator

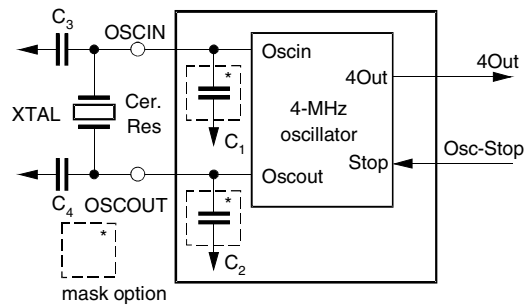

2.5.2.5 32-kHz Oscillator

Some applications require accurate long-term time keeping without putting excessive demands on the CPU or alternatively low resolution computing power. In this case, the on-chip ultra low power 32-kHz crystal oscillator can be used to generate both the SUBCL and/or the SYSCl. In this mode, power consumption can be significantly reduced. The 32-kHz crystal oscillator will key operating (not stopped) during any CPU power-down/SLEEP mode.

Figure 2-13. 32-kHz Crystal Oscillator

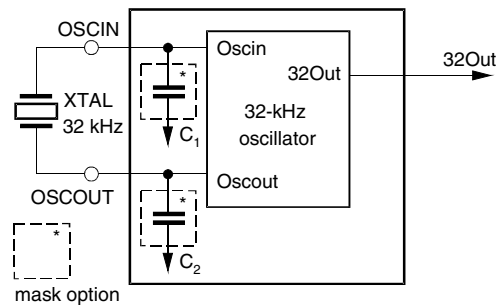

Note: Both, the 4-MHz and the 32-kHz crystal oscillator, use an integrated 14 stage divider circuit to stabilize oscillation before the oscillator output is used as system clock. This results in an additional delay of about 4 ms for the 4-MHz crystal and about 500 ms for the 32-kHz crystal.

2.5.3 Clock Management

The clock management register controls the system clock divider and synchronization stage. Writing to this register triggers the synchronization cycle.

2.5.3.1 Clock Management Register (CM)

Auxiliary register address: 'E'hex

	Bit 3	Bit 2	Bit 1	Bit 0	
CM	NSTOP	CCS	CSS1	CSS0	Reset value: 1111b

NSTOP	<p>Not STOP peripheral clock</p> <p>NSTOP = 0, stops the peripheral clock while the core is in SLEEP mode The 32-kHz crystal oscillator SUBCL clock cannot be stopped</p> <p>NSTOP = 1, enables the peripheral clock while the core is in SLEEP mode</p>
CCS	<p>Core Clock Select</p> <p>CCS = 1, the internal RC-oscillator 1 generates SYSCL</p> <p>CCS = 0, the 4-MHz crystal oscillator, the 32-kHz crystal oscillator, an external clock source or the RC-oscillator 2 (with the external resistor) will generate SYSCL dependent on the setting of OS0 and OS1 in the system configuration register</p>
CSS1 (1:0)	<p>Core Speed Select</p> <p>These two bits control the system clock divider chain</p>

Table 2-5. Core Speed Select

CSS1	CSS0	Divider	Note
0	0	16	$SYSC_{L_{max}}/8$
0	1	8	$SYSC_{L_{max}}/4$
1	0	4	$SYSC_{L_{max}}/2$
1	1	2	Reset value = $SYSC_{L_{max}}$

2.5.3.2 System Configuration Register (SC)

Primary register address: 'E'hex

	Bit 3	Bit 2	Bit 1	Bit 0	
SC: write	RC1	RC0	OS1	OS0	Reset value: 1111b

Table 2-6. Internal RC Oscillator 1 Frequency Selection ($SYSC_{L_{max}}$)

RC1	RC0	$SYSC_{L_{max}}$ at 25°C, $V_{DD} = 5 V$	Note
0	0	7.0 MHz (f_{iRC0})	–
0	1	3.0 MHz (f_{iRC1})	–
1	0	2.0 MHz (f_{iRC2})	–
1	1	0.8 MHz (f_{iRC3})	Reset value

OS1, OS0 Oscillator selection bits (in conjunction with the CCS-bit)

Table 2-7. Oscillator Select

CCS	OS1	OS0	SUBCL	System Oscillator Selection
0	1	1		External input clock at SCLIN
0	0	1	SYSC _{Lmax} /64	RC-oscillator 2 with R _{ext}
0	1	0		4-MHz crystal oscillator
0	0	0	32 kHz	32-kHz crystal oscillator
1	x	x	SYSC _{Lmax} /64 or 32 kHz	RC-oscillator 1

Note: If the bit CCS = 0 in the CM-register, the RC-oscillator 1 is stopped.

2.5.4 Power-down Modes

The ATAR510 incorporates several modes which enable the power consumption to be tailored to a minimum without sacrificing computational power. When the controller exits the lowest priority interrupt task, it reverts to a SLEEP state. This is a CPU shutdown condition which is used to reduce average system power consumption where the CPU itself is only partially utilized. In SLEEP, the CPU clocking system is deactivated whereby the peripherals and associated clock sources may remain active (Standby Mode) or they can also be halted (Halt Mode). In Standby Mode, the peripherals are able to continue operation and if required also generate interrupts which can, along with a reset reactivate the CPU to bring it out of the sleep state.

SLEEP can only be maintained when none of the interrupt pending or active register bits are set. The application of the \$AUTOSLEEP routine ensures the correct function of the sleep mode.

In both Standby and Active modes the current consumption is largely dependent on the frequency of the CPU system clock (SYSC_L) and the supply voltage (V_{DD}) (see Figure 7-3 on page 62 and Figure 7-4 on page 62) while the Halt Mode current is merely controller static leakage current.

Selection of Standby or Halt mode is performed by the NSTOP bit in the clock management register (CM). It should be noted that the low power 32-kHz crystal oscillator, if enabled will always remain active in both Standby and Halt modes.

Table 2-8. Power-down Modes

Mode	CPU Core State	NSTOP	RC-Oscillator 1 RC-Oscillator 2 4-MHz Oscillator	32-kHz Oscillator	External Input Clock at SCLIN
Active	RUN	1	RUN	RUN	Enabled
Standby	SLEEP	1	RUN	RUN	Enabled
Halt	SLEEP	0	STOP	RUN	Disabled

2.5.5 Clock Monitor Mode

Figure 2-14. Clock Monitoring

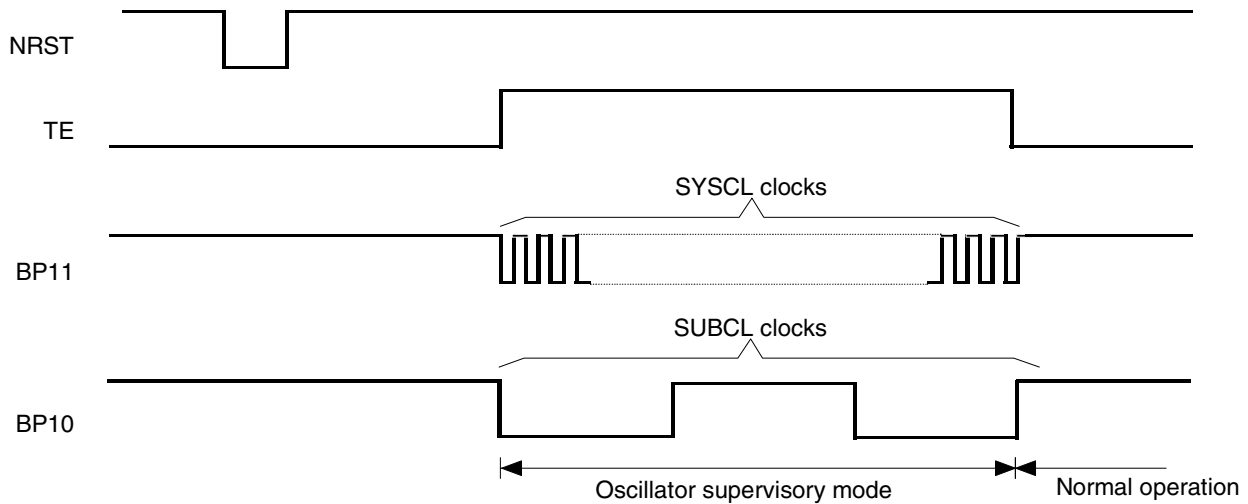

For trimming purposes, the ATAR510 can be put into a clock monitor mode. By forcing the test input (TE) high, the SYSCL clock will appear on BP11 (Port 1, bit 1) and SUBCL clock on Port BP10 (Port 1, bit 0). On releasing the TE pin, the BP10 and BP11 will resume their normal function (see Figure 2-14).

3. Peripheral Modules

3.1 Addressing Peripherals

Accessing the peripheral modules takes place via the I/O bus (see Figure 3-1 on page 21). The IN or OUT instructions allow direct addressing of up to 16 I/O modules. A dual register addressing scheme has been adopted which addresses the “primary register” directly. To address the auxiliary register, the access must be switched with an “auxiliary switching module”. Thus, a single IN (or OUT) to the module address will read (or write) into the module primary register. Accessing the auxiliary register is performed with the same instruction preceded by writing the module address into the auxiliary switching module. Byte-wide registers are accessed by multiple IN (or OUT) instructions. Extended addressing is used for more complex peripheral modules, with a larger number of registers. In this case, a bank of up to 16 support registers are indirectly addressed with the support address being initially written into the auxiliary register. Please refer to the 'HARDC510.SCR' hardware interface file as a programming guideline.

Figure 3-1. Example of I/O Addressing

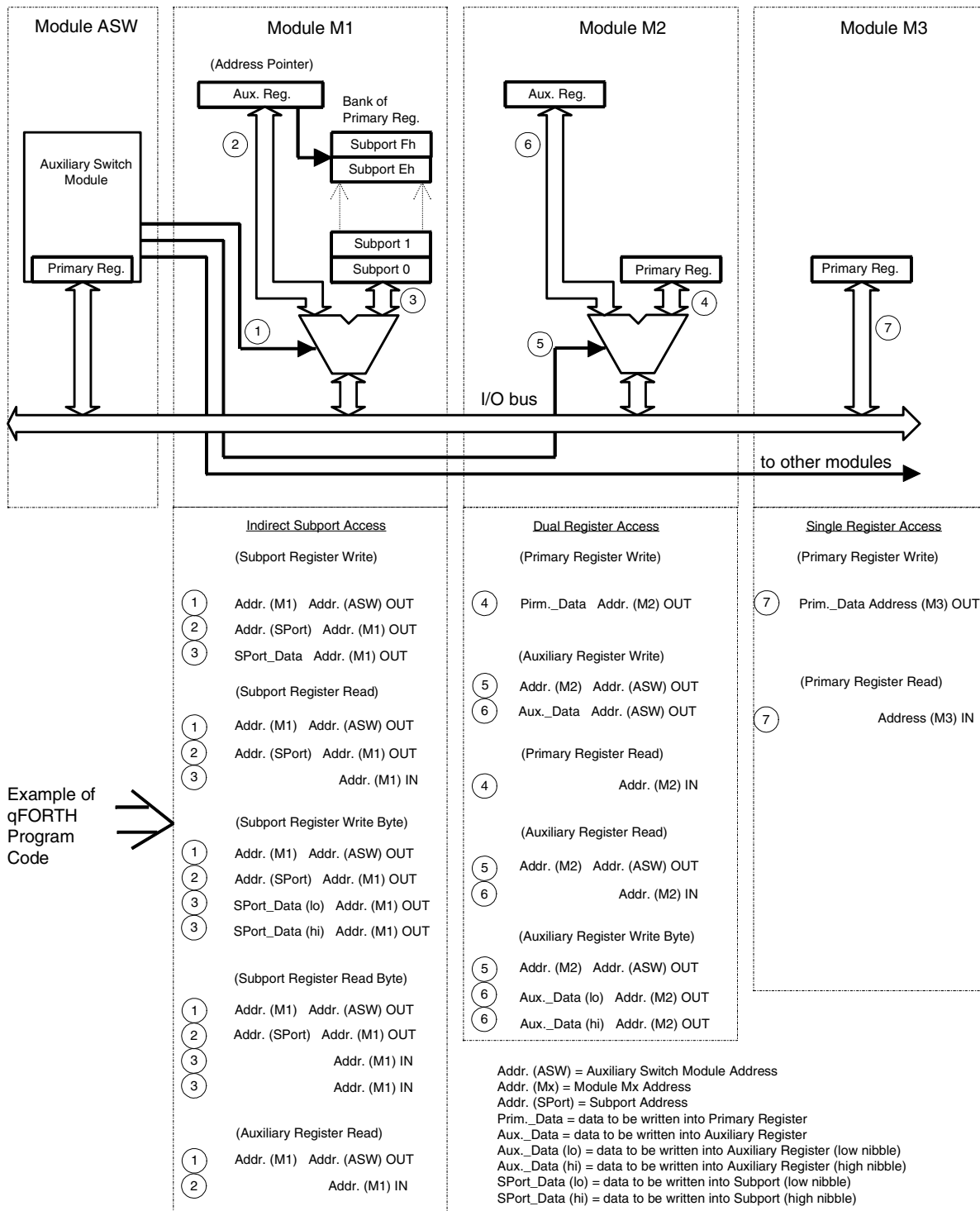

Example of qFORTH Program Code

Table 3-1. Peripheral Addresses

Port Address	Name	Write/Read	Reset Value	Register Function	Module Type	See Page	
0	P0DAT	W/R	1111b	Port 0 - data register/input data	M3	24	
1	P1DAT	W/R	1111b	Port 1- data register/input data	M3	24	
2	PAIPR	W	1111b	Port A - interrupt priority register	M2	26	
	Auxiliary PAICR	W	1111b	Port A - interrupt control register		26	
3	CWD	R	—	Watchdog timer reset	M3	34	
	PBIBR	W	1111b	Port B- interrupt priority register	M2	26	
	Auxiliary PBICR	W	1111b	Port B- interrupt control register		26	
4	P4DAT	W/R	1111b	Port 4 - data register/pin data	M2	24	
	Auxiliary P4DDR	W	1111b	Port 4 - data direction register		24	
5	P5DAT	W/R	1111b	Port 5 - data register/pin data	M2	24	
	Auxiliary P5DDR	W	1111b	Port 5 - data direction register		24	
6	P6DAT	W/R	0011b	Port 6 - data register/pin data	M2	29	
	Auxiliary P6CR	W	1111 1111b	Port 6 - control register (byte)		29	
7	P7DAT	W/R	1111b	Port 7- data register/pin data	M2	24	
	Auxiliary P7DDR	W	1111b	Port 7- data direction register		24	
8	ASW	W	1111b	Auxiliary switch register	ASW	20	
9	TCM	W/R	1111b	Data to/from subport addressed by TCSUB	M1	20	
	Auxiliary	T0SR	R	0000b	Timer 0 interrupt status register	M1	41
		TCSUB	W	1111b	Timer/counter subport address	M1	35
	Subport address						
	0	T0MO	W	1111b	Timer 0 mode register	M1	40
	1	T0CR	W	1111b	Timer 0 control register	M1	42
	2	T1M0	W	1111b	Timer 1 mode register	M1	49
	3	T1CR	W	1111b	Timer 1 control register	M1	50
	4	TCMO	W	1111b	Timer/counter mode register	M1	39
	5	TCIOR	W	1111b	Timer/counter I/O control register	M1	37
	6	TCCR	W	1111b	Timer/counter control register	M1	36
	7	TCIP	W	1111b	Timer/counter interrupt priority	M1	37
	8	T1CP	W	xxxx xxxxb	Timer 1 compare register (byte)	M1	51
		T1CA	R	xxxx xxxxb	Timer 1 capture register (byte)	M1	51
	9	T0CP	W	xxxx xxxxb	Timer 0 compare register (byte)	M1	43
		T0CA	R	xxxx xxxxb	Timer 0 capture register (byte)	M1	43
	A	BZCR	W	1111b	Buzzer control register	M1	54
	B-F			—	Reserved		
	A	PADAT	W/R	1111b	Port A - data register/pin data	M2	24
		Auxiliary PADDR	W	1111b	Port A - data direction register		24
B	PBDAT	W/R	1111b	Port B - data register/pin data	M2	24	
	Auxiliary PBDDR	W	1111b	Port B - data direction register		24	
C	PCDAT	W/R	1111b	Port C - data register/pin data	M2	24	
	Auxiliary PCDDR	W	1111b	Port C - data direction register		24	
D	RBR	W	0000b	Rom bank switch register	M3	8	
E	SC	W	1111b	System configuration register	M2	18	
	Auxiliary CM	W/R	1111b	Clock management register		18	
F	ITFSR	W	1111b	Interval timer frequency select register	M2	33	
	Auxiliary ITFSR	W	1111b	Interval timer interrupt priority register		32	

3.2 Bi-directional Ports

Table 3-2. Overview of Port Features

Port Address	0	1	4	5	6	7	A	B	C
Number of bits	4	4	4	4	2	4	4	4	4
Bit wise programmable direction	no	no	yes	yes	yes	yes	yes	yes	yes
Output drivers mask configurable ⁽¹⁾	no ⁽²⁾	yes	yes	yes	yes	yes	yes	yes	yes
Dynamic pull-up/-down typ. (Ω) ⁽³⁾	500k	500k	500k	500k	500k	500k	500k	500k	500k
Static pull-up/-down typ. (Ω) ⁽⁴⁾	none	none	30k	30k	4k	30k	30k	30k	30k
Schmitt trigger inputs	yes	yes	yes	no	yes	no	yes	yes	no
Additional functions			Timer 0		External interrupt		Port monitor/ coded reset	Port monitor	

- Notes:
1. Either “open drain down”, “open drain up” or CMOS output configuration
 2. This output must always be CMOS
 3. The Dynamic pull-up/-down transistors are mask programmable and if programmed, are only activated when the associated complementary driver transistor is off. i.e., A dynamic pull-up transistor is only active when the port is either in input mode (both drivers off) or when a logical 1 is written to the port pad (low driver off) in output mode (Figure 3-3 on page 25)
 4. The static pull-up/-down transistors are mask programmed and if programmed are always active independent of the port direction or driven state (Figure 3-3 on page 25)

For further data see section “DC Operating Characteristics”.

All Ports (0, 1, 4, 5, 7, A, B and C with the exception of Port 6) are 4 bits wide. Port 6 has a data width of only 2 bits (bit 0 and bit 1). The ports may be used for data input or output. All ports that can either directly or indirectly generate an interrupt are equipped with Schmitt trigger inputs. A variety of mask options are available such as open drain, open source and full complementary outputs as well as different types of pull-up and pull-down transistors. All Port Data Registers (PxDAT) are I/O mapped to the primary address register of the respective port address, and the Port Data Direction Register (PxDDR) to the corresponding auxiliary register.

All bi-directional ports except Port 0 and Port 1, include a bit wise- programmable Data Direction Register (PxDDR) which allows the individual programming of each port bit as input or output. It is also possible to read the pin condition when in output mode. This is a useful feature for self-testing and for collision detection on wired-OR bus systems.

There are five different types of bi-directional ports:

- Ports 0 and 1: 4-bit wide, bi-directional ports with automatic full bus width direction switching
- Port 4: 4-bit wide, bit wise programmable bi-directional port also provides the I/O interface to Timer 0 and the Buzzer
- Ports 5, 7 and C: 4-bit wide, bit wise programmable high drive I/O ports
- Port 6: 2-bit wide, bit wise programmable bi-directional port with optional static (4 k Ω) pull-up/-down and programmable interrupt logic
- Ports A and B: 4-bit wide, bit wise programmable bi-directional ports with optional port monitor function

3.2.1 Port Data Register (PxDAT)

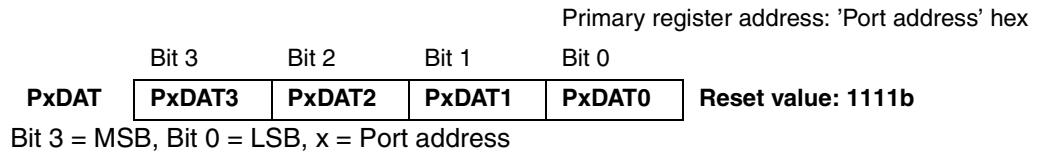

3.2.2 Port Data Direction Register (PxDDR)

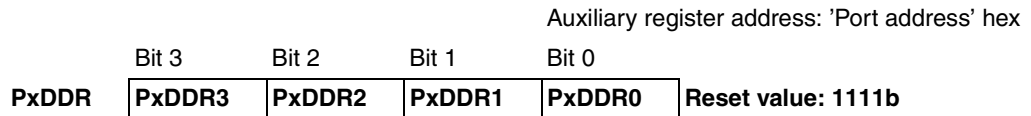

Table 3-3. Port Data Direction Register (PxDDR)

Code: 3 2 1 0	Function
x x x 1	BPx0 in input mode
x x x 0	BPx0 in output mode
x x 1 x	BPx1 in input mode
x x 0 x	BPx1 in output mode
x 1 x x	BPx2 in input mode
x 0 x x	BPx2 in output mode
1 x x x	BPx3 in input mode
0 x x x	BPx3 in output mode

3.2.3 Bi-directional Port 0 and Port 1

In this port type, the data direction register is not independently software programmable because the direction of the complete port is switched automatically when an I/O instruction occurs (see Figure 3-2 on page 25). The port can be switched to output mode with an OUT instruction and to input with an IN instruction. The data written to a port will be stored in the output data latches and appears immediately at the port pin following the OUT instruction. After RESET, all output latches are set to 1 and the ports are switched to input mode. An IN instruction reads the condition of the associated pins.

Note: Care must be taken when switching these bi-directional ports from output to input. The capacitive pin loading at this port, in conjunction with the high resistance pull-ups, may cause the CPU to read the contents of the output data register rather than the external input state. This can be avoided by using either of the following programming techniques:

Use two IN instructions and DROP the first data nibble. The first IN switches the port from output to input and the DROP removes the first invalid nibble. The second IN reads the valid pin state.

Use an OUT instruction followed by an IN instruction. With the OUT instruction, the capacitive load is charged or discharged depending on the optional pull-up /pull-down configuration. Write a 1 for pins with pull-up resistors, and a 0 for pins with pull-down resistors.

Figure 3-2. Bi-directional Port 0 and 1

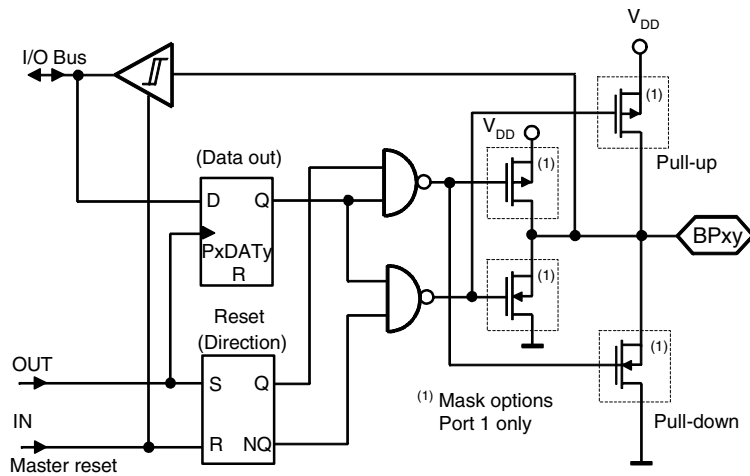

3.2.4 Bi-directional Port 5, Port 7 and Port C

All bi-directional ports except Port 0 and Port 1, include a bitwise programmable Data Direction Register (PxDDR) which allows the individual programming of each port bit as input or output. It also enables the reading of the pin condition in output mode.

The bi-directional Ports 5, 7 and C as well as Port A and Port B are equipped with the same standard I/O logic. However, Port 5, Port 7 and Port C include standard CMOS input stages, whereas Port A, Port B and all other digital signal pins have Schmitt trigger inputs. Port 5 and Port 7 have high current output drive capability for up to 20 mA at 5 V. Whereby the instantaneous sum of the output currents should not exceed 100 mA.

Figure 3-3. Bi-directional Ports 5, 7, A, B and C

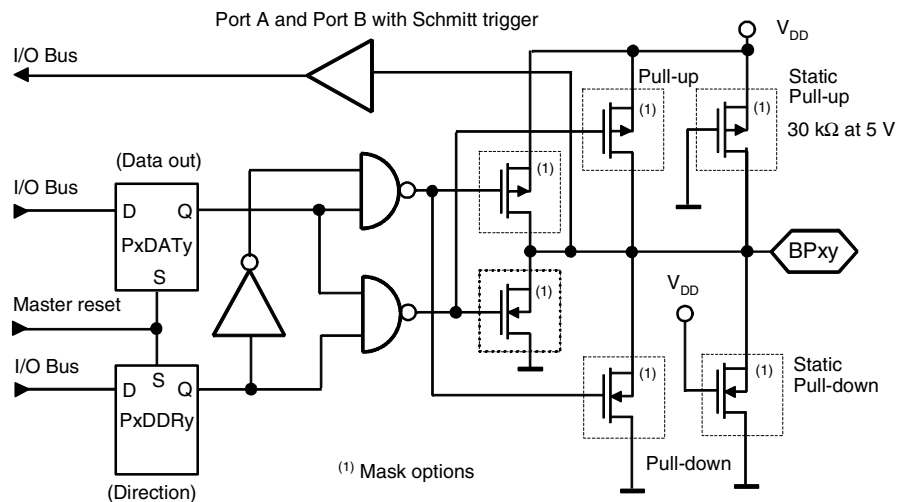

3.2.5 Bi-directional Port A and Port B with Port Monitor Function

Figure 3-4. Port Monitor Module of Port A and Port B

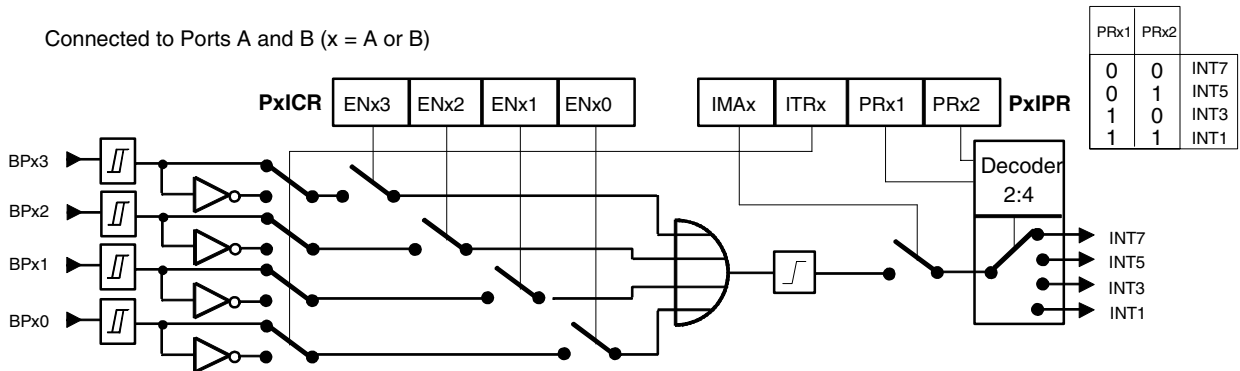

In addition to the standard I/O functions described in section “Bi-directional Port 5, Port 7 and Port C”, both Port A (BPA3 - BPA0) and Port B (BPB3 - BPB0) are equipped with Schmitt trigger inputs and a port monitor module. This module is connected across all four port pins (see Figure 3-4) and is intended for monitoring those pins selected by control bits Enx3 - Enx0 and generating an interrupt when the first pin leaves a preselected logical default idle state. This state is defined by control bit ITRx. Transitions on other pins will only cause an interrupt if the other pins have first returned to the idle state. This, for example is useful for interrupt initiated port scanning without the power consuming task of continuously polling for port activity.

Using the Port Interrupt Control Register (PxICR), pins can be individually selected. A non-selected pin cannot generate an interrupt. The Port Interrupt Priority Register (PxIPR) allows masking of each interrupt, definition of the interrupt edge and programming of the interrupt priority levels. When programming or reprogramming either of the port monitor control registers, any previously generated interrupt on that port which has not yet been acknowledged by the CPU or an interrupt generated by the reprogramming itself is automatically cleared. Port A can also be used for a mask programmable coded reset. For more information see section “Hardware Reset”.

The Port Interrupt Priority Registers PAIPR and PBIPR are I/O mapped to the primary address registers of the Port Monitor Module addresses '2'h and '3'h respectively. The Port Interrupt Control Registers PAICR and PBICR are mapped to the corresponding auxiliary registers.

3.2.5.1 Port Monitor Interrupt Priority Register (PxIPR)

x = 'A' (Port A) or 'B' (Port B)

(Port A) Primary register address: '2'h

(Port B) Primary register address: '3'h

	Bit 3	Bit 2	Bit 1	Bit 0
PxIPR	IMx	ITRx	PRx2	PRx1

Reset value: 1111b

- IMx - Interrupt Mask
- ITRx - Interrupt Transition
- PRx2..1 - Interrupt Priority code

Table 3-4. Port Monitor Interrupt Priority Register (PxIPR)

Code 3 2 1 0	Function
x x 0 0	Port monitor interrupt priority 7
x x 0 1	Port monitor interrupt priority 5
x x 1 0	Port monitor interrupt priority 3
x x 1 1	Port monitor interrupt priority 1
x 0 x x	Port monitor interrupt on falling edge
x 1 x x	Port monitor interrupt on rising edge
0 x x x	Port monitor interrupt enabled
1 x x x	Port monitor interrupt disabled

3.2.5.2 Port Monitor Interrupt Control Register (PxICR)

x = 'A' (Port A) or 'B' (Port B)

(Port A) Primary register address: '2'hex

(Port B) Primary register address: '3'hex

	Bit 3	Bit 2	Bit 1	Bit 0	
PxICR	ENx3	ENx2	ENx1	ENx0	Reset value: 1111b

ENx3... 0 port monitor input ENable code

Table 3-5. Port Monitor Interrupt Control Register (PxICR)

Code 3 2 1 0	Function
x x x 0	Bit 0 can generate an interrupt
x x x 1	Bit 0 cannot generate an interrupt
x x 0 x	Bit 1 can generate an interrupt
x x 1 x	Bit 1 cannot generate an interrupt
x 0 x x	Bit 2 can generate an interrupt
x 1 x x	Bit 2 cannot generate an interrupt
0 x x x	Bit 3 can generate an interrupt
1 x x x	Bit 3 cannot generate an interrupt

3.2.6 Bi-directional Port 6

Figure 3-5. Bi-directional Port 6

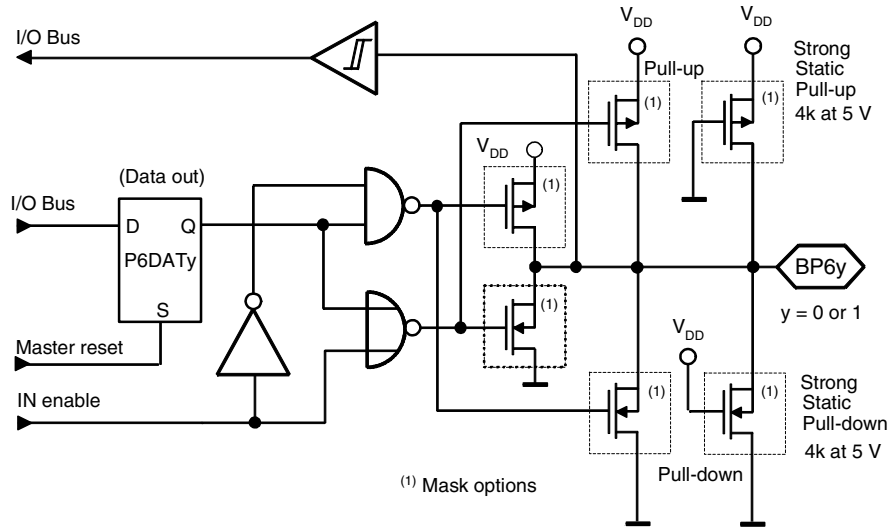

This 2-bit bi-directional port can be used as a bitwise programmable I/O. The data is LSB aligned so that the two MSB's will not appear on the port pins when written. The port pins can also be used as external interrupt inputs (see Figure 3-5 and Figure 3-6 on page 30). Both interrupts can be masked or independently configured to trigger on either edge. The interrupt priority levels are also configurable. The interrupt configuration and port direction is controlled by the Port 6 Control Register (P6CR). An additional low resistance pull-up transistor (mask option) provides an internal bus pull-up for serial bus applications.

In output mode (PxDDR bit = 0), the respective Port Data Register (PxDAT) bit appears on the port pin, driven by an output port driver stage which can be mask programmed as open drain, or full complementary CMOS. With an IN instruction the actual pin state can be read back into the controller at any time without changing the port directional mode. If the output port is mask configured as an open drain driver, the controller is able to receive the external data on this pin without switching into input mode as long as the output transistor is switched off.

In input mode (PxDDR bit = 1), the output driver stage is deactivated, so that an IN instruction will directly read the pin state which can be driven from an external source. In this case, the state of the Port Data Register (PxDAT), although not appearing at the pin itself, remains unchanged. High resistance mask selectable pull-up or pull-down transistors are automatically switched onto the port pin in input mode. The Port Data Register is written to the respective port address with an OUT instruction.

The Port 6 Data Register (P6DAT) is I/O mapped to the primary address register of address '6'hex and the Port 6 Control Register (P6CR) to the corresponding auxiliary register. The P6CR is a byte wide register and is written by writing the low nibble first and then the high nibble (see Section 3.1 on page 20).

3.2.6.1 Port 6 Data Register (P6DAT)

				Primary register address: '6'hex	
	Bit 3	Bit 2	Bit 1	Bit 0	
P6DAT	Not used	Not used	P6DAT1	P6DAT0	Reset value: xx11b

The unused bits 2 and 3 are 0, if read.

3.2.6.2 Port 6 Control Register (P6CR)

				Auxiliary register address: '6'hex	
	Bit 3	Bit 2	Bit 1	Bit 0	
P6CR	First write cycle	P61IM2	P61IM1	P60IM2	P60IM1
	Second write cycle	P61PR2	P61PR1	P60PR2	P60PR1
	Bit 7	Bit 6	Bit 5	Bit 4	
					Reset value: 1111b

P6xIM2, P6xIM1 - Port 6x interrupt mode/direction code

P6xPR2, P6xPR1 - BP6x interrupt priority code

Table 3-6. Port 6 Control Register (P6CR)

Auxiliary Address: '6'hex			
First Write Cycle		Second Write Cycle	
Code 3 2 1 0	Function	Code 3 2 1 0	Function
x x 1 1	BP60 in input mode - interrupt disabled	x x 1 1	BP60 set to priority 1
x x 0 1	BP60 in input mode - rising edge interrupt	x x 1 0	BP60 set to priority 3
x x 1 0	BP60 in input mode - falling edge interrupt	x x 0 1	BP60 set to priority 5
x x 0 0	BP60 in output mode - interrupt disabled	x x 0 0	BP60 set to priority 7
1 1 x x	BP61 in input mode - interrupt disabled	1 1 x x	BP61 set to priority 0
0 1 x x	BP61 in input mode - rising edge interrupt	1 0 x x	BP61 set to priority 2
1 0 x x	BP61 in input mode - falling edge interrupt	0 1 x x	BP61 set to priority 4
0 0 x x	BP61 in output mode - interrupt disabled	0 0 x x	BP61 set to priority 6

Figure 3-6. Port 6 External Interrupts

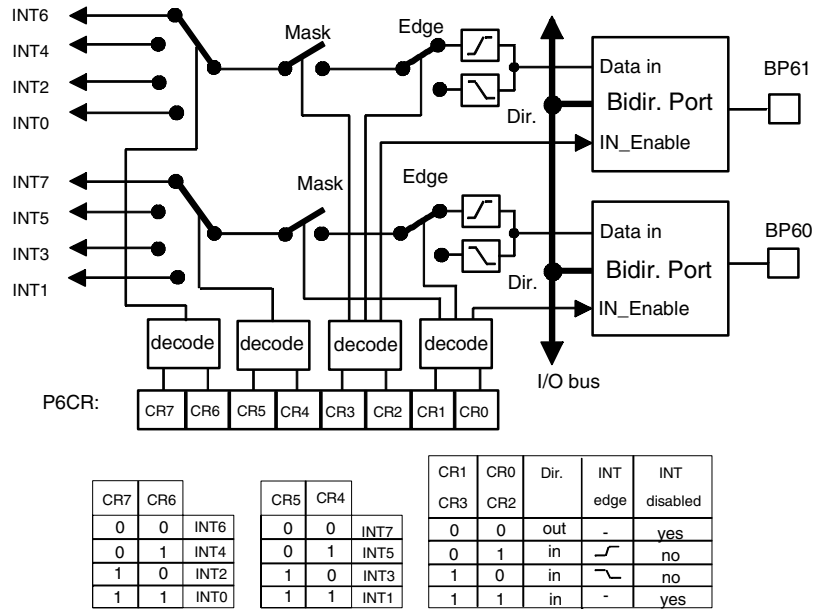

3.2.7 Bi-directional Port 4

The bi-directional Port 4 is both a bit wise configurable I/O port and provides the external pins for both the Timer 0 and the internal buzzer generator. As an I/O port, it performs in exactly the same way as bi-directional Port 5, 7, A, B and C (see Figure 3-3 on page 25). Two additional multiplexers allow data and port direction control to be passed over to other internal modules (Timer 0 or Buzzer). Each of the four Port 4 pins can be individually switched by the Timer/Counter I/O Register (TCIO). Figure 3-7 shows the internal interfaces to Port 4.

Figure 3-7. Bi-directional Port 4

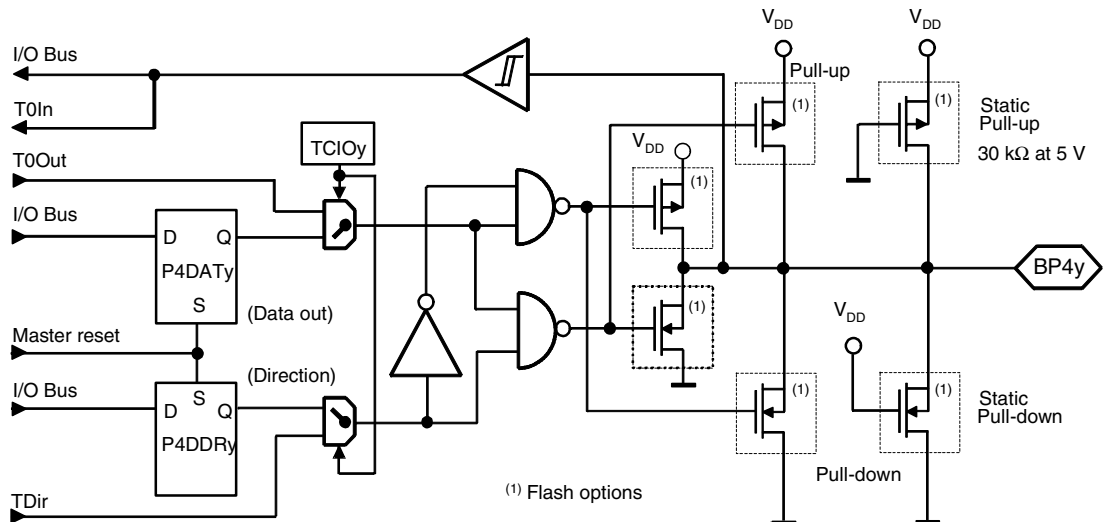

3.2.8 TIM1 - Dedicated Timer 1 I/O Pin

Figure 3-8. Bi-directional Pin TIM1

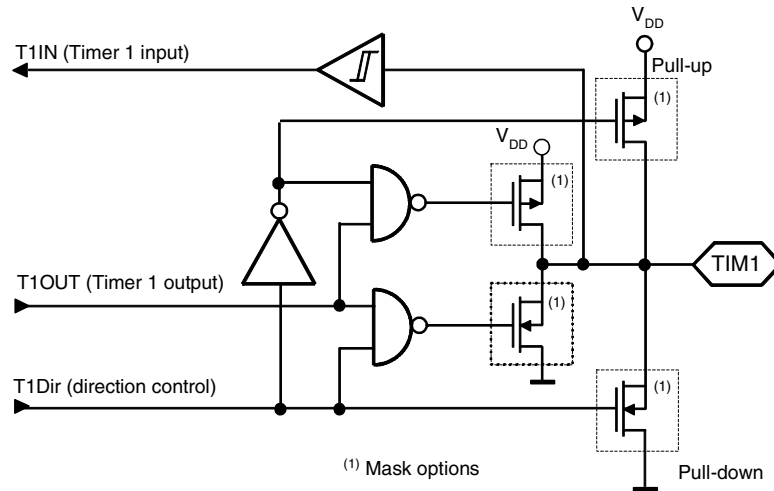

TIM1 is a dedicated bi-directional I/O stage for signal communication to and from Timer 1 in the timer/counter module (see Figure 3-8). It has no I/O bus interface and is not directly accessible from the CPU. Direction control is performed from the timer/counter configuration registers.

3.3 Interval Timers/Prescaler

The interval timers are based on a frequency divider for generating two independent time base interrupts. It is driven by SUBCL generated by the clock module (see Figure 2-8 on page 15) and consists of a 15-stage binary divider and two programmable multiplexers for selecting the appropriate interrupt frequencies for each interrupt source (see Figure 3-9 on page 32). Each multiplexer is completely independent and is controlled by the common Interval Timer Frequency Select Register (ITFSR). Buffer registers store the respective frequency select codes and ensure complete programming independence of each interrupt channel.

Interrupt masking and programming of the interrupt priority levels is performed with the aid of the Interval Timer Interrupt Priority Register (ITIPR).

Figure 3-9. Interval Timers/Prescaler

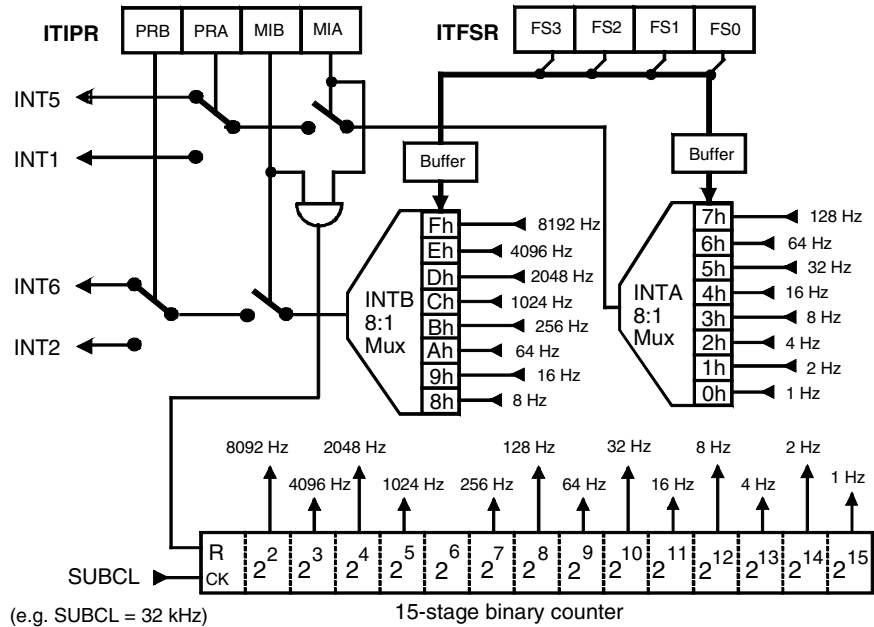

3.3.1 Interval Timer Registers

The Interval Timer Frequency Select Register (ITFSR) is I/O mapped to the primary address register of the prescaler/interval timer address ('F'hex) and the Interval Timer Interrupt Priority Register (ITIPR) to the corresponding auxiliary register. The interrupt masks MIA and MIB enable interrupt masking of INTA and INTB respectively. Each interrupt source can be programmed with PRA and PRB to one of two interrupt priority levels. Disabling both interrupts resets the interval timer.

3.3.1.1 Interval Timer Interrupt Priority Register (ITIPR)

Auxiliary register address (write only): 'F'hex

	Bit 3	Bit 2	Bit 1	Bit 0
ITIPR	PRB	PRA	MIB	MIA

Reset value: 1111b

- PRB - Priority select Interval Timer Interrupt INTB
- PRA - Priority select Interval Timer Interrupt INTA
- MIB - Mask Interval Timer Interrupt INTB
- MIA - Mask Interval Timer Interrupt INTA

Table 3-7. Interval Timer Interrupt Priority Register (ITIPR)

Code 3 2 1 0	Function
x x 1 1	Reset prescaler and halt
x x x 1	Interrupt A disabled
x x x 0	Interrupt A enabled
x x 1 x	Interrupt B disabled
x x 0 x	Interrupt B enabled
x 1 x x	Interrupt A => priority 1
x 0 x x	Interrupt A => priority 5
1 x x x	Interrupt B => priority 2
0 x x x	Interrupt B => priority 6

3.3.1.2 Interval Timer Frequency Select Register

Primary register address (write only): 'F'hex

	Bit 3	Bit 2	Bit 1	Bit 0	
ITFSR	FS3	FS2	FS1	FS0	Reset value: 1111b

FS3 ... 0 - Frequency select code

Table 3-8. Interval Timer Frequency Select Register (ITFSR)

Code 3 2 1 0	Function	SUBCL divide by	SUBCL = 32 kHz
0 0 0 0	INTA	2^{15}	Select 1 Hz
0 0 0 1		2^{14}	Select 2 Hz
0 0 1 0		2^{13}	Select 4 Hz
0 0 1 1		2^{12}	Select 8 Hz
0 1 0 0		2^{11}	Select 16 Hz
0 1 0 1		2^{10}	Select 32 Hz
0 1 1 0		2^9	Select 64 Hz
0 1 1 1		2^8	Select 128 Hz
1 0 0 0	INTB	2^{12}	Select 8 Hz
1 0 0 1		2^{11}	Select 16 Hz
1 0 1 0		2^9	Select 64 Hz
1 0 1 1		2^7	Select 256 Hz
1 1 0 0		2^5	Select 1024 Hz
1 1 0 1		2^4	Select 2048 Hz
1 1 1 0		2^3	Select 4096 Hz
1 1 1 1		2^2	Select 8192 Hz

The control bit FS3 determines whether the INTA or the INTB buffer register is loaded with the select code (FS2-FS0). This allows independent programming of interval times for INTA and INTB.

3.4 Watchdog Timer

Figure 3-10. Watchdog Timer

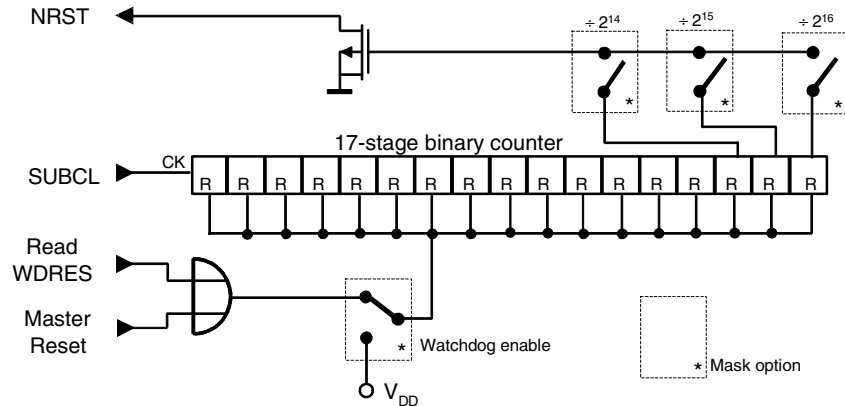

The watchdog timer is a 17-stage binary divider clocked by SUBCL generated within the clock module (see Figure 2-8 on page 15 and Figure 3-10). It can only be enabled as a mask option whereby it must be periodically reset from the application program. The program cannot disable the watchdog. If the CPU find itself for an extended length of time in SLEEP mode or in a section of program that includes no watchdog reset, then the watchdog will overflow, thus forcing the NRST pin low. This initiates a master reset. The timeout period can be set to 0.5, 1 or 2 seconds (if SUBCL = 32 kHz) by using a mask option.

To reset the watchdog, the program must perform an IN-instruction on the address CWD ('3'hex). No relevant data is usually received. The operation is therefore normally followed by a DROP to flush the data from the stack.

3.5 Timer/Counter Module (TCM)

The TCM consists of two timer/counter blocks (Timer 0 and Timer 1) which can be used separately, or together as a single 16-bit counter/timer (see Figure 3-11 on page 35 and Figure 3-13 on page 39). Each timer can be supplied by various internal or external clock sources. These can be selected and divided under program control using the Timer/Counter Control Register (TCCR), the Timer 0 Control Register (T0CR) and the Timer 1 Control Register (T1CR). Capture and compare registers (T0CA, T1CA, T0CP and T1CP) not only allow event counting, but also the generation of various timed output waveforms including programmable frequencies, modulated melody tones, Pulse Width Modulated (PWM) and Pulse Density Modulated (PDM) output signals. When in one of these signal generation modes, the capture register acts as timer shadow register, the current timer state is frozen whenever read by the CPU. Timer 0 is further equipped to perform a variety of time measurement operations. In this mode the capture register is used together with the gating logic for performing asynchronous, externally triggered snapshot measurements. These measurements include single input pulse width and period measurements and also dual input phase and positional measurements. The mode configuration is set in the Timer 0 and Timer 1 Mode Registers (T0MO and T1MO).

Each timer represents a single maskable interrupt source (T0INT and T1INT), the priority of which can be configured under program control. A Timer 0 interrupt can be caused by any of three conditions (overflow, compare or end-of-measurement). The associated status register (T0SR) differentiates between these. A status register is not necessary in Timer 1 as an interrupt is caused only on a compare condition.

Figure 3-11. Timer/Counter Module

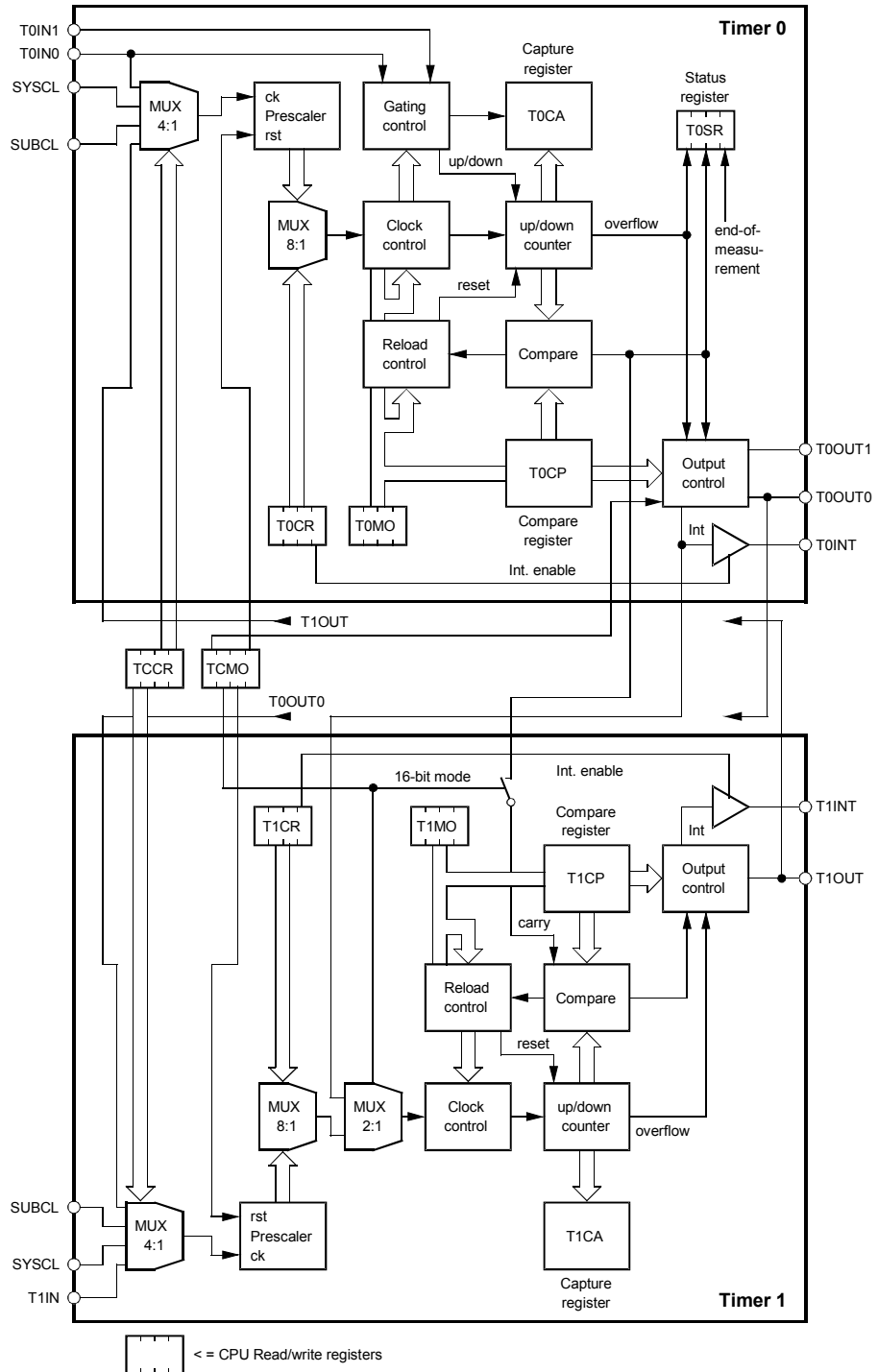

3.5.1 General Timer/Counter Control Registers

With the exception of the Timer 0 Interrupt Status Register (T0SR), all the timer/counter registers are indirectly addressed using extended addressing as described in the Section 3.1 on page 20. An overview of all register and subport addresses is shown in Table 3-1 on page 22. The Timer/Counter auxiliary register (TCSUB) holds the subport address of the particular register about to be accessed.

Care has to be taken to ensure that this subport access sequence is not interrupted. Please refer to the 'HARDC510.SCR' hardware interface file as a programming guideline.

3.5.1.1 Timer/Counter Clock Control Register (TCCR)

Subport address (indirect write access): '6'hex of Port address '9'hex

	Bit 3	Bit 2	Bit 1	Bit 0	
TCCR	T1CL2	T1CL1	T0CL2	T0CL1	Reset value: 1111b

T0CL2, T0CL1 - Timer 0 Clock source select
 T1CL2, T1CL1 - Timer 1 Clock source select

Table 3-9. Timer/Counter Clock Control Register (TCCR)

Code 3 2 1 0	Function	Direction (TDir)	
		BP40 ⁽¹⁾	TIM1
x x 0 0	Timer 0 clock = SUBCL	out	x
x x 0 1	Timer 0 clock = SYSCL	out	x
x x 1 0	Timer 0 clock = Timer1 output (T1OUT connected internally)	out	x
x x 1 1	Timer 0 clock = T0IN0 (BP40 ⁽¹⁾)	in	x
0 0 x x	Timer 1 clock = SUBCL	x	out
0 1 x x	Timer 1 clock = SYSCL	x	out
1 0 x x	Timer 1 clock = Timer 0 output (T0OUT0 connected internally)	x	out
1 1 x x	Timer 1 clock = TIM1	x	in

Note: 1. If TCIO0 = low (connects Timer 0 to Port 4)

The Timer/Counter Clock Control Register (TCCR) controls the clock source to both Timer 0 and Timer 1 prescalers. If an external clock source (on BP40 or TIM1) is selected, then the corresponding port direction is automatically switched to input mode (see Figure 3-11 on page 35).

Note: The TCIO0 bit must be set low for the BP40 external timer/counter access.

3.5.1.2 Timer/Counter Interrupt Priority Register (TCIP)

The Timer/Counter Interrupt Priority register (TCIP) is used to configure Timer 0 and Timer 1 interrupt priority levels.

Subport address (indirect write access): '7'hex of Port address '9'hex

	Bit 3	Bit 2	Bit 1	Bit 0	
TCIP	T1IP2	T1IP1	T0IP2	T0IP1	Reset value: 1111b

T0IP2, T0IP1 - Timer 0 Interrupt Priority code
 T1IP2, T1IP1 - Timer 1 Interrupt Priority code

Table 3-10. Timer/Counter Interrupt Priority Register (TCIP)

Code 3 2 1 0	Function
x x 1 1	Timer 0 interrupt priority 1
x x 1 0	Timer 0 interrupt priority 3
x x 0 1	Timer 0 interrupt priority 5
x x 0 0	Timer 0 interrupt priority 7
1 1 x x	Timer 1 interrupt priority 0
1 0 x x	Timer 1 interrupt priority 2
0 1 x x	Timer 1 interrupt priority 4
0 0 x x	Timer 1 interrupt priority 6

3.5.1.3 Timer/Counter I/O Control Register (TCIOR)

Subport address (indirect write access): '5'hex of Port address '9'hex

	Bit 3	Bit 2	Bit 1	Bit 0	
TCIOR	TCIO3	TCIO2	TCIO1	TCIO0	Reset value: 1111b

TCIO3...0 - Timer/Counter I/O mode select

Table 3-11. Timer/Counter I/O Control Register (TCIOR)

Code 3 2 1 0	Function
x x x 1	BP40 - standard port mode
x x x 0	BP40 - Timer 0 clock input (T0IN0) or Timer 0 output (T0OUT0)
x x 1 x	BP41 - standard port mode
x x 0 x	BP41 - Timer 0 gate input (T0IN1) or Timer 0 output (T0OUT1)
x 1 x x	BP42 - standard port mode
x 0 x x	BP42 - Buzzer output (BUZ)
1 x x x	BP43 - standard port mode
0 x x x	BP43 - Buzzer output (NBUZ)

By using the Timer/Counter I/O Control Register (TCIOR) the program can configure the respective Port 4 pins as either standard data I/O ports or as external signal ports for the Timer 0 and Buzzer. The Timer 1 uses a dedicated I/O pin TIM1, whose direction is controlled solely by the TCCR (see Figure 3-8 on page 31). It should be noted that if a TCIOR bit is set low, then the corresponding port data direction register (P4DDR) bit no longer influences the port direction. In the case of BP40 and BP41, the port direction is then controlled entirely by the timer/counter configuration registers (TCCR,T0MO), while pins BP42 and BP43 become uni-directional buzzer outputs.

Figure 3-12. Timer/Counter and Buzzer External Interface

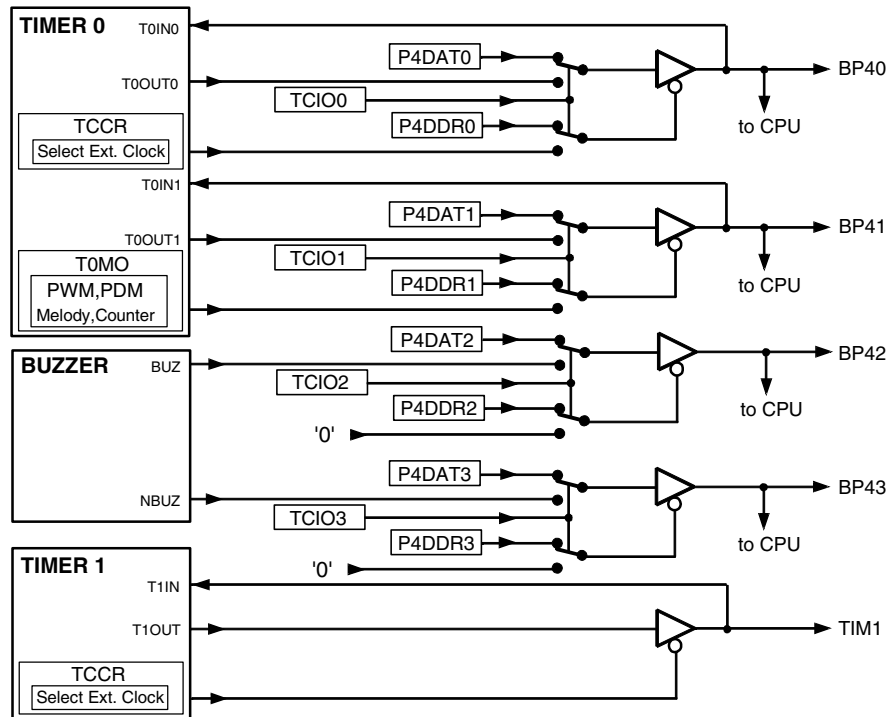

3.5.1.4 Timer/Counter Mode Register (TCMO)

Subport address (indirect write access): '4'hex of Port address '9'hex

	Bit 3	Bit 2	Bit 1	Bit 0	
TCMO	T0NINV	TC8	T1RST	T0RST	Reset value: 1111b
T0NINV	Timer 0 output (BP41) appears non-inverted at BP40				
TC8	Timer/Counter in 8-/16-bit mode				
T1STP	Timer 1 Stop/Run				
T0STP	Timer 0 Stop/Run				

Table 3-12. Timer/Counter Mode Register (TCMO)

Code 3 2 1 0	Function
x x x 0	Timer 0 running
x x x 1	Timer 0 halted
x x 0 x	Timer 1 running
x x 1 x	Timer 1 halted
x 0 x x	Timer/counter in 16-bit mode
x 1 x x	Timer/counter in 8-bit mode
0 x x x	Inverted output BP41 appears on BP40 (BP40 = NOT BP41)
1 x x x	Non-inverted output BP41 appears on BP40 (BP40 = BP41)

3.5.2 Timer/Counter in 16-bit Mode

Figure 3-13. 16-bit Mode

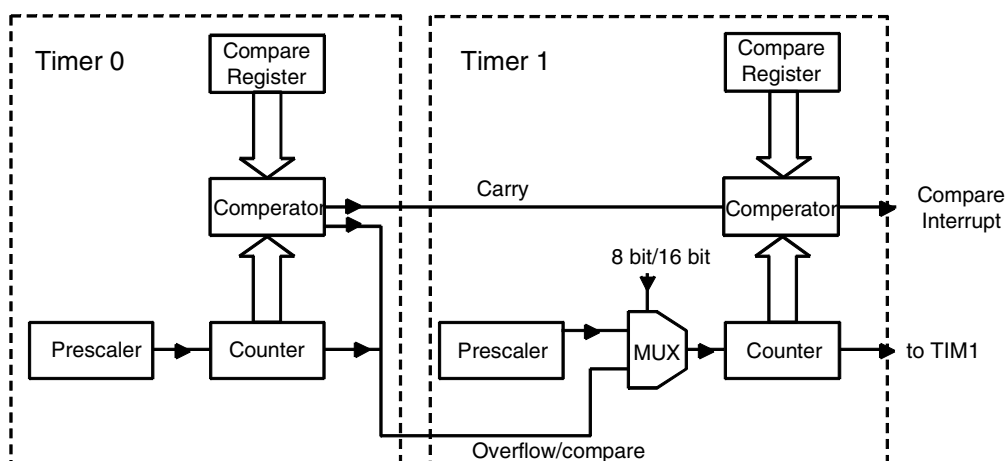

In 16-bit mode, Timer 0 and Timer 1 are cascaded thus forming a 16-bit counter (see Figure 3-13) whereby, irrespective of the state of Timer 0 interrupt mask bit (TOIM), the Timer 1 counts both Timer 0 overflow and compares interrupt events. These are generated according to the state of the Timer 0 Mode Register as described in the T0MO table. The comparators are also cascaded so that when both Timer 0 and Timer 1 match their respective compare registers, Timer 1 generates both an output signal and a compare interrupt (if unmasked).

In measurement modes, only Timer 0 capture register is loaded with Timer 0's contents on an end-of-measurement event. Timer 1 capture register operates solely as a shadow register. There is no 16-bit capture operation, so the user program must check if Timer 1 has incremented between reading the lower and higher byte. Likewise, there is no automatic suppression of spurious interrupts which could conceivably be generated between writing to Timer 0 and Timer 1 compare registers.

3.5.3 Timer 0 Modes

The Timer 0 mode configuration is defined in the Timer 0 Mode Register (T0MO). The available modes and the effect on the Timer 0 interrupt and interrupt flags is shown below. In all modes except the position measurement mode, Timer 0 acts as an up-counter, the related clock frequency being defined by the selected clock source and the prescaler division factor. The counter can be reset and halted at any time by the T0RST bit of the TCMO register which also resets all the interrupt status flags and capture registers. Whenever Port 4 BP40 and BP41 pins are required for Timer 0 I/O, then the appropriate TCIOR enable bit must be set low. In this case, the port direction switching is handled automatically by the hardware. In modes where the BP40 is not used as a timer clock input or as a melody envelope output, the BP40 outputs the same signal as that appearing on BP41. With the help of the T0NINV bit of the Timer/Counter Mode Register (TCMO), the BP41 output can be inverted so that BP40 and BP41 form a differential output stage which can be used for directly driving piezo buzzers or small stepper motors.

3.5.3.1 Timer 0 Mode Register (T0MO)

Subport address (indirect write access): '0'hex of Port address '9'hex

	Bit 3	Bit 2	Bit 1	Bit 0	
T0MO	T0MO3	T0MO2	T0MO1	T0MO0	Reset value: 1111b

T0MO3 ... 0 - Timer 0 Mode Code

Table 3-13. Timer 0 Mode Register (TOMO)

Code 3210	Function	Assuming TCIOR1 = TCIOR0 = Low		Interrupt Set/ T0SR Affected		
		BP40 ⁽³⁾	BP41	cmp	ofl	eom
0 0 0 0	Reserved			-	-	-
0 0 0 1	Reserved			-	-	-
0 0 1 0	Modulated melody mode	Envelope (out)	Tone (out)	y/y	y/y	n/n
0 0 1 1	Melody mode	Tone (out)	Tone (out)	y/y	y/y	n/n
0 1 0 0	Counter-auto reload (50% duty cycle)	Toggle (out)/Clock (in)	Toggle (out)	y/y	y/y	n/n
0 1 0 1	Counter-free running (50% duty cycle)	Toggle (out)/Clock (in)	Toggle (out)	n/y	y/y	n/n
0 1 1 0	Pulse density modulation	PDM (out)/Clock (in)	PDM (out)	n/y	y/y	n/n
0 1 1 1	Pulse width modulation	PWM (out)/Clock (in)	PWM (out)	n/y	y/y	n/n
1 0 0 0	Phase measurement	Signal 1 (in)	Signal 2 (in)	n/n	y/y	y/y
1 0 0 1	Position measurement	Signal 1 (in)	Signal 2 (in)	(1)	(2)	n/n
1 0 1 0	Low pulse width measurement	Clock (in)	Signal (in)	n/y	y/y	y/y
1 0 1 1	High pulse width measurement	Clock (in)	Signal (in)	n/y	y/y	y/y
1 1 0 0	Counter-auto reload (strobe)	Strobe (out)/Clock (in)	Strobe (out)	y/y	y/y	n/y
1 1 0 1	Counter-free running (strobe)	Strobe (out)/Clock (in)	Strobe (out)	n/y	y/y	n/y
1 1 1 0	Period measurement (rising edge)	Clock (in)	Signal (in)	n/y	y/y	y/y
1 1 1 1	Period measurement (falling edge)	Clock (in)	Signal (in)	n/y	y/y	y/y

- Notes:
1. The compare interrupt/status flag can only be set when counting up
 2. The overflow interrupt/status flag is set on both an overflow or an underflow
 3. The BP40 signals can be inverted if T0NINV=0 (TCMO register)

3.5.3.2 Timer 0 Interrupt Status Register (T0SR)

Auxiliary register address (read access): '9'hex

	Bit 3	Bit 2	Bit 1	Bit 0	
T0SR	not used	T0EOM	T0OFL	T0CMP	Reset value: x000b

Note: The status register is reset automatically when read and also when Timer 0 is reset.

T0EOM Timer 0 End Of Measurement status flag

T0OFL Timer 0 OverFLow status flag

T0CMP Timer 0 CoMPare status flag

Table 3-14. Timer 0 Interrupt Status Register (TOSR)

Code 3 2 1 0	Function
x x x 1	Timer 0 compare has occurred (Timer 0 = T0CP)
x x 1 x	Timer 0 overflow or underflow has occurred
x 1 x x	Timer 0 measurement completed

The interrupt flags will be set whenever the associated condition occurs irrespective of whether the corresponding interrupt is triggered. Therefore, the status flags are still set if the interrupt condition occurs when the interrupt is masked. To see exactly when the flags are set, see TOMO control code (Table 3-13 on page 41).

Reading from the timer/counter auxiliary register will access the Timer 0 Interrupt Status Register (TOSR).

3.5.3.3 Timer 0 Control Register (T0CR)

The T0CR is responsible for the predivision of the selected Timer 0 input clock (see TCCR). It can be divided or used directly as a clock for the up/down counter. Bit 0 is the mask bit for Timer 0 interrupt.

Subport address (indirect write access): '1'hex of Port address '9'hex

	Bit 3	Bit 2	Bit 1	Bit 0	
T0CR	T0FS3	T0FS2	T0FS1	T0IM	Reset value: 1111b

- T0FS3 ... 1 – Timer 0 prescaler division factor code
T0IM – Timer 0 Interrupt Mask

Table 3-15. Timer 0 Control Register (T0CR)

Code 3 2 1 0	Function
x x x 1	Timer 0 interrupt disabled
x x x 0	Timer 0 interrupt enabled
0 0 0 x	Timer 0 prescaler divide by 256
0 0 1 x	Timer 0 prescaler divide by 128
0 1 0 x	Timer 0 prescaler divide by 64
0 1 1 x	Timer 0 prescaler divide by 32
1 0 0 x	Timer 0 prescaler divide by 16
1 0 1 x	Timer 0 prescaler divide by 8
1 1 0 x	Timer 0 prescaler divide by 4
1 1 1 x	Timer 0 prescaler bypassed

3.5.3.4 Timer 0 Compare Register (T0CP) - Byte Write

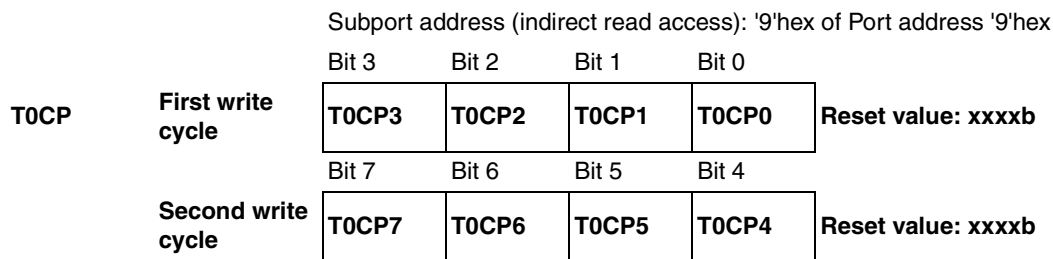

T0CP3 ... T0CP0 - Timer 0 Compare Register Data (low nibble) - first write cycle
 T0CP7 ... T0CP4 - Timer 0 Compare Register Data (high nibble) - second write cycle

The compare register T0CP is 8-bit wide and must be accessed as byte wide subport (see Section 3.1 on page 20). First the low nibble data is written and is then followed by the high nibble. Any timer interrupts are automatically suppressed until the complete compare value has been transferred.

3.5.3.5 Timer 0 Capture Register (T0CA) - Byte Read

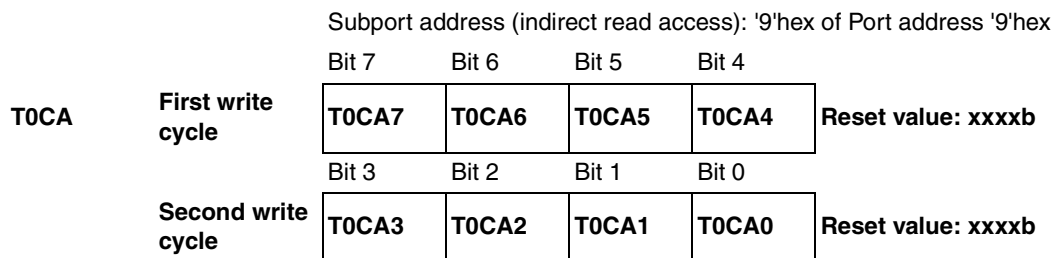

T0CA7. .. T0CA4 - Timer 0 Capture Register Data (high nibble) - first read cycle
 T0CA3 ... T0CA0 - Timer 0 Capture Register Data (low nibble) - second read cycle

Note: If the timer is read (in PDM mode only) the bit order will appear reversed, so that T0CA0 = MSB, T0CA1 = MSB - 1 T0CA6 = LSB + 1, T0CA7 = LSB.

The 8-bit capture register T0CA is read as byte wide subport. Note, however, unlike writing to the compare register, the high nibble is read first followed by the low nibble. The 8-bit timer state is captured on reading the first nibble and held until the complete byte has been read. During this transfer, the timer is free to continue counting.

3.5.3.6 Timer 0 Free Running Counter Modes (Strobe and 50% Duty Cycle)

In the free running counter mode, Timer 0 can be used as an event counter for summing external event pulses on BP40, or as a timer with an internal time-based clock. When enabled, the counter will count up generating an output signal on BP41 whenever the counter contents match the compare register (see Figure 3-14 on page 44). This signal can appear either as a strobe pulse or as a simple toggling of the output state (50% duty cycle) depending on the timer mode. Interrupts (if not masked) are generated every 256 clocks on the overflow condition. The current counter state can be read at any time by reading the capture register,. The compare register has no effect on the counter cycle time and will not influence interrupts.

Figure 3-14. Timer 0 Free Running Counter Mode

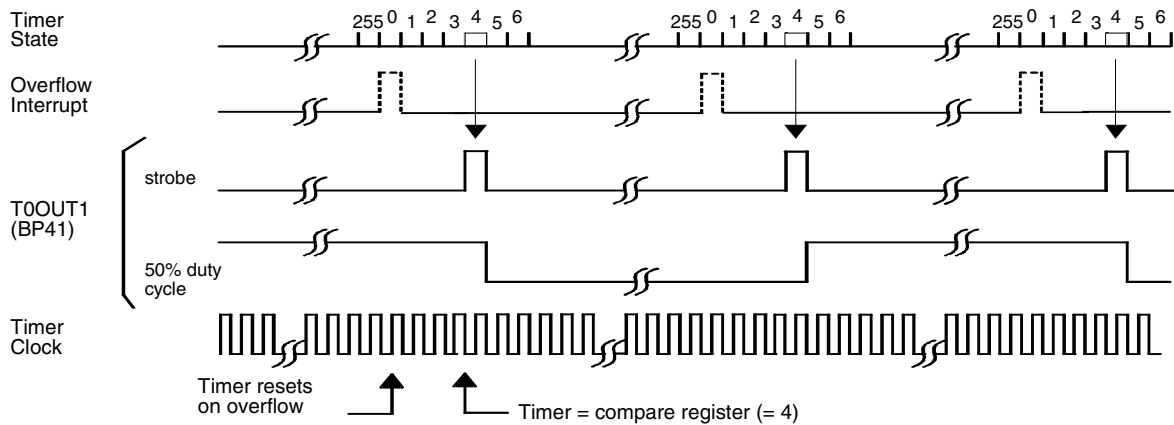

3.5.3.7 *Timer 0 Counter Reload Modes (Strobe and 50% Duty Cycle)*

As in the free running mode, the counter can also be clocked from either an external signal on BP40 or from an internal clock source. In this mode, the counter repetition period is completely defined by the contents of the compare register (T0CP) (see Figure 3-15). The counter counts up with the selected clock frequency. When it reaches the value held in the compare register, the counter then returns to the zero state. At the same time, depending on the selected timer mode, the BP41 either toggles or generates a strobe pulse. If the Timer 0 interrupt is unmasked, a compare interrupt is also generated.

The resultant output frequency $f_{OUT} = f_{IN}/2 \times (n+1)$ where $n = \text{compare value} (n = 1 - 255)$.

Figure 3-15. Timer 0 Counter Reload Mode

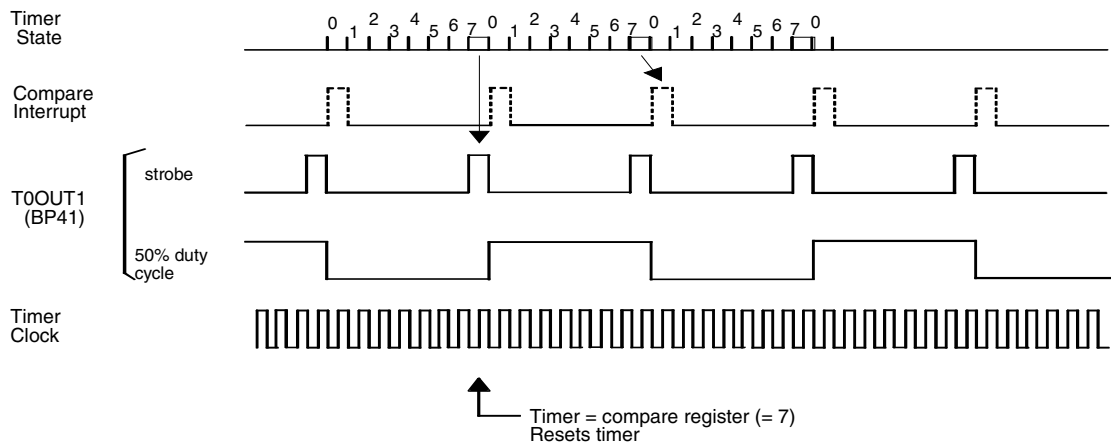

3.5.3.8 Melody Mode (with/without Modulation)

The non-modulated melody mode is identical to the auto-reload counter (50% duty cycle) mode. The melody tone frequency appearing on BP41 and/or BP40 is determined in exactly the same way as the value written into the comparator register. In the modulated melody mode, the ATAR510 generates two output signals, a melody tone and an envelope pulse (see Figure 3-16). The tone frequency output on BP41 is generated in exactly the same way as in the simple melody mode. While the envelope pulse on BP40 is a single pulse of a clock period in duration which appears shortly after loading the compare value into the compare register. In this mode, an analog switch is activated between the BP40 and BP41 outputs (see Figure 3-17). With the external capacitor connected, the resultant signal on BP41 exhibits a melody chime effect with an exponential decay.

Figure 3-16. Modulated Melody Mode

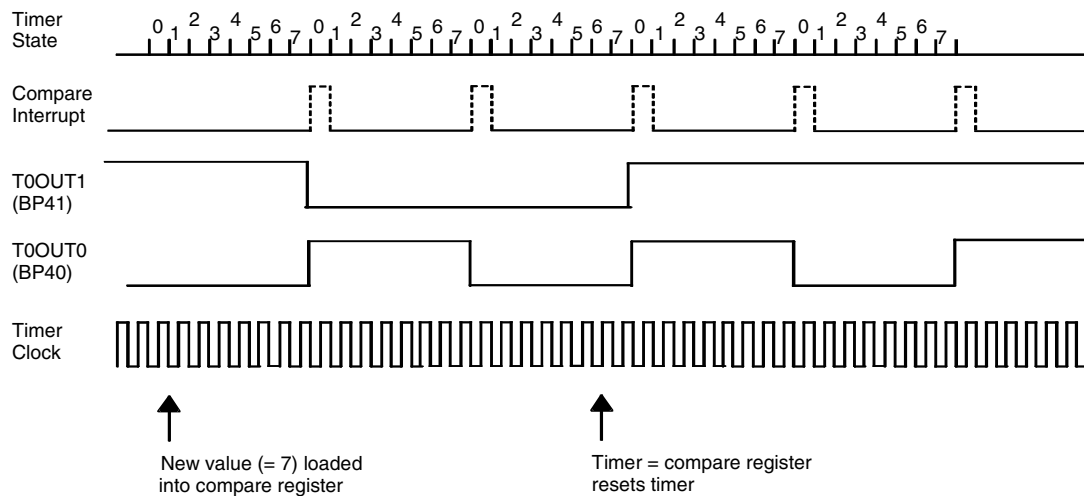
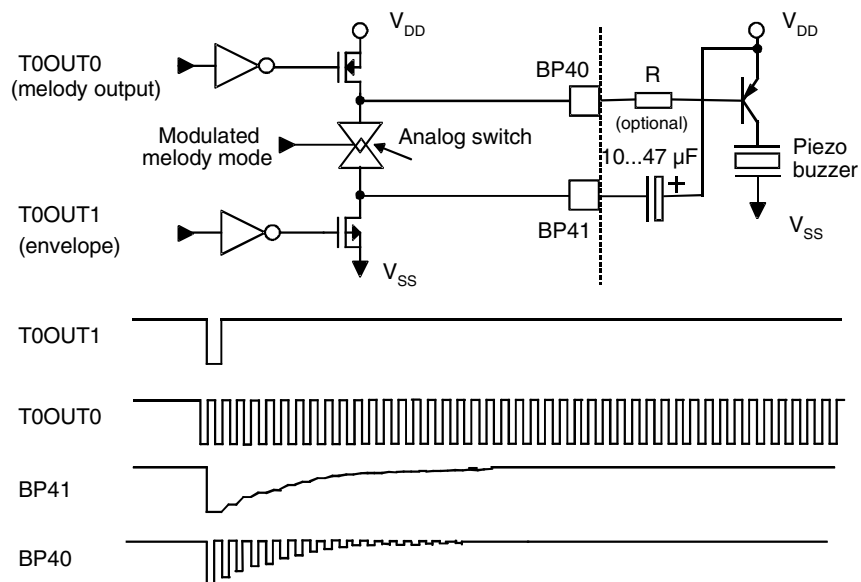

Figure 3-17. Modulated Melody Output Circuit



3.5.3.9 Timer 0 Pulse Width Modulation Mode

A pulse width modulated (PWM) signal exhibits a fixed repetition frequency and a variable mark space ratio. It is often used as a simple method for D/A conversion, where the high period is proportional to the digital value to be converted. Therefore by connecting a simple low-pass RC network to the PWM signal, the analog value can be retrieved.

Timer 0 generates the PWM signal by comparing the state of the free running up counter with the contents of the compare register (see Figure 3-18). If the result is less than the compare register value, then the BP41 output is high. If the result is greater or equal to the compare register value, then the BP41 output is set low. Thus, the high phase of the PWM signal is directly proportional to the compare register contents. A total of 256 possible discrete mark space ratios can be generated ranging from a continuous low signal over a variable pulse width signal to a continuous high signal. The PWM signal has a repetition period of 256 clocks, an interrupt (if unmasked) being generated on every overflow event. Care should be taken if the SYSCL clock is used as the PWM clock source because it may stop if the CPU goes into SLEEP mode (see section “Power-Down Modes”).

Figure 3-18. Timer 0 Pulse Width Modulation

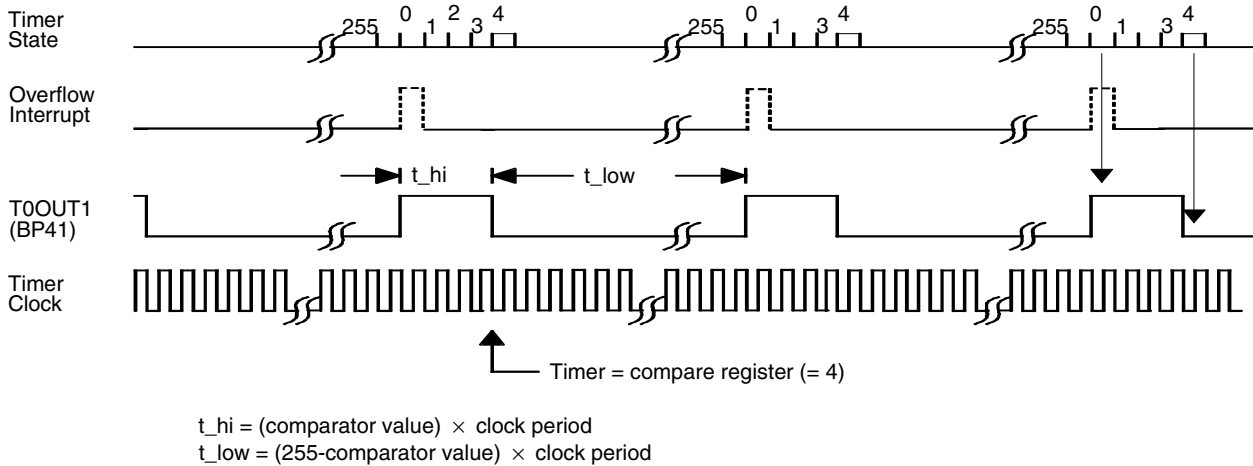

3.5.3.10 Pulse Density Modulation Mode

Pulse density modulation (PDM) is also used for simple D/A conversion. Unlike the PWM signal where the high and low signal phases are always continuous during a single repetition cycle, the PDM distributes these evenly as a series of pulses (see Figure 3-19 on page 47). This has the advantage that, if used together with an RC smoothing filter for D/A conversion, either the ripple is less than the PWM, or, for a corresponding ripple error, the filter components can be smaller or the clock frequency lower. To generate the PDM output on BP41, the pulse density is controlled by the contents of the compare register in the same way as the PWM generation. Each of the pulses has a width equal to the counter clock period.

Figure 3-19. An Example 4-bit PWM/PDM Comparison

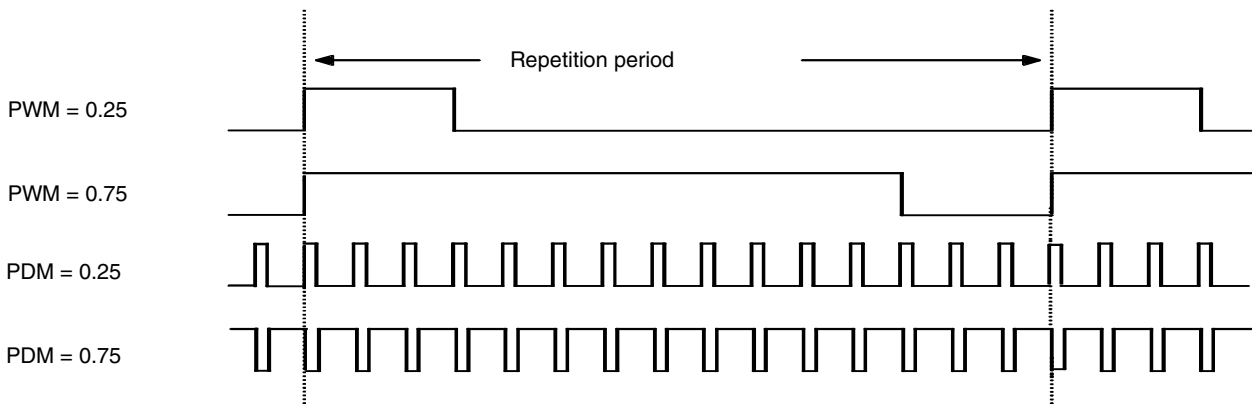

3.5.3.11 *Period Measurement Modes (Rising and Falling Edge)*

During the period measurement mode, the counter counts the number of either internal or external clocks in one period of the BP41 input signal (see Figure 3-20). Depending the mode chosen, this will be from rising edge to the next rising edge or conversely, falling edge to the following falling edge. On the trigger edge, the counter state is loaded into the capture register and subsequently reset. The measured value remains in the capture register until overwritten by the following measured value. Interrupts can be generated by either an overflow condition or an end-of-measurement (EOM) event. An EOM event signals to the CPU that a new measured value is present in the capture register and can be read, if required.

Figure 3-20. Period Measurement

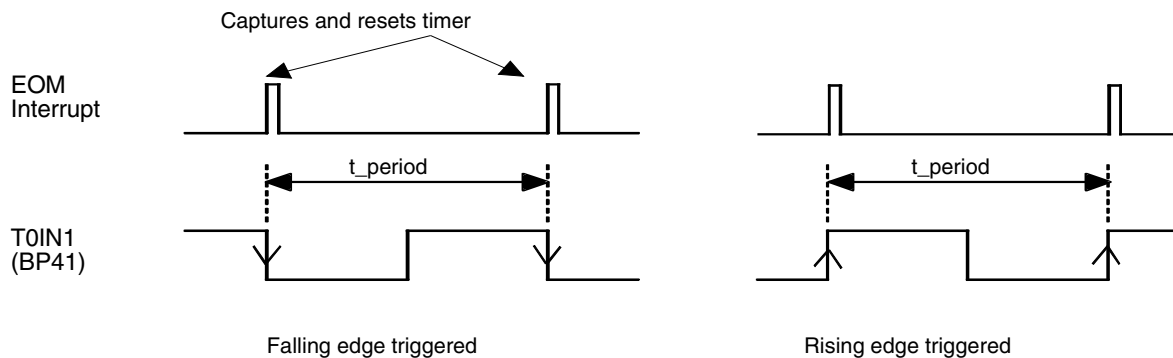

3.5.3.12 *Pulse Width Measurement Modes (High and Low)*

In this mode, the selected clock source is gated to the counter for the duration of each input pulse received on BP41 (see Figure 3-21 on page 48). Whether the measurement takes place during the high or low phase depends on the selected mode. At the end of each pulse, the counter state is loaded into the capture register and subsequently reset. Interrupts can be generated by either an overflow condition or an end-of-measurement (EOM) event. An EOM event signals the CPU that a new measured value is present in the capture register and can be read if required.

Figure 3-21. Pulse Width Measurement

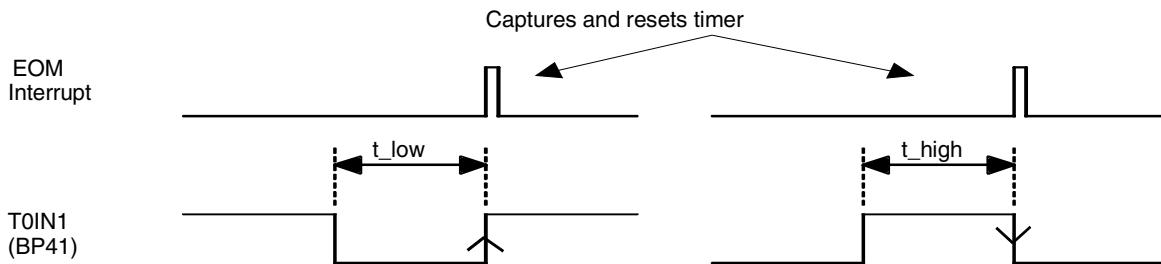

3.5.3.13 Phase Measurement Mode

This mode allows the Timer 0 to measure the phase misalignment between two 1:1 mark space ratio input signals connected to the BP40 and BP41 pins (see Figure 3-22). The counter clock is gated with the phase misalignment period (t_p), during which time the counter increments with the selected clock frequency. This misalignment period is defined as the period during which BP40 is high and BP41 is low. Capturing and resetting of the counter always takes place on the rising edge of BP41. The measured value remains in the capture register until overwritten by the next measurement. Interrupts can be generated by either an overflow condition or an end-of-measurement (EOM) event. An EOM event signals to the CPU that a new measured value is present in the capture register and can be read, if required.

Figure 3-22. Phase Measurement

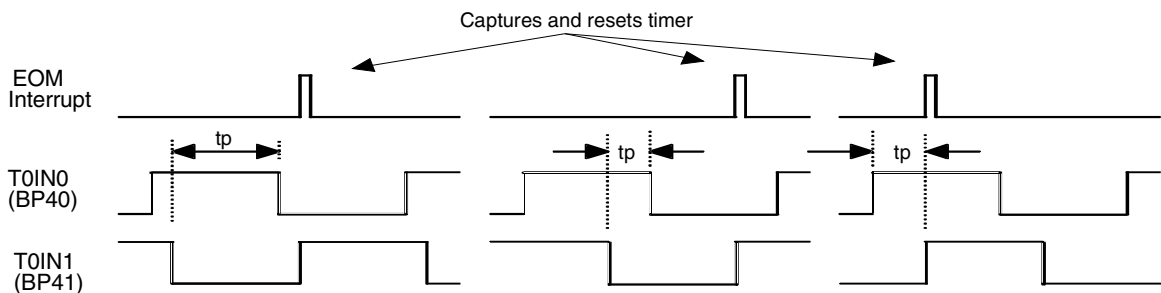

3.5.3.14 Position Measurement Mode

This mode is intended for the evaluation of positional sensors with bi-phase output signals. Figure 3-23 illustrates a typical positional sensor system which delivers both incremental positional stepping signals and also directional information. The direction can be deduced from the relative phase of the two signals. Therefore if BP40 is high on the rising edge of BP41, the moving mask travels to the left and if it is low then it travels to the right. The direction (left/right) information is used to set the direction of the up/down counter which enables the BP40 pulses to be counted. Assuming that the system has been reset on a reference position, the counter will always hold the absolute current position of the moving mask. This can be read by the CPU if necessary. This mode is the only one in which the counter is allowed to decrement. Therefore, in this case it is possible for both an underflow or an overflow to occur. The overflow interrupt (if unmasked) will trigger on either of these conditions while the compare interrupt on the other hand will only trigger if the counter is counting upwards. To differentiate between an overflow or underflow, the compare value can be set to '0' hex, for example. An overflow would then set both the overflow and compare status flags while an underflow sets the overflow status flag only.

Figure 3-23. Position Measurement Mode

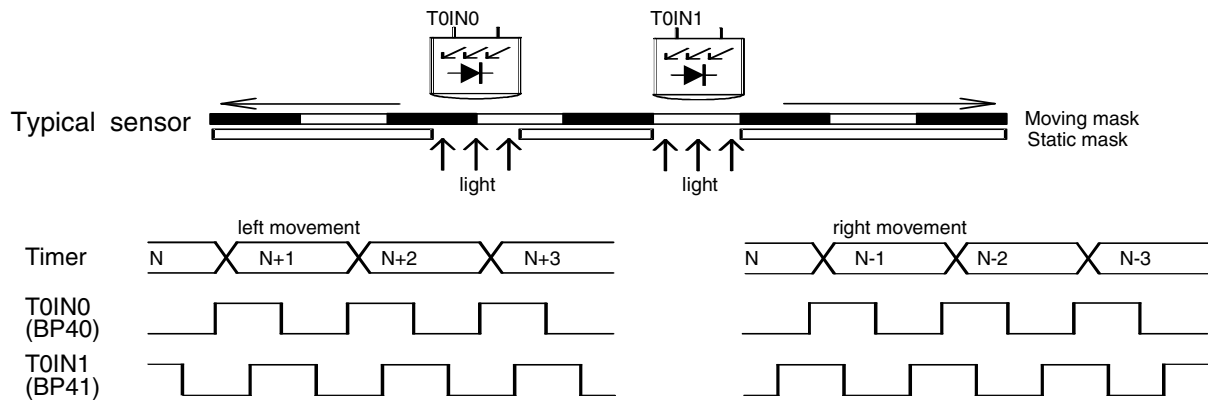

3.5.4 Timer 1 Modes

Timer 1 is meant to perform event counting and timing functions (see Figure 3-11 on page 35). It has, unlike the Timer 0, no gated clock or externally triggered capture modes. The counter counts up with an internal or external clock, depending on the state of the Timer 1 Control Register (T1CR) and the Timer/Counter Clock Control Register (TCCR) and generates a compare interrupt whenever the counter matches Timer 1 compare register. This is the only Timer 1 interrupt source. Masking can be performed using the mask bit in the Timer 1 Control Register (T1CR) and priority can be defined in the Timer/Counter Interrupt Priority Register (TCIP). The TIM1 pin is used by the Timer 1 either as clock/event input or timer output. I/O control of the Timer 1 pin TIM1 is controlled entirely by the hardware, therefore if the TIM1 is selected as an external clock or event source (in the TCCR), there can be no Timer 1 signal output. In this case, the timer would be used solely to generate interrupts.

In autostop operation, the Timer 1 will halt both itself and Timer 0 whenever the Timer 1 compare value is reached. This feature can be used for example to generate an exact burst of pulses. Both timers will remain stopped until restarted. Restarting is performed in the normal way by setting the appropriate control bits in the Timer/Counter Mode Register (TCM0).

3.5.4.1 Timer 1 Mode Register (T1M0)

Subport address (indirect write access): '2'hex of Port address '9'hex

	Bit 3	Bit 2	Bit 1	Bit 0	
T1M0	T1M03	T1M02	T1M01	T1M00	Reset value: 1111b

T1M03 ... 0 - Timer 1 Mode Code

Table 3-16. Timer 1 Mode Register (T1MO)

Code 3 2 1 0	Function	Compare Interrupt
x x 0 0	Counter free running (50% duty cycle)	yes
x x 0 1	Counter auto reload (50% duty cycle)	yes
x x 1 0	Pulse width modulation	yes
x x 1 1	Counter auto-reload (strobe output)	yes
x 0 x x	Increment on falling edge of clock	–
x 1 x x	Increment on rising edge of clock	–
1 x x x	Normal operation (no autostop)	yes
0 x x x	Autostop operation (Timer 1 stops Timer 2)	yes

3.5.4.2 Timer 1 Control Register (T1CR)

The T1CR is responsible for the predivision of the selected Timer 1 input clock (see TCCR). It can be divided or used directly as clock for the up counter. Bit 0 is the mask bit for the Timer 1 interrupt.

Subport address (indirect write access): '3'hex of Port address '9'hex

	Bit 3	Bit 2	Bit 1	Bit 0	
T1CR	T1FS3	T1FS2	T1FS1	T1IM	Reset value: 1111b

- T1FS3 ... 1 - Timer 1 Prescaler Division Factor Code
T1IM - Timer 1 Interrupt Mask

Table 3-17. Timer 1 Control Register (T1CR)

Code 3 2 1 0	Function
x x x 1	Timer 1 interrupt disabled
x x x 0	Timer 1 interrupt enabled
0 0 0 x	Timer 1 prescaler divide by 256
0 0 1 x	Timer 1 prescaler divide by 128
0 1 0 x	Timer 1 prescaler divide by 64
0 1 1 x	Timer 1 prescaler divide by 32
1 0 0 x	Timer 1 prescaler divide by 16
1 0 1 x	Timer 1 prescaler divide by 8
1 1 0 x	Timer 1 prescaler divide by 4
1 1 1 x	Timer 1 prescaler bypassed

3.5.4.3 Timer 1 Compare Register (T1CP) - Byte Write

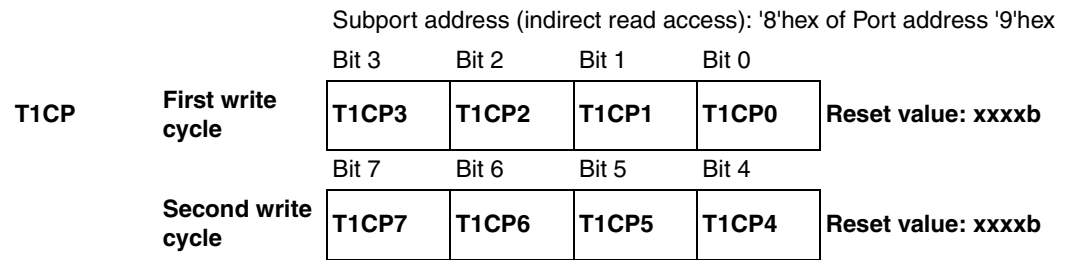

T1CP3 ... T1CP0 - Timer 1 Compare Register Data (low nibble) - first write cycle

T1CP7 ... T1CP4 - Timer 1 Compare Register Data (high nibble) - second write cycle

The compare register T1CP is 8 bits wide and must be accessed as a byte wide subport (see Section 3.1 on page 20). The data is written low nibble first, followed by the high nibble. Any timer interrupts are automatically suppressed until the complete compare value has been transferred.

3.5.4.4 Timer 1 Capture Register (T1CA) - Byte Read

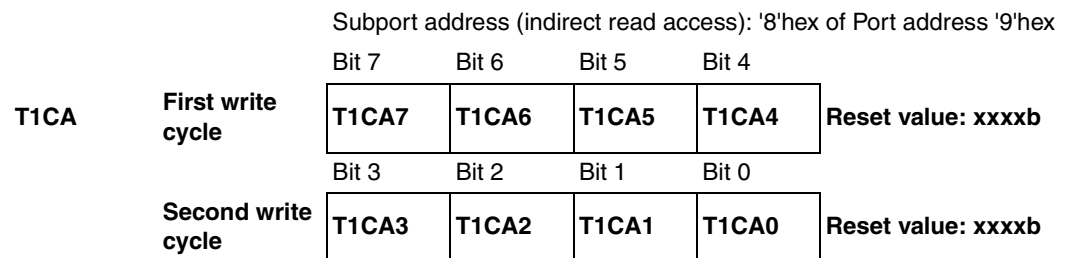

T1CA7 ... T1CA4 - Timer 1 Capture Register Data (high nibble) - first read cycle

T1CA3 ... T1CA0 - Timer 1 Capture Register Data (low nibble) - second read cycle

The 8-bit capture register T1CA is read as byte wide subport. Note, however, unlike the writing to the compare register, the high nibble is read first followed by low nibble. The 8-bit timer state is captured on reading the first nibble and held until the complete byte has been read. During this transfer, the timer is free to continue counting. The previous capture value will be held until the timer is restarted again.

3.5.4.5 Timer 1 Counter Free Running (50% Duty Cycle)

In the free running counter mode, the counter counts up with either an internal or external clock and cycles through all 256 timer states. On the clock following a match between the compare register (T1CR) and the counter, a compare interrupt (if unmasked) is generated and the TIM1 pin is toggled (see Figure 3-24).

Figure 3-24. Timer 1 Counter Free Running (50% Duty Cycle)

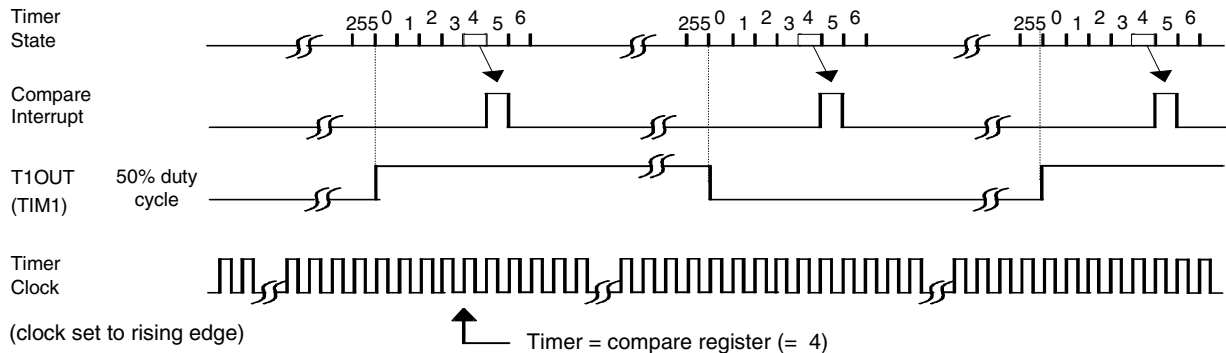

3.5.4.6 Timer 1 Counter Auto Reload (Strobe and 50% Duty Cycle)

In the auto-reload mode, the counter counts up with either an internal or external clock. On the clock cycle following a match between the compare register (T1CR) and the counter, a compare interrupt (if unmasked) is generated. The TIM1 output is either strobed or toggled and the counter reset (see Figure 3-25). Therefore, the counter cycle period is defined by the contents of the compare register. In 50% duty cycle mode the frequency of TIM1 is:

$$f_{TIM1} = f_{in}/2(n+1) \quad \text{where the compare value } (n) = 1 \dots 255$$

Figure 3-25. Timer 1 Counter Auto Reload

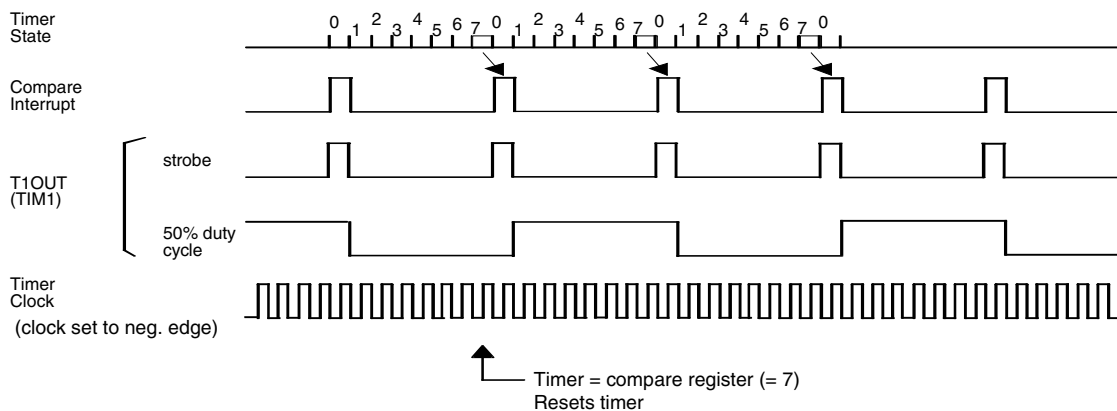

3.5.4.7 Timer 1 Pulse Width Modulation

The Timer 1 generates the PWM signal by comparing the state of the free running up counter with the contents of the compare register (see Figure 3-26). If the result is less or equal to the compare register value, then the TIM1 output is high. If the result is greater than the compare register value, then the TIM1 output is set low. Thus, the high phase of the PWM signal is directly proportional to the compare register contents. A total of 256 possible discrete mark space ratios can be generated ranging from a continuous low signal over a variable pulse width signal. The PWM signal has a repetition period of 256 clock periods, an interrupt (if unmasked) being generated on every compare event.

Care should be taken if SYSCL is used as the PWM clock source. The PWM output may stop if the CPU goes into SLEEP made depending on the programming of the NSTOP bit in the CM-register. If using this mode of operation it is recommended to set the bit NSTOP =1.

Figure 3-26. Timer 1 Pulse Width Modulation

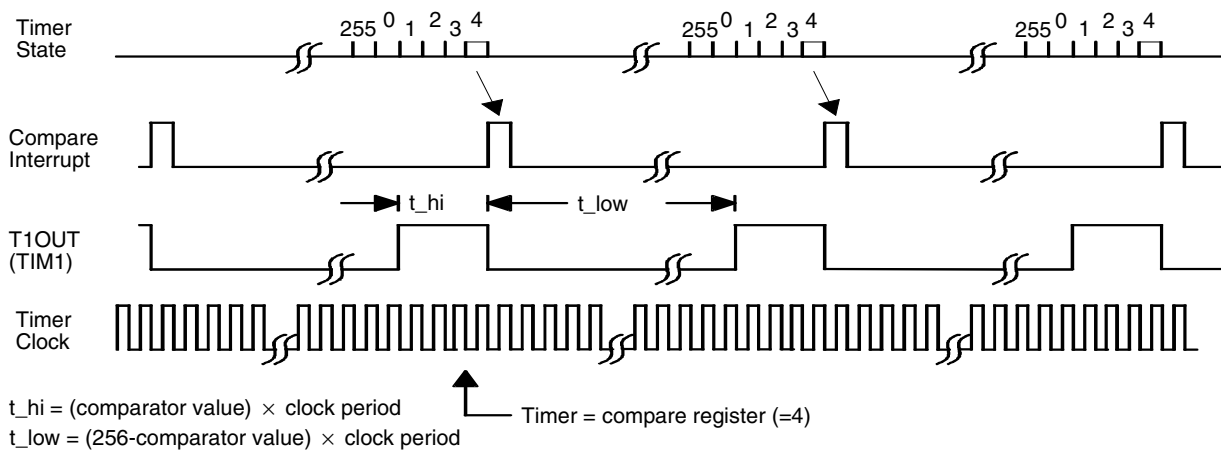

3.6 Buzzer Module

The buzzer is a 4 stage frequency divider which divides the SUBCL and depending on the state of the Buzzer Control Register (BZCR) can output one of four frequencies. An external piezo or buzzer can be driven by the complementary buzzer outputs (BUZ and NBUZ) which are directed to Port 4 (BP42 and BP43) under control of the Timer/Counter I/O Register (TCIOR) as shown in Figure 3-12. When the buzzer is switched off, both of the buzzer outputs take up the same logical state. This is controlled by the BZOP bit of the BZCR.

Figure 3-27. Buzzer Module

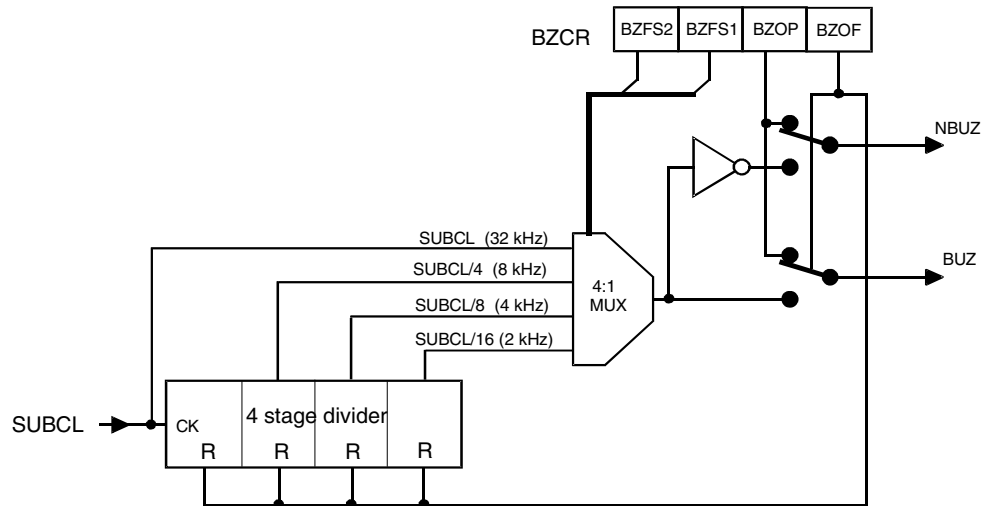

3.6.0.8 Buzzer Control Register (BZCR)

Subport address (indirect write access): 'A'hex of Port address '9'hex

	Bit 3	Bit 2	Bit 1	Bit 0	
BZCR	BZFS2	BZFS1	BZOP	BZOF	Reset value: 1111b

- BZFS2,BZFS2 - Buzzer Frequency Select code
- BZOP - Buzzer Output Stop State
- BZOF - Buzzer off/on

Table 3-18. Buzzer Control Register (BZCR)

Code 3 2 1 0	Function
x x x 0	Buzzer on
x x x 1	Buzzer off
x x 0 x	Buzzer output stop state: BP42 = BP43 = low
x x 1 x	Buzzer output stop state: BP42 = BP43 = high
0 0 x x	Buzzer frequency: 32 kHz (= SUBCL)
0 1 x x	Buzzer frequency: 8 kHz (= SUBCL/4)
1 0 x x	Buzzer frequency: 4 kHz (= SUBCL/8)
1 1 x x	Buzzer frequency: 2 kHz (= SUBCL/16)

Figure 3-28. Buzzer Waveform

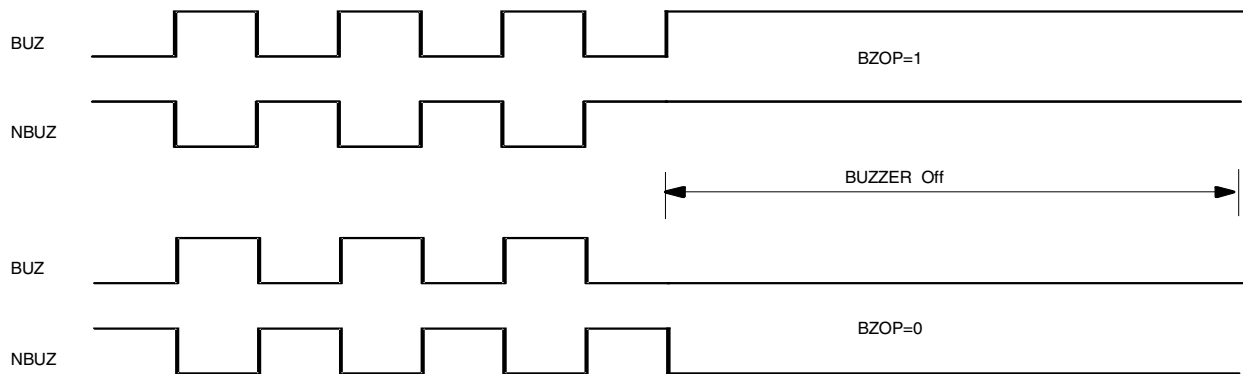

3.7 Emulation

Figure 3-29. Emulation

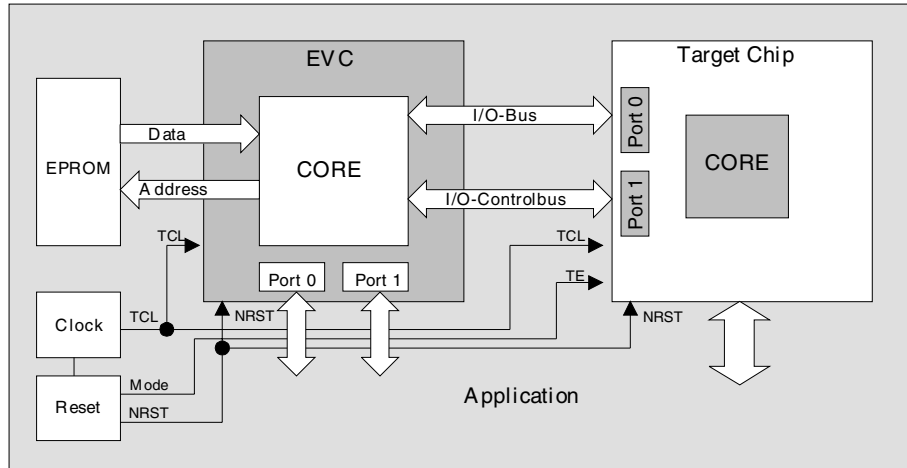

All MARC4 controllers have a special emulation mode. It is activated by setting the TE pin to logic HIGH level after reset. In this mode, the internal CPU core is inactive and the I/O bus is available via port 0 and port 1 to allow the emulator the access to the on-chip peripherals. The emulator contains a special emulation CPU with a MARC4 core and additional breakpoint logic and takes over the core function. The basic function of the emulator is to evaluate the customer's program and hardware in real-time.

3.8 MTP Support

The ATAM510 (T48C510) from Atmel provides full pin compatible multi-time programmable (MTP) support for the ATAR510. This device is equipped with EEPROM memory and allows in-system testing and real-time execution of up to 4-Kbyte application programs along with nonvolatile configuration of the ATAR510 mask option settings.

For further details please refer to the ATAM510 (T48C510) datasheet.

3.9 Noise Considerations

When designing the microcontroller based application, several factors should be taken into consideration to increase noise immunity and reduce electromagnetic emission (EME). Many such potential problems can be avoided by careful layout of the printed circuit board (PCB). The PCB contains many parasitic components which at first sight are not apparent. PCB tracks can act as antennas or as coupling capacitors. Long stretches of parallel tracks and long high frequency signal lines should thus be avoided wherever possible to minimize the chance of picking up or transmitting unwanted signals.

3.9.1 Noise Immunity

The following guidelines will increase system noise immunity:

- Unconnected inputs should not be left open. If port pins are not required then it is recommended to set pull-up or pull-down options on these pins.
- Special care should be taken when laying out the PCB that interrupt, reset and clock signal lines are kept short and are carefully shielded or have sufficient spacing from other on board noise generating sources.
- A quartz crystal should always be located right next to the microcontroller crystal oscillator terminals (OSCIN and OSCOUT), the connections being always very short. This avoids, not only signal coupling onto the clock source, but can also reduces EME.
- PCB's should, where economically possible, be equipped with adequate ground planes.
- The microcontroller power supply should be decoupled with an electrolytic capacitance (approximate 10 μ F) in parallel with a ceramic capacitance (approximate 100 nF) situated as close to the microcontroller device as possible.

3.9.2 Electromagnetic Emissions

Electromagnetic emissions are caused by rapidly changing electrical currents (di/dt) in long antenna like connection lines and cables. This can result in electrical interference on other telecommunication devices. These current spikes are more often than not present in the system power supply lines and driver signal lines.

The following guide will help to reduce EME:

- Keep the length of PCB current switching signal tracks to a minimum..
- Adopt a PCB star power routing system connected at one point.
- Many of the microcontroller port outputs can be configured with several drive strengths. This means that a high drive output will switch a signal faster than for example a standard drive output. The resulting change in current in the signal and power lines will also increase, causing an increase in EME. So wherever speed and drive current is not necessary the ports should be configured with the lowest drive possible.
- If possible, write the application program to avoid multiple outputs switching at any instant.
- Cables can be equipped with ferrite rings to slow current spikes or the system can be encased in a grounded conducting casing.

4. Absolute Maximum Ratings

Voltages are given relative to V_{SS} .

Stresses beyond those listed under “Absolute Maximum Ratings” may cause permanent damage to the device. This is a stress rating only and functional operation of the device at these or any other conditions beyond those indicated in the operational sections of this specification is not implied. Exposure to absolute maximum rating conditions for extended periods may affect device reliability.

All inputs and outputs are protected against high electrostatic voltages or electric fields. However, precautions to minimize the build-up of electrostatic charges during handling are recommended. Reliability of operation is enhanced if unused inputs are connected to an appropriate logic voltage level (e.g., V_{DD}).

Parameters	Symbol	Value	Unit
Supply voltage	V_{DD}	-0.3 to +7	V
Input voltage (on any pin)	V_{IN}	$V_{SS} - 0.3 \leq V_{IN} \leq V_{DD} + 0.3$	V
Output short circuit duration	t_{short}	indefinite	s
Operating temperature range	T_{amb}	-40 to +85	°C
Storage temperature range	T_{stg}	-65 to +150	°C
Thermal resistance (SSO44)	R_{thJA}	110	K/W
Soldering temperature ($t \leq 10$ s)	T_{slid}	260	°C

5. DC Operating Characteristics

Supply voltage $V_{DD} = 5$ V, $V_{SS} = 0$ V, $T_{amb} = -40^{\circ}\text{C}$ to 85°C unless otherwise specified.

Typical values relate to $V_{DD} = 5$ V, $T_{amb} = 25^{\circ}\text{C}$ and are for reference only.

Parameters	Test Conditions	Symbol	Min.	Typ.	Max.	Unit
Power Supply						
Supply Voltage		V_{DD}	2.2		6.2	V
Active current	CPU running TestROM at SYSCL_iRC3	I_{DD}		200	500	μA
Quotient $I_{DD}/\text{SYSCL_iR3}$	CPU running TestROM at SYSCL_iRC3	I_{DDQ}		0.25	0.5	$\mu\text{A}/\text{kHz}$
Halt current	CPU in sleep mode, NSTOP = 0	I_{Halt}		0.1	0.5	μA
Power-on Reset Threshold Voltage						
POR threshold voltage		V_{POR}	0.8	1.0	1.5	V
Schmitt Trigger Input Voltage: (All Inputs Except Port 5, 7 and C)						
Negative-going threshold voltage	$V_{DD} = 2.4$ to 6.2 V	V_{T-}	V_{SS}		$0.4 \times V_{DD}$	V
Positive-going threshold voltage	$V_{DD} = 2.4$ to 6.2 V	V_{T+}	$0.55 \times V_{DD}$		V_{DD}	V
Hysteresis ($V_{T+} - V_{T-}$)	$V_{DD} = 2.4$ to 6.2 V	V_H		$0.1 \times V_{DD}$		
Input Pins: NRST and TE						
Input voltage LOW	$V_{DD} = 2.4$ to 6.2 V	V_{IL}	V_{SS}		$0.2 \times V_{DD}$	V
Input voltage HIGH	$V_{DD} = 2.4$ to 6.2 V	V_{IH}	$0.8 \times V_{DD}$		V_{DD}	V

Note: The total sum of all port static output currents must not exceed 100 mA.

The sum of all port currents switched at any instant (di/dt) must not exceed 30 mA.

5. DC Operating Characteristics (Continued)

Supply voltage $V_{DD} = 5\text{ V}$, $V_{SS} = 0\text{ V}$, $T_{amb} = -40^{\circ}\text{C}$ to 85°C unless otherwise specified.

Typical values relate to $V_{DD} = 5\text{ V}$, $T_{amb} = 25^{\circ}\text{C}$ and are for reference only.

Parameters	Test Conditions	Symbol	Min.	Typ.	Max.	Unit
Input NRST with Pull-up Resistor						
Input LOW current	$V_{DD} = 2.4\text{ V}$, $V_{IL} = V_{SS}$ $V_{DD} = 5.0\text{ V}$	I_{IL}	-1.0 -5	-1.5 -10	-3.0 -18	μA μA
Input TE with Pull-down Resistor						
Input HIGH current	$V_{DD} = 5.0\text{ V}$	I_{IH}	1	1.4	2	mA
All Bi-directional Ports and TIM1						
Input voltage LOW	$V_{DD} = 2.4\text{ to }6.2\text{ V}$	V_{IL}	V_{SS}		$0.2 \times V_{DD}$	V
Input voltage HIGH	$V_{DD} = 2.4\text{ to }6.2\text{ V}$	V_{IH}	$0.8 \times V_{DD}$		V_{DD}	V
Dynamic input LOW current (pull-up)	$V_{DD} = 2.4\text{ V}$, $V_{IL} = V_{SS}$ $V_{DD} = 5.0\text{ V}$	I_{IL}	-1.0 -5	-1.5 -10	-3.0 -18	μA μA
Dynamic input HIGH current (pull-down)	$V_{DD} = 2.4\text{ V}$, $V_{IH} = V_{DD}$ $V_{DD} = 5.0\text{ V}$	I_{IH}	1.0 5	1.5 10	2.5 18	μA μA
Output LOW current standard/low drive	$V_{DD} = 2.4\text{ V}$ $V_{OL} = 0.2 \times V_{DD}$ $V_{DD} = 5.0\text{ V}$	I_{OL}	1 6	2 9	4 13	mA mA
Output LOW current high drive	$V_{DD} = 2.4\text{ V}$ $V_{OL} = 0.2 \times V_{DD}$ $V_{DD} = 5.0\text{ V}$	I_{OL}	2 12	4 18	7 30	mA mA
Output HIGH current low drive	$V_{DD} = 2.4\text{ V}$ $V_{OH} = 0.8 \times V_{DD}$ $V_{DD} = 5.0\text{ V}$	I_{OH}	-0.3 -2.0	-0.5 -2.5	-1.5 -3.3	mA mA
Output HIGH current standard drive	$V_{DD} = 2.4\text{ V}$ $V_{OH} = 0.8 \times V_{DD}$ $V_{DD} = 5.0\text{ V}$	I_{OH}	-1 -6	-2 -8	-4 -13	mA mA
Output HIGH current high drive	$V_{DD} = 2.4\text{ V}$ $V_{OH} = 0.8 \times V_{DD}$ $V_{DD} = 5.0\text{ V}$	I_{OH}	-2 -12	-4 -15	-8 -30	mA mA
Bi-directional Port BP4, BP5, BP7, BPA, BPB and BPC						
Input LOW current Static pull-up (30 k Ω)	$V_{DD} = 2.4\text{ V}$ $V_{DD} = 5.0\text{ V}$	I_{IL} I_{IL}	-15 -100	-25 -150	-45 -220	μA μA
Input HIGH current static pull-down (30 k Ω)	$V_{DD} = 2.4\text{ V}$ $V_{DD} = 5.0\text{ V}$	I_{IH} I_{IH}	15 100	25 150	45 220	μA μA
Input LOW current static pull-up (4 k Ω)	$V_{DD} = 2.4\text{ V}$ $V_{DD} = 5.0\text{ V}$	I_{IL} I_{IL}	-0.2 -1	-0.3 -1.35	-0.5 -2	mA mA
Input HIGH current static pull-down (4 k Ω)	$V_{DD} = 2.4\text{ V}$, $V_{IL} = V_{SS}$ $V_{DD} = 5.0\text{ V}$	I_{IH} I_{IH}	0.15 1	0.25 1.4	0.5 2	mA mA

Note: The total sum of all port static output currents must not exceed 100 mA.

The sum of all port currents switched at any instant (di/dt) must not exceed 30 mA.

6. AC Characteristics

Supply voltage $V_{DD} = 2.4\text{ V}$ to 6.2 V , $V_{SS} = 0\text{ V}$, $T_{amb} = -40^{\circ}\text{C}$ to 85°C unless otherwise specified.
 Typical values relate to $V_{DD} = 5\text{ V}$, $T_{amb} = 25^{\circ}\text{C}$ and are for reference only.

Parameters	Test Conditions	Symbol	Min.	Typ.	Max.	Unit
Reset Timing						
Power-on reset delay	$V_{DDu} V_{POR}$	t_{POR}		80		ms
NRST input LOW time		t_{NRST}	4			μs
Interrupt Request Input Timing						
Interrupt request LOW time		t_{IRL}	50			ns
Interrupt request HIGH time		t_{IRH}	50			ns
Internal RC Oscillator (For Additional Characteristics see Figure 7-8 on page 64 to Figure 7-10 on page 64)						
Standby current of iRC0	CPU in SLEEP mode, SC = 0011b, CM = 1100b	I_{IRC0}		300	500	μA
SYSCL_iRC0	CPU active, SC = 0011b, CM = 1100b	f_{SYSCL}	3.5	7.0	10.5	MHz
Standby current of iRC1	CPU in SLEEP mode, SC = 0111b, CM = 1101b	I_{IRC1}		150	250	μA
SYSCL_iRC1	CPU active, SC = 0111b, CM = 1101b	f_{SYSCL}	1.9	3.0	4.5	MHz
Standby current of iRC2	CPU in SLEEP mode, SC = 1011b, CM = 1110b	I_{IRC2}		100	150	μA
SYSCL_iRC2	CPU active, SC = 1011b, CM = 1110b	f_{SYSCL}	1.4	2.0	3.0	MHz
Standby current of iRC3	CPU in SLEEP mode, SC = 1111b, CM = 1111b	I_{IRC3}		40	70	μA
SYSCL_iRC3	CPU active, SC = 1111b, CM = 1111b	f_{SYSCL}	0.60	0.80	1.3	MHz
Stability	$\Delta V_{DD} = 5\text{ V} \pm 20\%$	df/f_0			± 5	%
System Clock Crystal/Ceramic Oscillator (For Additional Characteristics see Figure 7-2 on page 62)						
Standby current	CPU in SLEEP mode, 4-MHz crystal active	I_{xtal}			125	μA
Start-up time	$V_{DD} = 2.4\text{ V}$	$t_{startup}$		8	10	ms
Stability	$\Delta V_{DD} = 3\text{ V}$ to 5.5 V	df/f_0		0.3	0.5	ppm
RC Oscillator - External Resistor (For Additional Characteristics see Figure 7-5 on page 63 to Figure 7-7 on page 63)						
Standby current	CPU in SLEEP mode, $R_{ext} = 150\text{ k}\Omega (\pm 1\%)$	I_{xRC}			125	μA
Frequency	CPU active, $R_{ext} = 150\text{ k}\Omega$	f_{SYSCL}	1.8	2.0	2.2	MHz
Stability	$V_{DD} = 2.4\text{ V}$ to 5.5 V	df/f_0			± 10	%

Note: 1. Customer mask option (not subject to production test)

6. AC Characteristics (Continued)

Supply voltage $V_{DD} = 2.4\text{ V to }6.2\text{ V}$, $V_{SS} = 0\text{ V}$, $T_{amb} = -40^{\circ}\text{C to }85^{\circ}\text{C}$ unless otherwise specified.
 Typical values relate to $V_{DD} = 5\text{ V}$, $T_{amb} = 25^{\circ}\text{C}$ and are for reference only.

Parameters	Test Conditions	Symbol	Min.	Typ.	Max.	Unit
32-kHz Crystal Oscillator						
Active current	CPU active/running	I_{DD32k}			10	μA
HALT current	CPU in SLEEP mode	I_{HALTx}		1.0	1.5	μA
Start-up time	$V_{DD} = 2.4\text{ V}$	$t_{startup}$			1.5	s
Stability	$\Delta AV_{DD} = 100\text{ mV}$	df/f_0		0.1	0.3	ppm
Integrated input/output capacitances	(1)	C_{IN} C_{OUT}			20 20	pF pF
External Clock Input at SCLIN, TIM1 and T0IN						
SCLIN input clock $f_{SCLIN} = 2 \times f_{SYSCL}$	CPU active, $V_{DD} > 2.4\text{ V}$ rise/fall time $< 50\text{ ns}$, see Figure 7-2 on page 62	f_{SYSCL}		4	8	MHz
TIM1, T0IN input frequency	rise/fall time $< 30\text{ ns}$	f_{IN}			10	MHz

Note: 1. Customer mask option (not subject to production test)

7. Crystal Characteristics

Parameters	Test Conditions	Symbol	Min.	Typ.	Max.	Unit
32-kHz Crystal						
Crystal frequency		f_x		32.768		kHz
Series resistance		RS		30	50	$k\Omega$
Static capacitance		C0		1.5		pF
Dynamic capacitance		C1		3		fF
Load capacitance		C_L	8	10	12.5	pF
System Clock Crystal						
Crystal frequency		f_x	1.5	4	8	MHz
Series resistance		RS		30	50	Ω
Static capacitance		C0		2	4.5	pF
Dynamic capacitance		C1		3	15	fF

Figure 7-1. Crystal Equivalent Circuit

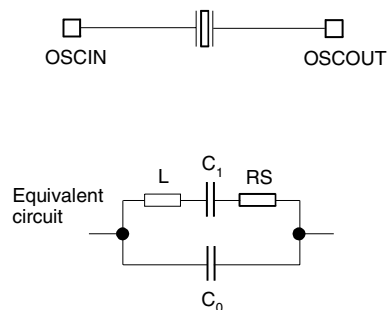

Figure 7-2. Worst Case Minimum/Maximum System Frequency (Using External RC or Crystal oscillator)

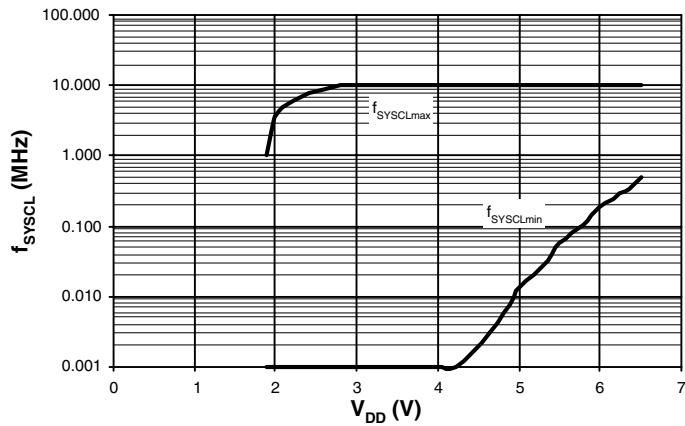

Figure 7-3. $I_{\text{DD}} = f(f_{\text{SYSCL}})$, $V_{\text{DD}} = 3$ V

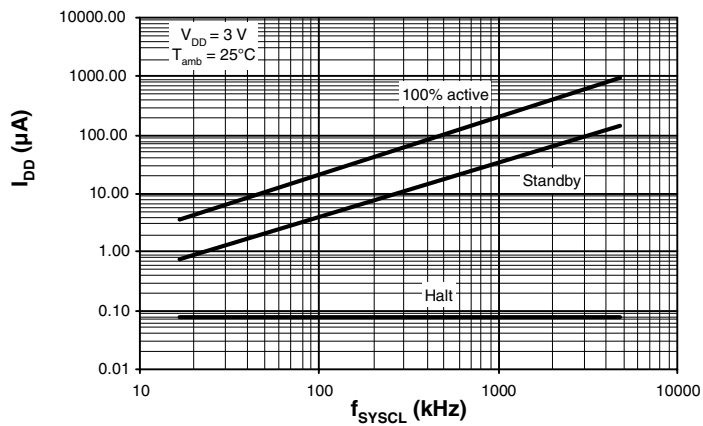

Figure 7-4. $I_{\text{DD}} = f(f_{\text{SYSCL}})$, $V_{\text{DD}} = 5$ V

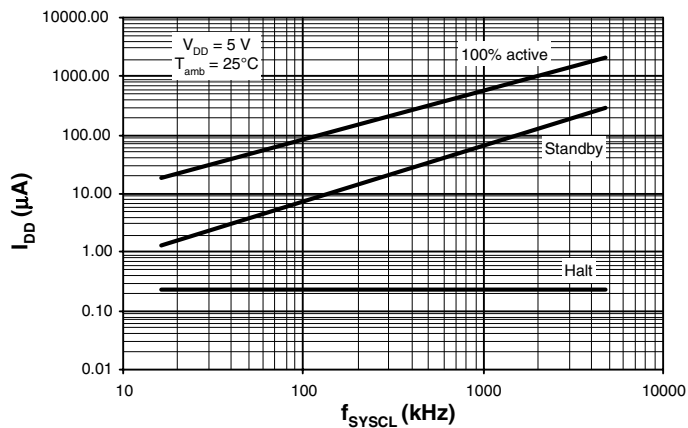

Figure 7-5. $f_{\text{SYSCL}} = f(T_{\text{amb}})$; External RC

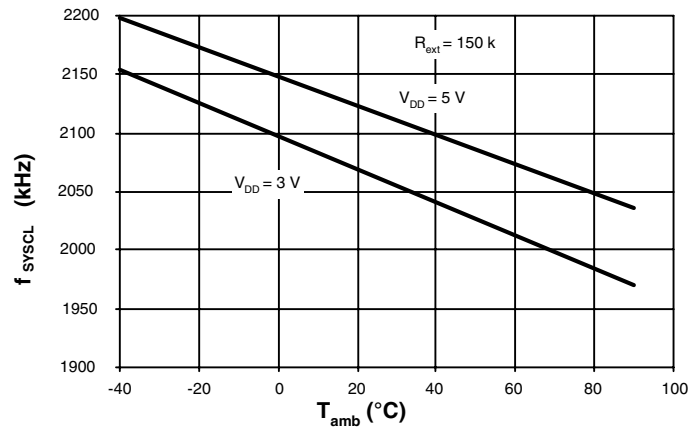

Figure 7-6. $f_{\text{SYSCL}} = f(R_{\text{ext}})$

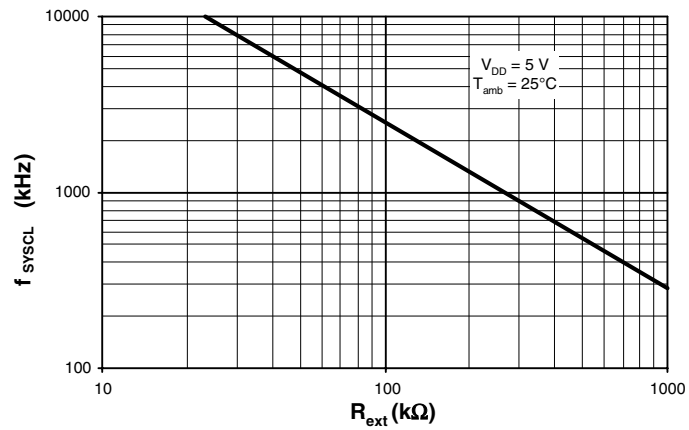

Figure 7-7. $f_{\text{SYSCL}} = f(V_{\text{DD}}, R_{\text{ext}})$

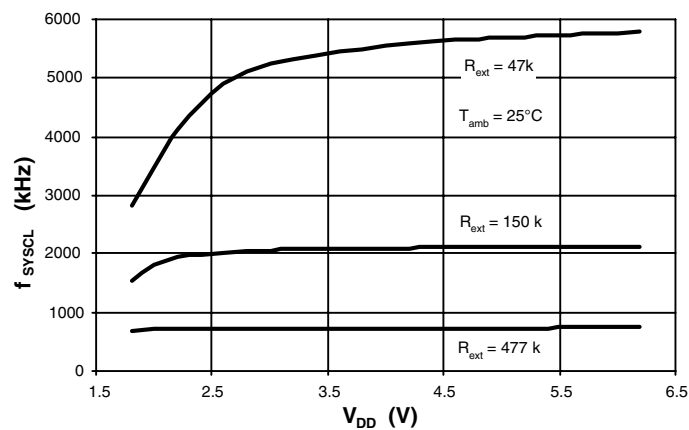

Figure 7-8. $f_{\text{SYSCL}} = f(V_{\text{DD}})$; Internal RC

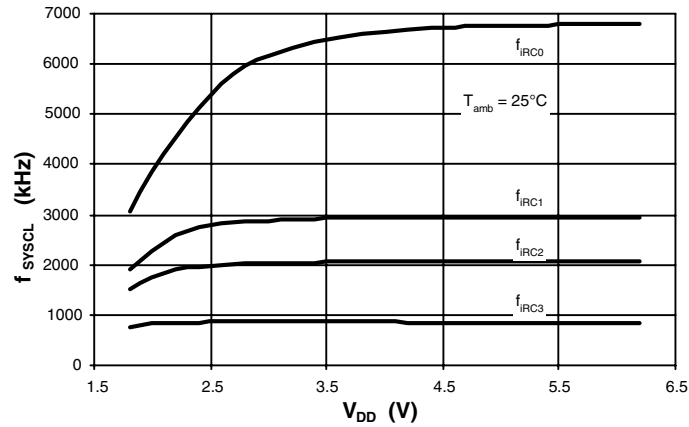

Figure 7-9. $f_{\text{SYSCL}} = f(T_{\text{amb}})$, $V_{\text{DD}} = 3 \text{ V}$

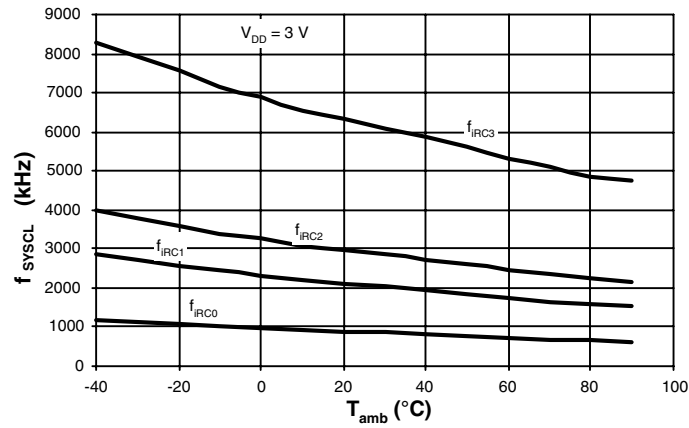

Figure 7-10. $f_{\text{SYSCL}} = f(T_{\text{amb}})$, $V_{\text{DD}} = 5 \text{ V}$

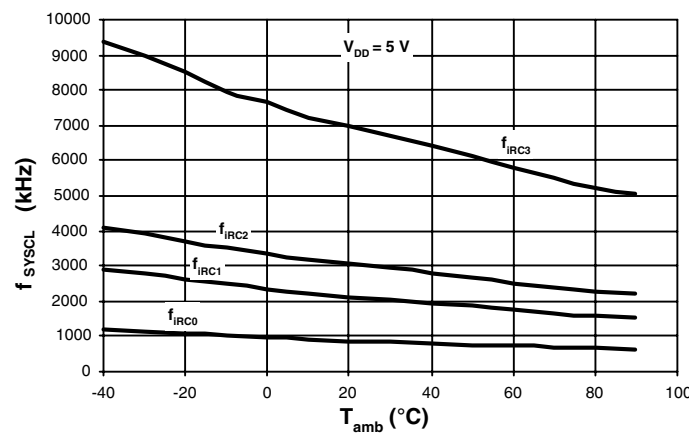

Figure 7-11. Typical High Output Driver, $V_{DD} = 3\text{ V}$

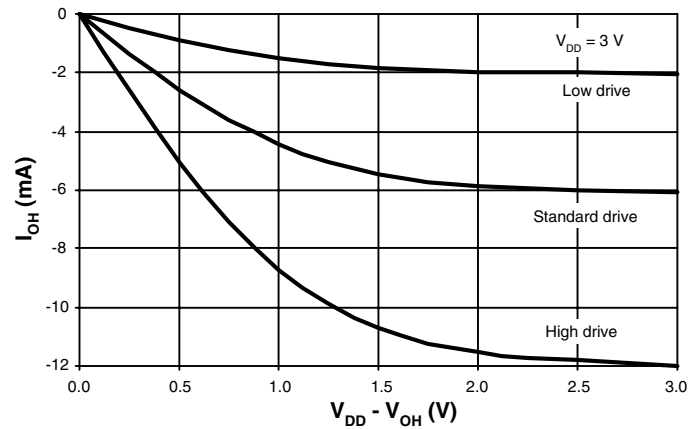

Figure 7-12. Typical Low Output Driver, $V_{DD} = 3\text{ V}$

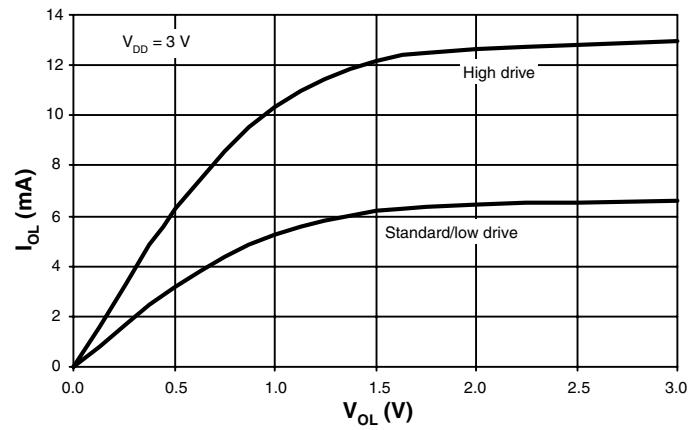

Figure 7-13. Typical Low Output Driver, $V_{DD} = 5\text{ V}$

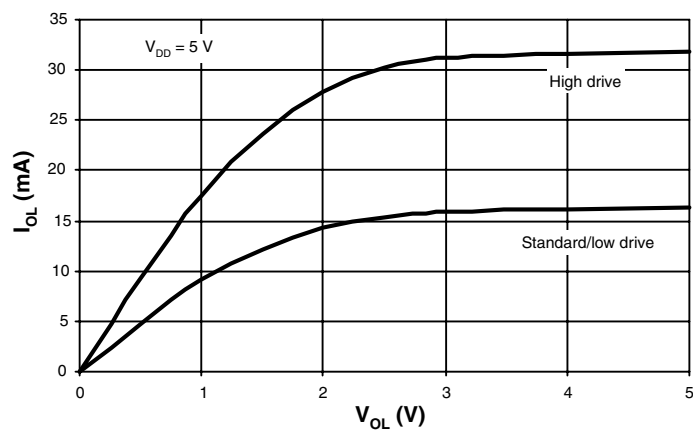
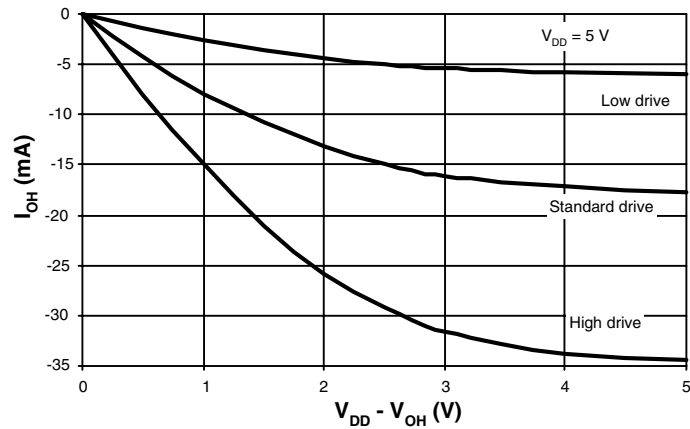

Figure 7-14. Typical High Output Driver Pad Layout, $V_{DD} = 5\text{ V}$



8. PAD Layout

Figure 8-1. Pad Assignments

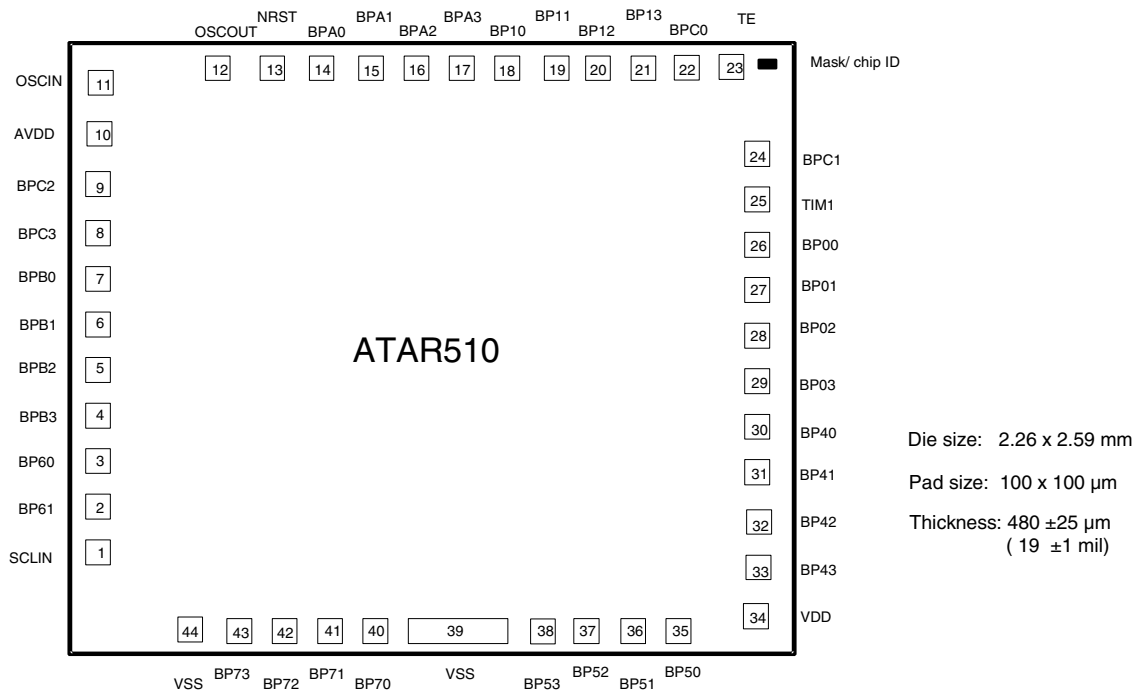

Table 8-1. Pad Coordinates

Pad Number	Name	X-Coordinate	Y-Coordinate
1	SCLIN	113.8	350.55
2	BP61	113.8	500.55
3	BP60	113.8	650.55
4	BPB3	113.8	800.55
5	BPB2	113.8	950.55
6	BPB1	113.8	1100.55
7	BPB0	113.8	1250.55
8	BPC3	113.8	1400.55
9	BPC2	113.8	1550.55
10	AVDD	113.8	1700.55
11	OSCIN	113.8	1850.55
12	OSCOU	501.8	1950.20
13	NRST	651.8	1950.20
14	BPA0	801.8	1950.20
15	BPA1	951.8	1950.20
16	BPA2	1101.8	1950.20
17	BPA3	1251.8	1950.20
18	BP10	1401.8	1950.20
19	BP11	1551.8	1950.20
20	BP12	1701.8	1950.20
21	BP13	1851.8	1950.20
22	BPC0	2001.8	1950.20
23	TE	2151.8	1950.20
24	BPC1	2219.7	1646.10
25	TIM1	2219.7	1496.10
26	BP00	2219.7	1346.10
27	BP01	2219.7	1196.10
28	BP02	2219.7	1046.10
29	BP03	2219.7	896.10
30	BP40	2219.7	746.10
31	BP41	2219.7	596.10
32	BP42	2219.7	446.10
33	BP43	2219.7	296.10
34	VDD	2219.7	146.10
35	BP50	1910.3	144.65
36	BP51	1760.3	144.65
37	BP52	1610.3	144.65
38	BP53	1460.3	144.65
39	VSS	1160.3	144.65
40	BP70	1010.3	144.65
41	BP71	860.3	144.65
42	BP72	710.3	144.65
43	BP73	560.3	144.65
44	VSS	410.3	144.65



9. Application Examples

Figure 9-1. ATAR510 as Keyboard Controller

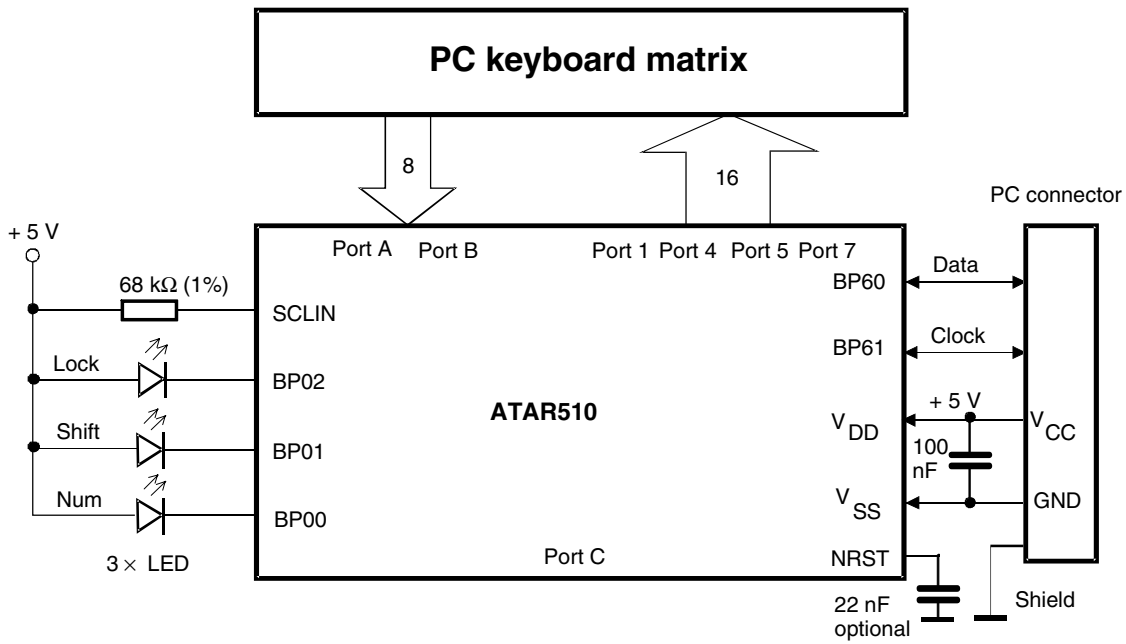
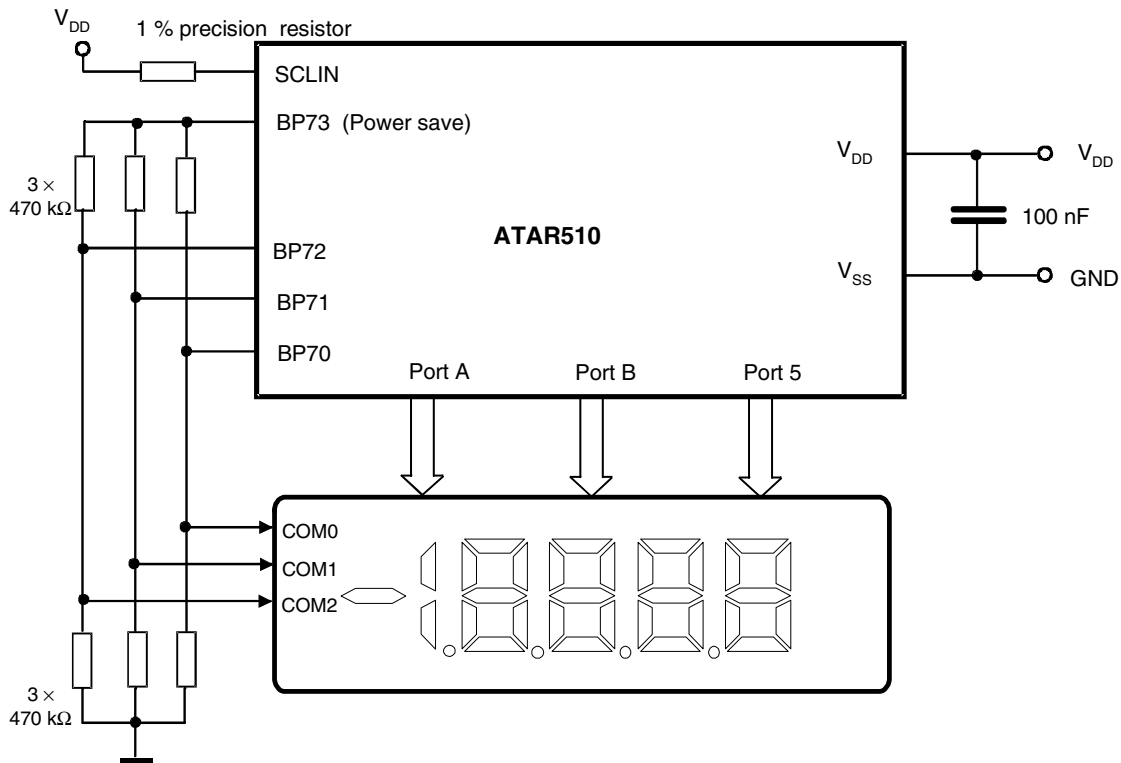

Figure 9-2. Driving a LCD Panel with 1/3 Duty



10. Option Settings for Ordering

Please select the option settings from the list below and insert ROM CRC.

	Output	Input
Port 0		
BP00	<input type="checkbox"/> CMOS	<input type="checkbox"/> Switched pull-up <input type="checkbox"/> Switched pull-down
BP01	<input type="checkbox"/> CMOS	<input type="checkbox"/> Switched pull-up <input type="checkbox"/> Switched pull-down
BP02	<input type="checkbox"/> CMOS	<input type="checkbox"/> Switched pull-up <input type="checkbox"/> Switched pull-down
BP03	<input type="checkbox"/> CMOS	<input type="checkbox"/> Switched pull-up <input type="checkbox"/> Switched pull-down
Port 1		
BP10	<input type="checkbox"/> CMOS	<input type="checkbox"/> Switched pull-up
	<input type="checkbox"/> Open drain [N]	<input type="checkbox"/> Switched pull-down
	<input type="checkbox"/> Open drain [P]	<input type="checkbox"/> Static pull-up <input type="checkbox"/> Static pull-down
BP11	<input type="checkbox"/> CMOS	<input type="checkbox"/> Switched pull-up
	<input type="checkbox"/> Open drain [N]	<input type="checkbox"/> Switched pull-down
	<input type="checkbox"/> Open drain [P]	<input type="checkbox"/> Static pull-up <input type="checkbox"/> Static pull-down
BP12	<input type="checkbox"/> CMOS	<input type="checkbox"/> Switched pull-up
	<input type="checkbox"/> Open drain [N]	<input type="checkbox"/> Switched pull-down
	<input type="checkbox"/> Open drain [P]	<input type="checkbox"/> Static pull-up <input type="checkbox"/> Static pull-down
BP13	<input type="checkbox"/> CMOS	<input type="checkbox"/> Switched pull-up
	<input type="checkbox"/> Open drain [N]	<input type="checkbox"/> Switched pull-down
	<input type="checkbox"/> Open drain [P]	<input type="checkbox"/> Static pull-up <input type="checkbox"/> Static pull-down
Port 4		
BP40	<input type="checkbox"/> CMOS	<input type="checkbox"/> Switched pull-up
	<input type="checkbox"/> Open drain [N]	<input type="checkbox"/> Switched pull-down
	<input type="checkbox"/> Open drain [P]	<input type="checkbox"/> Static pull-up <input type="checkbox"/> Static pull-down
BP41	<input type="checkbox"/> CMOS	<input type="checkbox"/> Switched pull-up
	<input type="checkbox"/> Open drain [N]	<input type="checkbox"/> Switched pull-down
	<input type="checkbox"/> Open drain [P]	<input type="checkbox"/> Static pull-up <input type="checkbox"/> Static pull-down
BP42	<input type="checkbox"/> CMOS	<input type="checkbox"/> Switched pull-up
	<input type="checkbox"/> Open drain [N]	<input type="checkbox"/> Switched pull-down
	<input type="checkbox"/> Open drain [P]	<input type="checkbox"/> Static pull-up <input type="checkbox"/> Static pull-down
BP43	<input type="checkbox"/> CMOS	<input type="checkbox"/> Switched pull-up
	<input type="checkbox"/> Open drain [N]	<input type="checkbox"/> Switched pull-down
	<input type="checkbox"/> Open drain [P]	<input type="checkbox"/> Static pull-up <input type="checkbox"/> Static pull-down

	Output	Input
Port 5		
BP50	<input type="checkbox"/> CMOS	<input type="checkbox"/> Switched pull-up
	<input type="checkbox"/> Open drain [N]	<input type="checkbox"/> Switched pull-down
	<input type="checkbox"/> Open drain [P]	<input type="checkbox"/> Static pull-up <input type="checkbox"/> Static pull-down
BP51	<input type="checkbox"/> CMOS	<input type="checkbox"/> Switched pull-up
	<input type="checkbox"/> Open drain [N]	<input type="checkbox"/> Switched pull-down
	<input type="checkbox"/> Open drain [P]	<input type="checkbox"/> Static pull-up <input type="checkbox"/> Static pull-down
BP52	<input type="checkbox"/> CMOS	<input type="checkbox"/> Switched pull-up
	<input type="checkbox"/> Open drain [N]	<input type="checkbox"/> Switched pull-down
	<input type="checkbox"/> Open drain [P]	<input type="checkbox"/> Static pull-up <input type="checkbox"/> Static pull-down
BP53	<input type="checkbox"/> CMOS	<input type="checkbox"/> Switched pull-up
	<input type="checkbox"/> Open drain [N]	<input type="checkbox"/> Switched pull-down
	<input type="checkbox"/> Open drain [P]	<input type="checkbox"/> Static pull-up <input type="checkbox"/> Static pull-down
Port 6		
BP60	<input type="checkbox"/> CMOS	<input type="checkbox"/> Switched pull-up
	<input type="checkbox"/> Open drain [N]	<input type="checkbox"/> Switched pull-down
	<input type="checkbox"/> Open drain [P]	<input type="checkbox"/> Static pull-up <input type="checkbox"/> Static pull-down
BP61	<input type="checkbox"/> CMOS	<input type="checkbox"/> Switched pull-up
	<input type="checkbox"/> Open drain [N]	<input type="checkbox"/> Switched pull-down
	<input type="checkbox"/> Open drain [P]	<input type="checkbox"/> Static pull-up <input type="checkbox"/> Static pull-down
Port 7		
BP70	<input type="checkbox"/> CMOS	<input type="checkbox"/> Switched pull-up
	<input type="checkbox"/> Open drain [N]	<input type="checkbox"/> Switched pull-down
	<input type="checkbox"/> Open drain [P]	<input type="checkbox"/> Static pull-up <input type="checkbox"/> Static pull-down
BP71	<input type="checkbox"/> CMOS	<input type="checkbox"/> Switched pull-up
	<input type="checkbox"/> Open drain [N]	<input type="checkbox"/> Switched pull-down
	<input type="checkbox"/> Open drain [P]	<input type="checkbox"/> Static pull-up <input type="checkbox"/> Static pull-down
BP72	<input type="checkbox"/> CMOS	<input type="checkbox"/> Switched pull-up
	<input type="checkbox"/> Open drain [N]	<input type="checkbox"/> Switched pull-down
	<input type="checkbox"/> Open drain [P]	<input type="checkbox"/> Static pull-up <input type="checkbox"/> Static pull-down
BP73	<input type="checkbox"/> CMOS	<input type="checkbox"/> Switched pull-up
	<input type="checkbox"/> Open drain [N]	<input type="checkbox"/> Switched pull-down
	<input type="checkbox"/> Open drain [P]	<input type="checkbox"/> Static pull-up <input type="checkbox"/> Static pull-down

10. Option Settings for Ordering (Continued)

Please select the option settings from the list below and insert ROM CRC.

	Output	Input
Port A		
BPA0	<input type="checkbox"/> CMOS	<input type="checkbox"/> Switched pull-up
	<input type="checkbox"/> Open drain [N]	<input type="checkbox"/> Switched pull-down
	<input type="checkbox"/> Open drain [P]	<input type="checkbox"/> Static pull-up
BPA1	<input type="checkbox"/> CMOS	<input type="checkbox"/> Switched pull-up
	<input type="checkbox"/> Open drain [N]	<input type="checkbox"/> Switched pull-down
	<input type="checkbox"/> Open drain [P]	<input type="checkbox"/> Static pull-up
BPA2	<input type="checkbox"/> CMOS	<input type="checkbox"/> Switched pull-up
	<input type="checkbox"/> Open drain [N]	<input type="checkbox"/> Switched pull-down
	<input type="checkbox"/> Open drain [P]	<input type="checkbox"/> Static pull-up
BPA3	<input type="checkbox"/> CMOS	<input type="checkbox"/> Switched pull-up
	<input type="checkbox"/> Open drain [N]	<input type="checkbox"/> Switched pull-down
	<input type="checkbox"/> Open drain [P]	<input type="checkbox"/> Static pull-up
Port B		
BPB0	<input type="checkbox"/> CMOS	<input type="checkbox"/> Switched pull-up
	<input type="checkbox"/> Open drain [N]	<input type="checkbox"/> Switched pull-down
	<input type="checkbox"/> Open drain [P]	<input type="checkbox"/> Static pull-up
BPB1	<input type="checkbox"/> CMOS	<input type="checkbox"/> Switched pull-up
	<input type="checkbox"/> Open drain [N]	<input type="checkbox"/> Switched pull-down
	<input type="checkbox"/> Open drain [P]	<input type="checkbox"/> Static pull-up
BPB2	<input type="checkbox"/> CMOS	<input type="checkbox"/> Switched pull-up
	<input type="checkbox"/> Open drain [N]	<input type="checkbox"/> Switched pull-down
	<input type="checkbox"/> Open drain [P]	<input type="checkbox"/> Static pull-up
BPB3	<input type="checkbox"/> CMOS	<input type="checkbox"/> Switched pull-up
	<input type="checkbox"/> Open drain [N]	<input type="checkbox"/> Switched pull-down
	<input type="checkbox"/> Open drain [P]	<input type="checkbox"/> Static pull-up
TIM1		
BPB0	<input type="checkbox"/> CMOS	<input type="checkbox"/> Switched pull-up
	<input type="checkbox"/> Open drain [N]	<input type="checkbox"/> Switched pull-down
	<input type="checkbox"/> Open drain [P]	<input type="checkbox"/> Static pull-up

	Output	Input
Port C		
BPC0	<input type="checkbox"/> CMOS	<input type="checkbox"/> Switched pull-up
	<input type="checkbox"/> Open drain [N]	<input type="checkbox"/> Switched pull-down
	<input type="checkbox"/> Open drain [P]	<input type="checkbox"/> Static pull-up
BPC1	<input type="checkbox"/> CMOS	<input type="checkbox"/> Switched pull-up
	<input type="checkbox"/> Open drain [N]	<input type="checkbox"/> Switched pull-down
	<input type="checkbox"/> Open drain [P]	<input type="checkbox"/> Static pull-up
BPC2	<input type="checkbox"/> CMOS	<input type="checkbox"/> Switched pull-up
	<input type="checkbox"/> Open drain [N]	<input type="checkbox"/> Switched pull-down
	<input type="checkbox"/> Open drain [P]	<input type="checkbox"/> Static pull-up
BPC3	<input type="checkbox"/> CMOS	<input type="checkbox"/> Switched pull-up
	<input type="checkbox"/> Open drain [N]	<input type="checkbox"/> Switched pull-down
	<input type="checkbox"/> Open drain [P]	<input type="checkbox"/> Static pull-up
BPA-reset	<input type="checkbox"/> No <input type="checkbox"/> BPA0 and BPA1 = low <input type="checkbox"/> BPA0 and BPA1 and BPA2 = low <input type="checkbox"/> BPA0 and BPA1 and BPA2 and BPA3 = low <input type="checkbox"/> BPA0 and BPA1 = high <input type="checkbox"/> BPA0 and BPA1 and BPA2 = high <input type="checkbox"/> BBPA0 and BPA1 and BPA2 and BPA3 = high	
Watchdog	<input type="checkbox"/> 0.5 s <input type="checkbox"/> 1 s <input type="checkbox"/> 2 s	<input type="checkbox"/> Disabled
OSCIN	<input type="checkbox"/> No integrated capacitance <input type="checkbox"/> Internal CAP (_pF)	
OSCOU	<input type="checkbox"/> No integrated capacitance <input type="checkbox"/> Internal CAP (_pF)	
Package	<input type="checkbox"/> DIT <input type="checkbox"/> DOW <input type="checkbox"/> SSO44	

Please attach this page to the approval form.

Date: _____ Signature: _____ Company: _____

11. Ordering Information

Extended Type Number	Program Memory	Data-EEPROM	Package	Delivery
ATAR510x-yyy-ILQY	4 kB ROM	No	SSO44	Taped and reeled
ATAR510x-yyy-ILSY	4 kB ROM	No	SSO44	Tubes

Note: 1. x = Hardware revision
 yyy = Customer specific ROM-version
 Y = Lead-free

12. Package Information

Package SSO44

Dimensions in mm

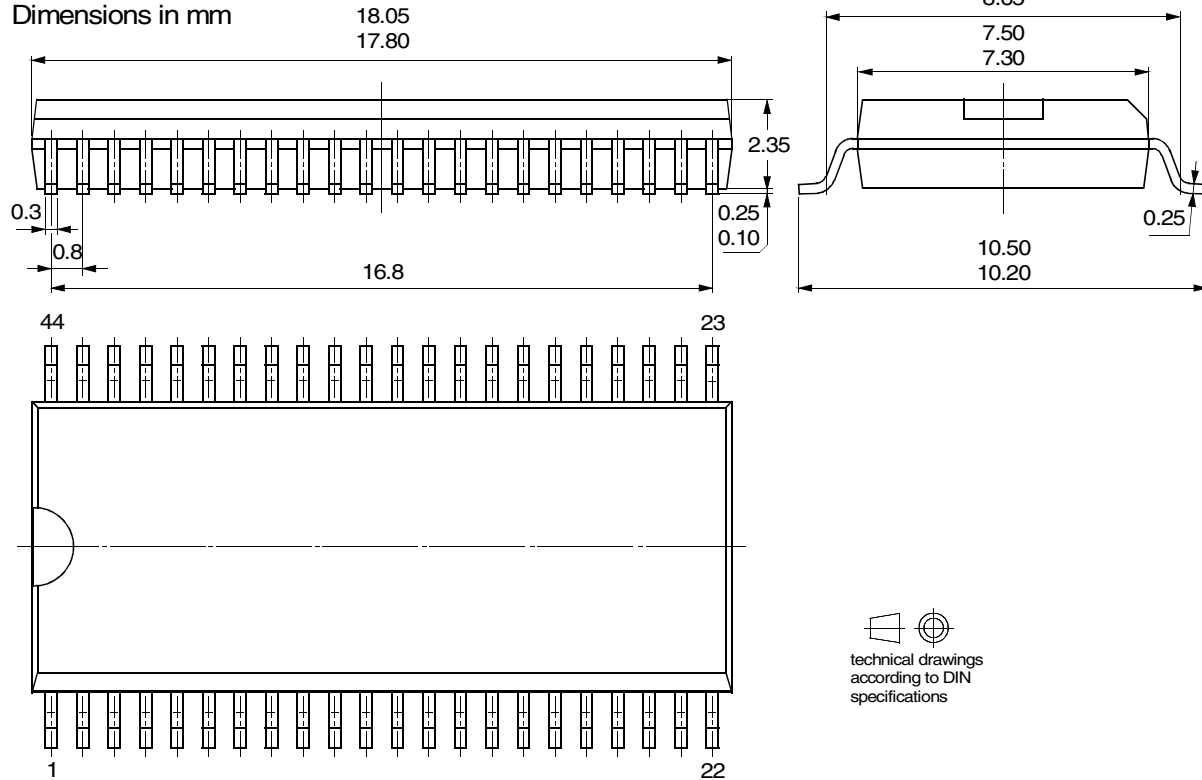

 technical drawings
 according to DIN
 specifications

13. Revision History

Please note that the following page numbers referred to in this section refer to the specific revision mentioned, not to this document.

Revision No.	History
4703B-4BMCU-01/05	<ul style="list-style-type: none"> • Put datasheet in a new template. • Features on page 1 changed. • Lead-free Logo on page 1 added. • Table 1-1 “Pin Description” on pages 3-4 changed. • Figure 2-4 “Programming Model” on page 8 changed. • Section 2.3.1 “Interrupt Processing” on page 10 changed. • Section 2.5.2.5 “32-kHz Oscillator” on page 17 changed. • Title Table 2-6 on page 18 added. • Table 3-1 “Peripheral Addresses” on page 22 changed. • New heading rows at Table “Absolute Maximum Ratings” on page 58 added. • Table name on page 69 and 70 changed. • Table “Ordering Information” on page 71 added.

14. Table of Contents

Features 1

Description 1

1 Pin Configuration 3

2 MARC4 Architecture 5

 2.1 General Description5

 2.2 Components of MARC4 Core6

 2.3 Interrupt Structure 10

 2.4 Master Reset 12

 2.5 Clock Generation 14

3 Peripheral Modules 20

 3.1 Addressing Peripherals20

 3.2 Bi-directional Ports23

 3.3 Interval Timers/Prescaler31

 3.4 Watchdog Timer34

 3.5 Timer/Counter Module (TCM)34

 3.6 Buzzer Module54

 3.7 Emulation56

 3.8 MTP Support56

 3.9 Noise Considerations57

4 Absolute Maximum Ratings 58

5 DC Operating Characteristics 58

6 AC Characteristics 60

7 Crystal Characteristics 61

8 PAD Layout 66

9 Application Examples 68

10 Option Settings for Ordering 69

11 Ordering Information 71

12 Package Information 71

13 Revision History 72



Atmel Corporation

2325 Orchard Parkway
San Jose, CA 95131, USA
Tel: 1(408) 441-0311
Fax: 1(408) 487-2600

Regional Headquarters

Europe

Atmel Sarl
Route des Arsenaux 41
Case Postale 80
CH-1705 Fribourg
Switzerland
Tel: (41) 26-426-5555
Fax: (41) 26-426-5500

Asia

Room 1219
Chinachem Golden Plaza
77 Mody Road Tsimshatsui
East Kowloon
Hong Kong
Tel: (852) 2721-9778
Fax: (852) 2722-1369

Japan

9F, Tonetsu Shinkawa Bldg.
1-24-8 Shinkawa
Chuo-ku, Tokyo 104-0033
Japan
Tel: (81) 3-3523-3551
Fax: (81) 3-3523-7581

Atmel Operations

Memory

2325 Orchard Parkway
San Jose, CA 95131, USA
Tel: 1(408) 441-0311
Fax: 1(408) 436-4314

Microcontrollers

2325 Orchard Parkway
San Jose, CA 95131, USA
Tel: 1(408) 441-0311
Fax: 1(408) 436-4314

La Chantrerie
BP 70602
44306 Nantes Cedex 3, France
Tel: (33) 2-40-18-18-18
Fax: (33) 2-40-18-19-60

ASIC/ASSP/Smart Cards

Zone Industrielle
13106 Rousset Cedex, France
Tel: (33) 4-42-53-60-00
Fax: (33) 4-42-53-60-01

1150 East Cheyenne Mtn. Blvd.
Colorado Springs, CO 80906, USA
Tel: 1(719) 576-3300
Fax: 1(719) 540-1759

Scottish Enterprise Technology Park
Maxwell Building
East Kilbride G75 0QR, Scotland
Tel: (44) 1355-803-000
Fax: (44) 1355-242-743

RF/Automotive

Theresienstrasse 2
Postfach 3535
74025 Heilbronn, Germany
Tel: (49) 71-31-67-0
Fax: (49) 71-31-67-2340

1150 East Cheyenne Mtn. Blvd.
Colorado Springs, CO 80906, USA
Tel: 1(719) 576-3300
Fax: 1(719) 540-1759

Biometrics/Imaging/Hi-Rel MPU/ High Speed Converters/RF Datacom

Avenue de Rochepleine
BP 123
38521 Saint-Egreve Cedex, France
Tel: (33) 4-76-58-30-00
Fax: (33) 4-76-58-34-80

Literature Requests

www.atmel.com/literature

Disclaimer: The information in this document is provided in connection with Atmel products. No license, express or implied, by estoppel or otherwise, to any intellectual property right is granted by this document or in connection with the sale of Atmel products. **EXCEPT AS SET FORTH IN ATMEL'S TERMS AND CONDITIONS OF SALE LOCATED ON ATMEL'S WEB SITE, ATMEL ASSUMES NO LIABILITY WHATSOEVER AND DISCLAIMS ANY EXPRESS, IMPLIED OR STATUTORY WARRANTY RELATING TO ITS PRODUCTS INCLUDING, BUT NOT LIMITED TO, THE IMPLIED WARRANTY OF MERCHANTABILITY, FITNESS FOR A PARTICULAR PURPOSE, OR NON-INFRINGEMENT. IN NO EVENT SHALL ATMEL BE LIABLE FOR ANY DIRECT, INDIRECT, CONSEQUENTIAL, PUNITIVE, SPECIAL OR INCIDENTAL DAMAGES (INCLUDING, WITHOUT LIMITATION, DAMAGES FOR LOSS OF PROFITS, BUSINESS INTERRUPTION, OR LOSS OF INFORMATION) ARISING OUT OF THE USE OR INABILITY TO USE THIS DOCUMENT, EVEN IF ATMEL HAS BEEN ADVISED OF THE POSSIBILITY OF SUCH DAMAGES.** Atmel makes no representations or warranties with respect to the accuracy or completeness of the contents of this document and reserves the right to make changes to specifications and product descriptions at any time without notice. Atmel does not make any commitment to update the information contained herein. Atmel's products are not intended, authorized, or warranted for use as components in applications intended to support or sustain life.

© Atmel Corporation 2005. All rights reserved. Atmel®, logo and combinations thereof, and others, are registered trademarks, and Every-where You AreSM and others are the trademarks of Atmel Corporation or its subsidiaries. Windows®, Windows NT®, and others are registered trademarks of Microsoft Corporation. Other terms and product names may be trademarks of others.



Printed on recycled paper.

4703B-4BMCU-01/05