

1.0 General Description

The AMIS-710627-A4 (PI627MC-A4), AMIS-710628-A4 (PI628MC-A4) and AMIS-710629-A4 (PI629MC-A4) are a family of contact image sensor (CIS) modules, using MOS image sensor technology for high-speed performance and high sensitivity. They contain a complete optical imaging system that includes the light source and focusing elements.

The modules' contact image sensor is divided into four sections, each with its own video output and identical processing circuits allowing for high scanning speeds. Each module comes with its own particular LED light source, which have different maximum light power outputs. Since the light power limits the exposure, which is proportional to the product of scanning speed and light power, each module will have a different maximum scanning speed and signal output voltage.

The modules can be used for scanning A4 size (216mm) documents with 23.62 dots per millimeter (dpm) resolution. Applications include document scanning, mark readers, gaming, and office automation equipment.

2.0 Key Features

- LED light source, lens and sensor are integrated into a single module
- Ultra high-speed
- Four parallel analog video outputs, clocked as high as 5.5MHz
- 270 μ sec/line scanning speed @ 5.0MHz clock rate for the red light source
- 23.62dots/mm resolution, 216mm scanning length
- Wide dynamic range
- Standard A4 size \cong 14.5mm x 19.5mm x 232mm
- Low power
- Light weight

3.0 Functional Description

Each of the three modules consists of 27 AMIS-720639 (PI3039) image sensors cascaded together. Each sensor consists of 192 photo-sensing elements (pixels), resulting in a module 5184 pixels long.

These image sensors have associated multiplex switches that are sequentially accessed with its digital shift register. In addition, each has a chip-select switch that functions to activate its preceding sensor on the cascaded sequence, after its predecessor chip has completed its scan. The start pulse initiates the shift register of the first chip in all four sections. The first chip then sequentially clocks out the integrated image charge from each pixel. These charges are passed through the sensors' multiplexing switch and then out onto the video line, where they are converted to a voltage. When the sensor completes its scan, the chip-select switch on the following chip is switched on to continue the line scan until it completes its scan in one section. A new scan is initiated when a start pulse is again entered into the first chip of each section.

The 27 sensors are cascaded together and bonded onto a PCB. The cascaded sensors are then divided into four subsections, each subsection having its own output. The first three subsections contain seven sensors and the fourth contains six sensors. Each output is then connected to its own video line. The four video lines form a video line capacitance, which are buffered by video amplifiers, to act as output drivers. The charge from each output is integrated onto the video line capacitance and readout. Each pixel is then reset and ready to integrate again.

Mounted in the module is a one-to-one graded indexed micro lens array that focuses the scanned documents to be imaged onto its sensing plane.

Illumination is by means of an integrated LED light source. The particular LED for each module is listed in Table 1.

Table 1: Module vs. LED Light Source

Module	LED Type
AMIS-710627-A4	660nm Red LED bar
AMIS-710628-A4	525nm Green LED bar
AMIS-710629-A4	Low-power Yellow-Green LED bar

All components are housed in a small plastic housing which has a glass cover that acts as the focal point for the object being scanned and protects the imaging array, micro lens assembly, and LED light source from dust.

Figures 1 and 2 show a block diagram and a cross section of a module.

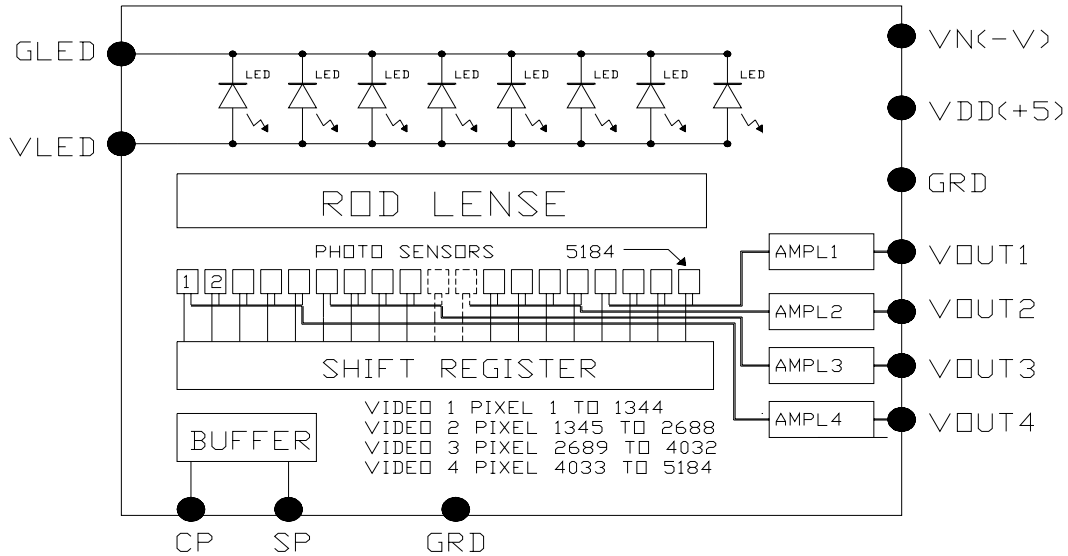

Figure 1: Module Block Diagram

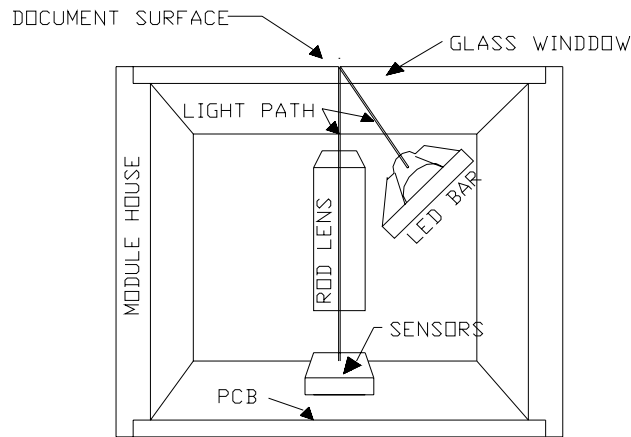

Figure 2: Module Cross Section

4.0 Connector Pin Out

Inputs and outputs to the module are via a 12-pin connector, part number JAE IL-Z-12P-S125L3-E, located on one end of the module.

Table 2 lists the connector pin-out with their symbols and descriptions.

Table 2: Pin Out Configuration

Connector Pin Number	Symbol	Description
1	VOUT1	Analog video output 1
2	VOUT2	Analog video output 2
3	GND	Ground
4	VOUT3	Analog video output 3
5	VOUT4	Analog video output 4
6	Vdd	Power supply
7	SP(START)	Shift register start pulse
8	GND	Ground
9	CP(CLOCK)	Clock pulse
10	Vn	Negative power supply
11	GLED	Ground for the light source
12	VLED	Power supply for the light source

5.0 Absolute Maximum Rating

Table 3 shows the absolute maximum ratings for the parameters common to all three modules. As each module has its own particular LED source, Table 4 shows the absolute maximum ratings particular to each of the three LED light sources. These are the absolute maximum ratings and continuous operation is not recommended.

Table 3: Absolute Maximum Ratings Common to all Three Modules

Parameter	Symbol	Max. Rating	Units
Power supply	Vdd	7	V
	Idd	100	mA
	Vn	-15	V
	In	20	mA
Input clock pulse (high level)	Vih	Vdd - 0.5V	V
Input clock pulse (low level)	Vil	-0.5	V

Table 4: LED Absolute Maximum Ratings

Parameter	Max. Rating			Units
	AMIS-710627-A4 / 660nm Red LED	AMIS-710628-A4 / 525nm Green LED	AMIS-710629-A4 / Low-power Yellow-Green LED	
VLED	5.5	5.5	5.5	V
ILED	0.7	1.0	1.0	A

6.0 Environmental Specifications

Table 5 lists the environmental conditions for the modules.

Table 5: Operating and Storage Environment

Parameter	Max. Rating	Units
Operating temperature	0 to 50	°C
Operating humidity	10 to 90	%
Storage temperature	-20 to+75	°C
Storage humidity	10 to 90	%

7.0 Electro-Optical Characteristics at 25°C

Table 6 lists the electro-optical characteristics common to all three modules. Tables 7, 8 and 9 show the characteristics particular to each of the three LED light sources.

Table 6: Electro-Optical Characteristics Common to all Three Modules

Parameter	Value	Units
Total number of pixels in each module	5184	Elements
Number of pixels in Sections 1, 2 & 3	1344	Elements
Number of pixels in Section 4	1152	Elements
Pixel-to-pixel spacing	42.3	µm

Module: AMIS-710627-A4
Light source: 660nm Red LED

Table 7: AMIS-710627-A4 / 660nm Red LED Electro-Optical Characteristics

Parameter	Symbol	Value	Units	Note
Line scanning rate ⁽¹⁾	Tint	450	µsec	@ 3.0MHz clock frequency
Clock frequency ⁽²⁾	Fclk	3.0	MHz	
Bright output voltage ⁽³⁾⁽⁷⁾	Video output	0.5	Volt	
Bright output non-uniformity ⁽⁴⁾	Up	< +/-30	%	
Adjacent photo-response non-uniformity ⁽⁵⁾	Upn	<25	%	
Dark non-uniformity ⁽⁶⁾	Ud	< 100	mV	
Dark output voltage ⁽⁷⁾	Dark level (DL)	< 350	mV	
Modulation transfer function ⁽⁸⁾	MTF	> 40	%	

Module: AMIS-710628-A4
Light source: 525nm Green LED

Table 8: AMIS-710628-A4 / 525nm Green LED Electro-Optical Characteristics

Parameter	Symbol	Value	Units	Note
Line scanning rate ⁽¹⁾	Tint	270	μsec	@ 5.0MHz clock frequency
Clock frequency ⁽²⁾	Fclk	5.0	MHz	
Bright output voltage ⁽³⁾⁽⁷⁾	Video Output	0.5	Volt	
Bright output non-uniformity ⁽⁴⁾	Up	< +/-30	%	
Adjacent photo-response non-uniformity ⁽⁵⁾	Upn	<25	%	
Dark non-uniformity ⁽⁶⁾	Ud	< 100	mV	
Dark output voltage ⁽⁷⁾	Dark Level (DL)	< 350	mV	
Modulation transfer function ⁽⁸⁾	MTF	> 40	%	

Module: AMIS-710629-A4
Light source: Low-power Yellow-Green LED

Table 9: AMIS-710629-A4 / Low-power Yellow-Green LED Electro-Optical Characteristics

Parameter	Symbol	Value	Units	Notes
Line scanning rate ⁽¹⁾	Tint	450	μsec	@ 3.0MHz clock frequency
Clock frequency ⁽²⁾	Fclk	3.0	MHz	
Bright output voltage ⁽³⁾⁽⁷⁾	Video Output	0.5	Volt	
Bright output non-uniformity ⁽⁴⁾	Up	< +/-30	%	
Adjacent photo-response non-uniformity ⁽⁵⁾	Upn	<25	%	
Dark non-uniformity ⁽⁶⁾	Ud	< 100	mV	
Dark output voltage ⁽⁷⁾	Dark Level (DL)	< 350	mV	
Modulation transfer function ⁽⁸⁾	MTF	> 40	%	

- Notes:**
- Tint is the line-scanning rate or integration time and is determined by the interval between two start pulses, SP. The integration time listed for each module is the minimum integration time required to give 0.5V output at each modules maximum clock frequency.
 - Fclk is the main clock frequency, also equals the pixel rate.
 - Video output level is dependent on the integration time and LED light power.
 - $Up = [Vp(max) - Vpavg] / Vpavg \times 100\%$ or $[Vpavg - Vp(min)] / Vpavg \times 100\%$, whichever is greater, where $Vp(max)$ = maximum pixel level, $Vp(min)$ = minimum pixel level, and $Vpavg$ = average of all pixels.
 - Adjacent photo-response non-uniformity (Upn).
 $Upn = \text{Max} ((Vpn - Vpn+1) / \text{Min} (Vpn, Vpn+1)) \times 100\%$, where Vpn is the pixel output voltage of pixel n in the light.
 - $Ud = Vdmax - Vdmin$, where $Vdmin$ is the minimum output voltage with LED off and $Vdmax$ is maximum output voltage with LED on.
 - See the paragraph under Reset Level and Video Sampling Time for explanation.
 - See the paragraph under Depth of Focus. A graph of the typical MTF vs. Depth of Focus is shown.

8.0 Recommended Operating Conditions at 25°C

Table 10 lists the recommended operating conditions common to all three modules. Table 11 lists the recommended operating conditions particular to each of the three LED light sources.

Table 10: Recommended Operating Conditions at 25°C, Common to all Three Modules

Parameter	Symbol	Min.	Typ.	Max.	Units
Power supply	Vdd (positive)	4.5	5.0	5.5	V
	Vn (negative)	-10	-5	-4.0	V
	Idd (positive)	60	66	75	mA
	In (negative)	19	20	21	mA
Input voltage (high level)	Vih	Vdd - 1.0	Vdd - 0.5	Vdd	V
Input voltage (low level)	Vil	0		0.6	V
Clock frequency ⁽¹⁾	Fclk	0.518		5.5	MHz
Clock pulse high duty cycle	Duty	25	50	75	%
Clock pulse high duration	Pwck	46			ns
Integration time ⁽¹⁾	Tint	82	150		μs
Operating temperature	Top		25	50	C

Table 11: Recommended Operating Conditions at 25°C, for each LED

LED Light Source	Parameter	Min.	Typ.	Max.	Units
660nm Red LED	VLED		5.0	5.5	Volts
	ILED		480	550	mA
525nm Green LED	VLED		5.0	5.5	Volts
	ILED		TBD	TBD	mA
Low-power Yellow-Green LED	VLED		5.0	5.5	Volts
	ILED		TBD	TBD	mA

- Note:**
- The maximum clock speed is limited by the modules light source power, due to the low light power associated with LED's. The minimum clock speed is determined by the longest tolerable integration time. Because of the leakage current build up, the integration time is recommended to be no greater than 10ms.

9.0 Reset Level and Video Sampling Time

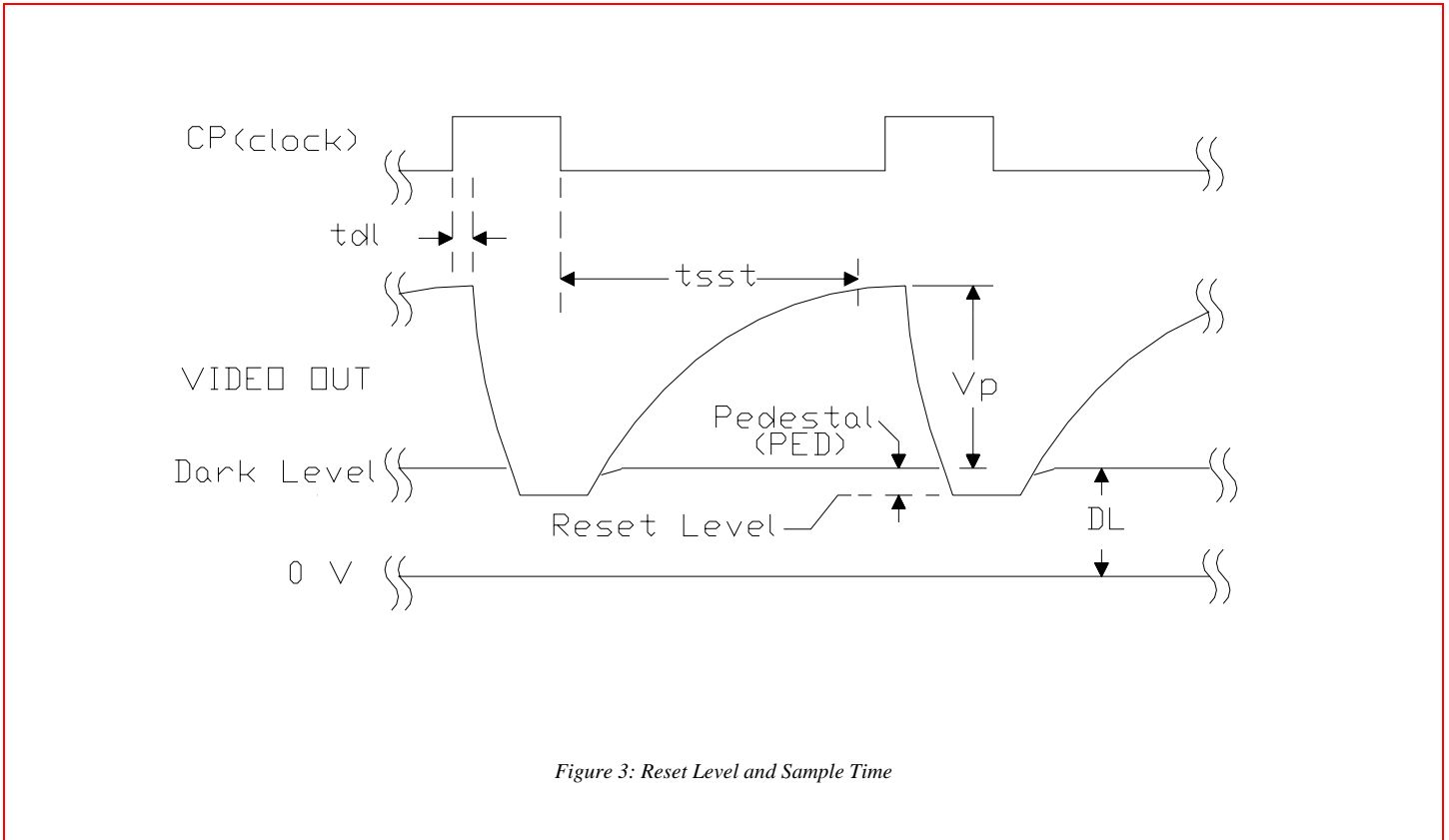

Figure 3: Reset Level and Sample Time

Figure 3 shows the video signal waveform and details a single pixel. The signal output waveform is shown referenced to the input clock waveform. Also shown is the terminology used to define the dark and bright output levels and the recommended pixels sampling times.

The dark level is defined by using the module imaging on a black target or with the light source turned off. The dark level is then measured from ground or 0V. The reset level is a reference level of the reset switch, which is not necessarily at ground. The reason for this is that after the reset operation, the video signal is passed through an amplifier, which may have some offsets. The difference between the dark level and reset level is called the pedestal, PED. Hence, the reset level will sit below the dark level.

The video pixels, demonstrated in this graph, are ideal waveforms from a CIS module using a phototransistor imaging structure. The video output at high speeds, such as 5.0MHz, does not instantly rise to its final value, although, if it is given enough time it would eventually approach its steady state value (in order of milliseconds). However, at high speeds it is impractical to wait until a final stable value is reached. The suggested sampling point is therefore a few nanoseconds prior to the signal falling edge.

10.0 Depth of Focus

Figure 4 shows the typical MTF versus Distance, which can be used to define the working depth of focus. Two curves indicate the spread among the modules. Note that the MTF is greater than 40 percent out to a distance greater than 0.3mm from the glass surface. Since this module is a 600dpi module, a pixel density of 600 pixels per inch, the MTF was measured with a 300dpi or a 150 line-pair per inch optical bar pattern. The test was conducted with pixel rate set to 5.0MHz.

The effective algorithm used in the measurements is as described by the following equation:

$$MTF = \frac{[Vp(n)+Vp(n+1)]/2 - [Vp(n+2)+Vp(n+3)]/2}{\{[Vp(n)+Vp(n+1)]/2 + [Vp(n+2)+Vp(n+3)]/2\}}$$

Where n is 1, 2,5184th, Vp(n) is the signal amplitude of the nth pixel.

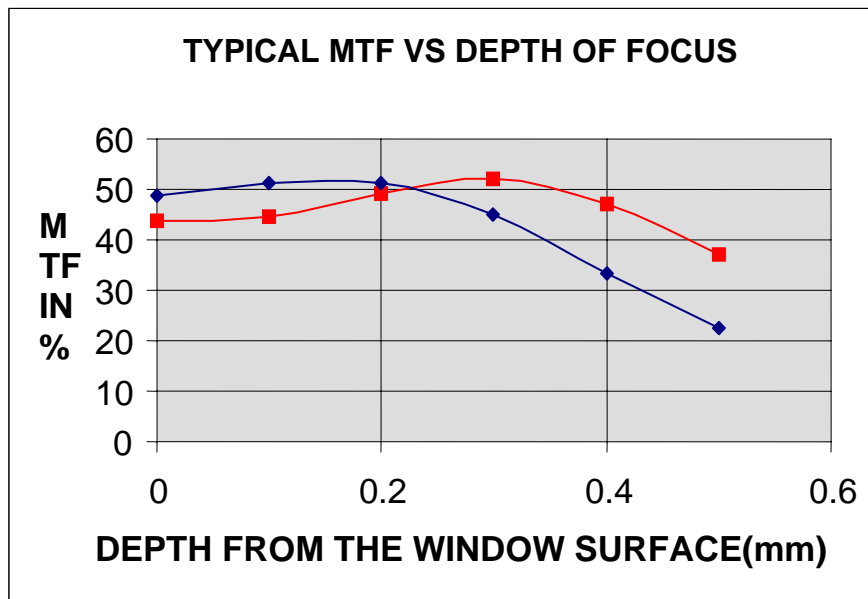

11.0 Timing Characteristics at 25°C

The timing characteristics at 25°C for the I/O clocks are shown in Figure 5 and their definitions detailed in Table 12. Only one video output is shown because all four video sections have identical electrical characteristics. Since there are seven die in sections one, two and three and six die in Section 4, the output waveform for Section 4 (Vout 4) is shorter by 192 pixels.

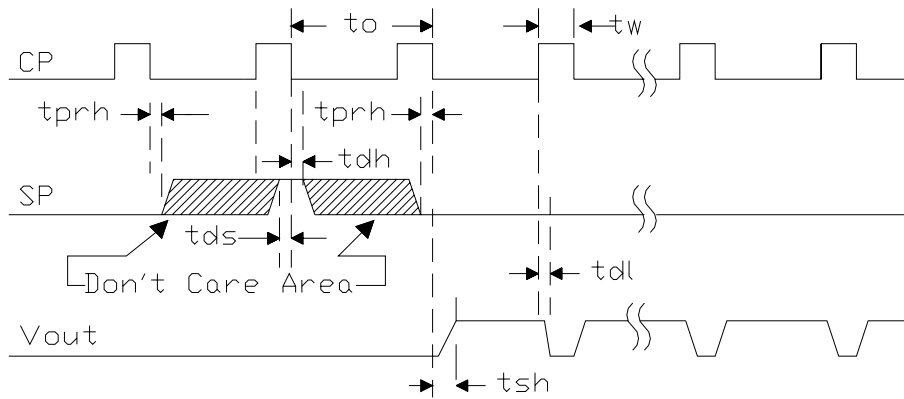

Figure 5: Module Timing Diagram

Table 12: Timing Definitions

Item	Symbol	Min.	Typ.	Max.	Units
Clock cycle time	to	0.182		1.93	μs
Clock pulse width	tw	46		1448	ns
Clock duty cycle		25		75	%
Prohibit crossing time of the SP ⁽¹⁾	tprh	50			ns
Data setup time	tds	50			ns
Data hold time	tdh	50			ns
Signal delay time	tdl	50			ns
Signal settling time	tsh	100			ns

Note:

1. "Prohibit crossing of the start pulse", tprh, is to indicate that the start pulse should not be active high between two consecutive low going clock pulses. All falling clock edges under an active high start pulse loads the internal shift register, therefore the start pulse must be active over only one falling clock edge. A high start pulse crossing over any rising clock edges are ignored by the shift register. One simple way to ensure that the start pulse will not be actively high for any two consecutive falling clock edges is to generate the start pulse on a rising clock edge and terminate it on the following rising clock edge.

12.0 Mechanical Structure of the Module

Figure 6 is an overview of the module housing showing the connector location; the module's approximate overall dimensions and its general layout. It is not intended for use as a design reference. A detailed drawing for any of the AMIS-710627-A4 / AMIS-710628-A4 / AMIS-710629-A4 module housings is available upon request.

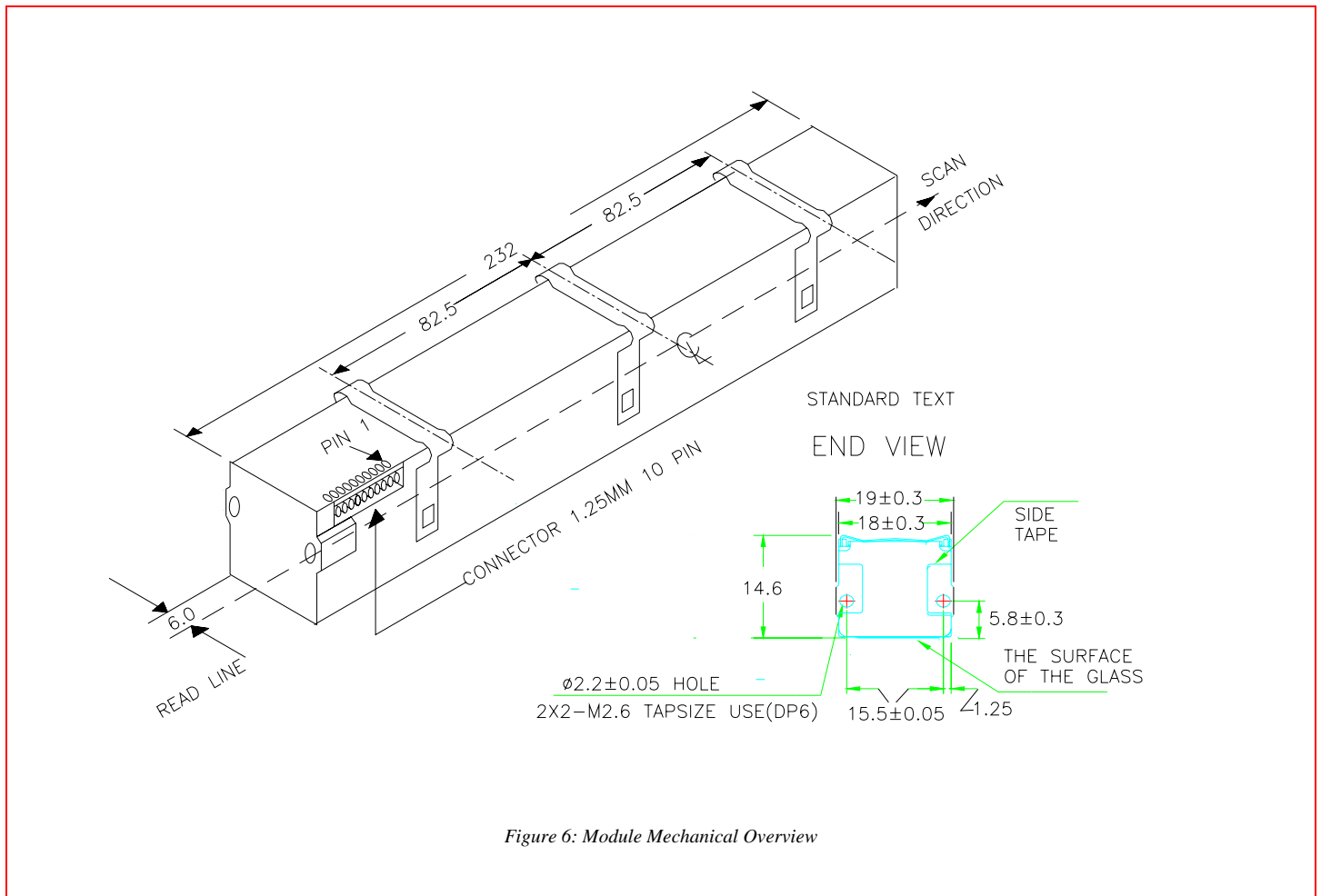

Figure 6: Module Mechanical Overview

13.0 Company or Product Inquiries

For more information about AMI Semiconductor's image sensors, please send an email to image_sensors@amis.com.

For more information about AMI Semiconductor's products or services visit our Web site at <http://www.amis.com>.

Production Technical Data - The information contained in this document applies to a product in production. AMI Semiconductor and its subsidiaries ("AMIS") have made every effort to ensure that the information is accurate and reliable. However, the characteristics and specifications of the product are subject to change without notice and the information is provided "AS IS" without warranty of any kind (express or implied). Customers are advised to obtain the latest version of relevant information to verify that data being relied on is the most current and complete. AMIS reserves the right to discontinue production and change specifications and prices at any time and without notice. Products sold by AMIS are covered by the warranty and patent indemnification provisions appearing in its Terms of Sale only. AMIS makes no other warranty, express or implied, and disclaims the warranties of noninfringement, merchantability, or fitness for a particular purpose. AMI Semiconductor's products are intended for use in ordinary commercial applications. These products are not designed, authorized, or warranted to be suitable for use in life-support systems or other critical applications where malfunction may cause personal injury. Inclusion of AMIS products in such applications is understood to be fully at the customer's risk. Applications requiring extended temperature range, operation in unusual environmental conditions, or high reliability, such as military or medical life-support, are specifically not recommended without additional processing by AMIS for such applications. Copyright © 2006 AMI Semiconductor, Inc.