



Ag1110

LOW COST SLIC

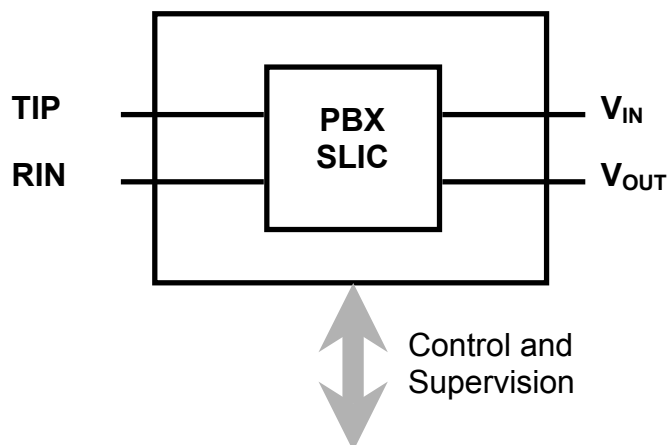

Figure 1: Single Channel SLIC

DESCRIPTION

The Silver Telecom Ag1110 comprises a single Subscriber Line Interface Circuit (SLIC) in a single-in-line (SIL) 13 pin format. The combination of features and packaging offers extremely efficient use of board area, saving significant system size and cost.

The SLIC is highly featured requiring a minimum of external components. Functions such as a relay driver, are provided on board along with precision loop feed resistors.

FEATURES

- Single-in-line (SIL) PBX SLIC with integral lead frame.
- Highly integrated, requiring a minimum of external components.
- Constant current feed to the line, with constant voltage fold over.
- Single +5V system side power supply.
- 16mA minimum loop current into 2000R loop (including telephone set).
- 600R and 900R impedance options.
- Works with a battery of up to -72V.
- Low idle power operation (20mW).
- Short circuit protection.
- Loop open function - loop off under logic control.
- On hook transmission.

The Ag1110 has been designed to work in private systems where cost is a major concern and advanced public network signalling is not a requirement.

The system interface has been designed for direct connection to popular codecs for both audio and signalling.

The Ag1110 is ideal for any application where high-density line interfacing is required, such as Computer Telephony Integration (CTI), Small Office Home Office (SOHO) and PABX.

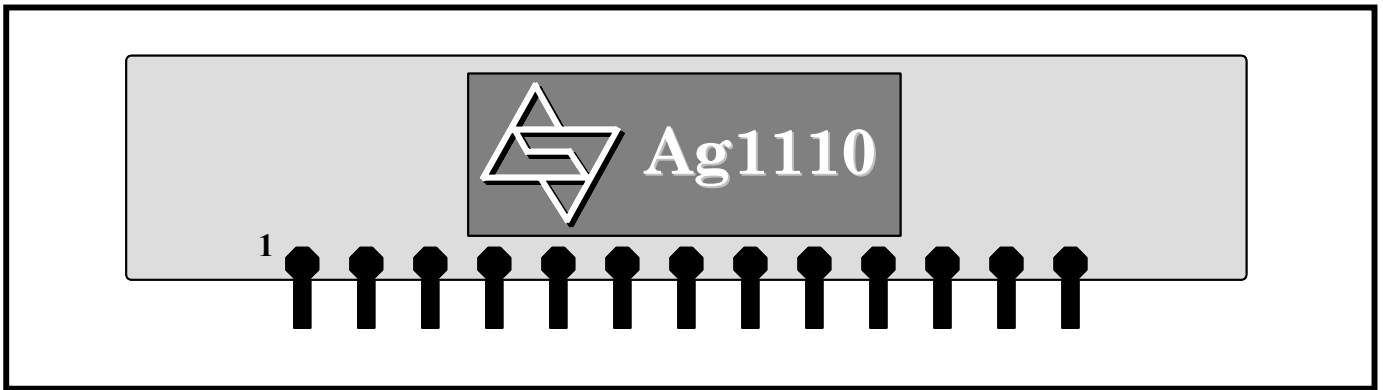

Figure 2: Packaging Format

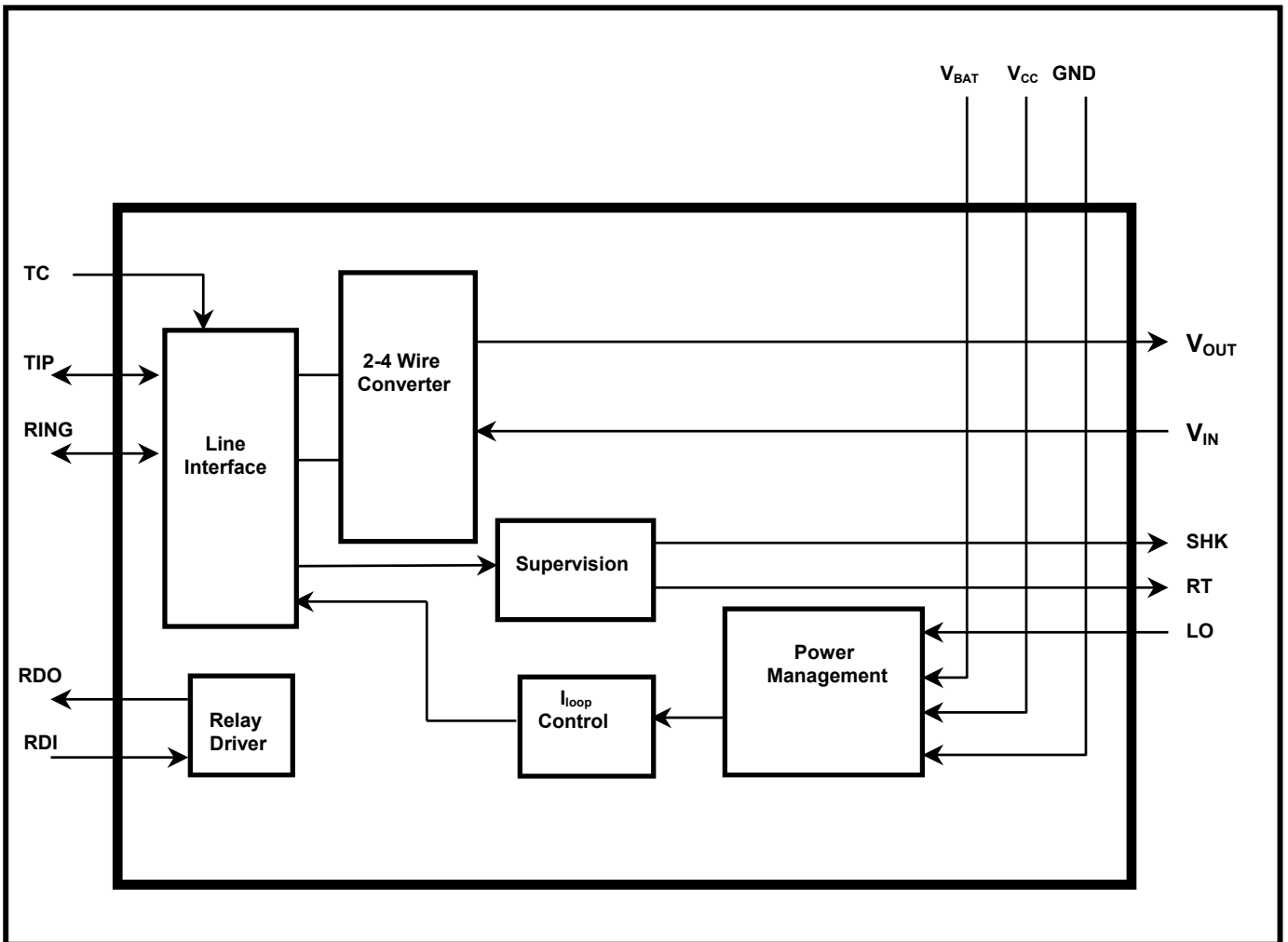

Figure 3: Functional block diagram

Pin Description

Pin #	Name	Description
1	RING	Ring. Connects to the subscriber line Ring through the n/c pole of the ringing relay.
2	TIP	Tip. Connects to the subscriber Tip.
3	TC	Tip Clamp. A diode must be connected externally between TC and Tip to conduct ringing current.
4	RT	Ring Trip. A capacitor is connected externally between RT and GND to filter out the AC component of the ringing signal. Must be switched out during LD dialling.
5	GND	Analog Ground. Normally connected to system ground.
6	V _{IN}	Audio In. This is the analog input signal from the codec (which is output on Tip and Ring).
7	V _{CC}	+5V Positive Supply. This pin must be connected to +5V.
8	V _{OUT}	Audio Out. This is the analog output signal (from Tip and Ring) to the codec.
9	V _{BAT}	Battery Voltage. The negative supply rail. Typically -48V.
10	SHK	Switch Hook Current. Indicates loop current is flowing (such as when off hook) when at logic 1.
11	LO	Loop Off. A logic 1 removes loop current, used during fault conditions.
12	RDI	Relay Driver Input. A logic 1 activates RDO.
13	RDO	Relay Driver Output. Open collector relay driver, connects to the coil of the ringing relay.

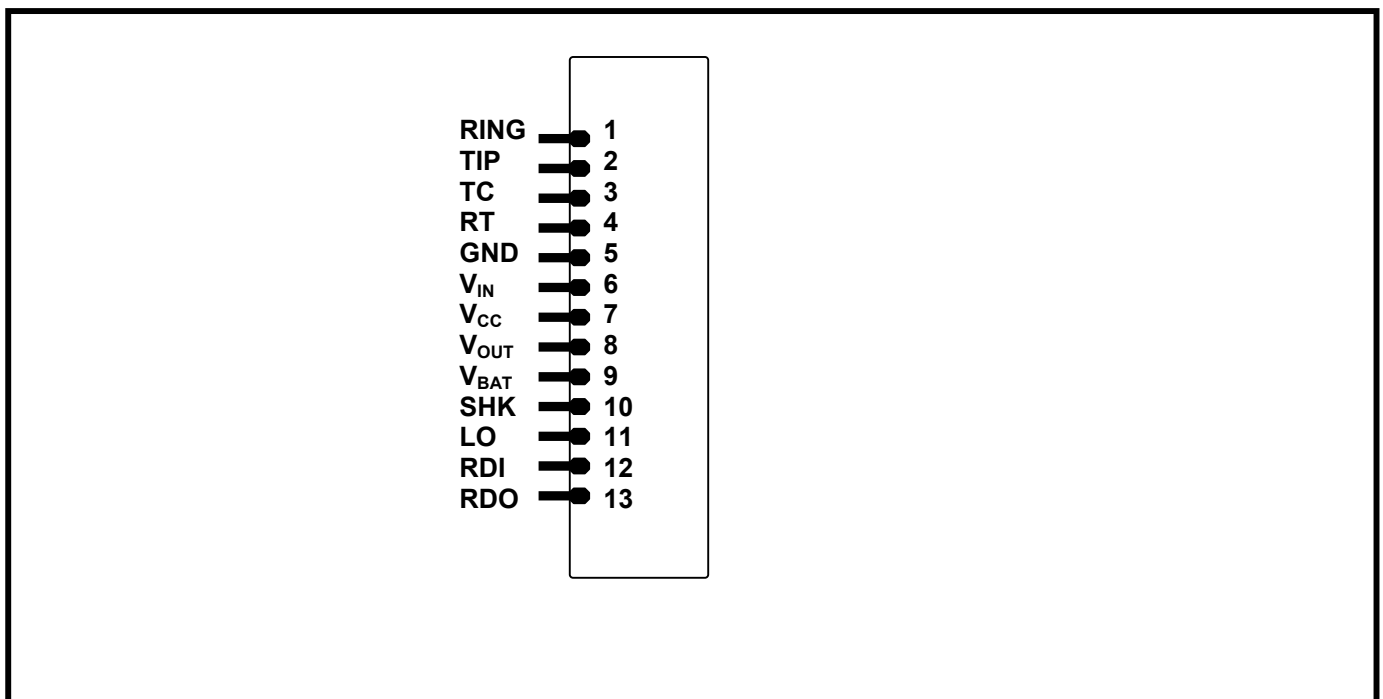

Figure 4: Pin Connections

1.0 Line Interfacing

As well as being in an electrically demanding environment, the needs of different applications and regulatory standards means that the SLIC must allow flexibility, together with facilities to ensure robust performance. The Ag1110 SLIC provides a complete and flexible interface to the telephone line.

1.1 Battery Feed

The battery feed to the telephone line used by the Ag1110 can vary between -42V and -72V. For public network applications -48V is the most common. A constant current is fed to the line, which is preset to 25mA.

If the loop length is such that the constant current feed cannot be maintained, then the Ag1110 will revert to a constant voltage source, allowing the loop to be serviced at a reduced loop current. Typically with a 2000R loop, and -48V battery voltage, loop current is 18.5mA.

The power dissipated in the Ag1110 SLIC is internally limited to a safe value.

1.3 Ringing

The ringing signal is provided by an external ringing generator and is switched onto the line by the user provided ringing relay. The coil of the ringing relay should be connected to a positive supply voltage (normally +5V) and the open collector driver RDO. The relay is activated by applying a logic high to RDI. Note: a flyback diode must be connected across the coil.

Unbalanced ringing is supported on the Ag1110 via the use of a single external relay (with single pole changeover). An application drawing is shown in Fig 5.

When the "off-hook" condition occurs during ringing (as indicated when SHK produces a logic level 1), a logic level 0 should be applied to RDI. This will deactivate the relay, and remove the ringing signal from the line. The SLIC will then assume it's constant current feed condition.

2.0 The 2-4 Wire (hybrid) Conversion.

This is also referred to as the hybrid function. The Ag1110 transmits and receives balanced 2-wire analog signals at the Tip and Ring connections. These are converted to a ground referenced output at V_{OUT} and from a ground referenced input at V_{IN} .

V_{OUT} and V_{IN} are normally connected to a Codec for conversion to and from a digital Pulse Code Modulated (PCM) stream.

2.1 Transmit and Receive Gain.

The gain in both the transmit direction (TIP/RING to V_{OUT}) and the receive direction (V_{IN} to TIP/RING) is set to -1dB. Normally any gain adjustments required by the user can be made by using the Codec.

2.2 The 2 Wire Impedance.

The input impedance, Z_{in} , of the Ag1110 SLIC is set to 600R. For countries where the line impedance is 600R e.g. North America and the Far East, no external adjustment is required. For countries where an alternative line impedance is used the Codec filter characteristics can be programmed to give the required matching. For countries where the impedance is 900R, the Ag1110-900 can be used where the SLIC impedance is internally fixed at 900R.

The Codec manufacturer will provide information on how Codec programming is accomplished. Programmable Codecs require information about the transfer characteristics of the SLIC with which they are working, which is contained in a ".CIR" netlist. A ".CIR" netlist can be obtained by contacting either Silver Telecom or your local representative, to allow the Codec programming coefficients to be generated.

If a simple Codec is being used, the Ag1110 can only accommodate countries where the line impedance is 600R (Ag1110), or 900R (Ag1110-900).

2.3 Network Balance Impedance.

The network balance impedance, Z_b , is set to 600R for the Ag1110. For countries where the network balance impedance is 600R e.g. North America and the Far East, no external adjustment is required. For 900R balance the Ag1110-900 can be used. For countries where an alternative network balance impedance is used the Codec filter characteristics can be programmed to give the required matching. The ".CIR" netlist is again needed to allow the Codec programming coefficients to be generated.

If a simple Codec is being used the Ag1110 can only accommodate countries where the line impedance is 600R or 900R.

2.5 On Hook Transmission.

The Ag1110 is capable of on-hook transmission with the addition of a 20k, 0.25W resistor from Tip to Ring. This means analog signals can be transmitted from V_{IN} through Tip and Ring and onto the line even when no loop current is flowing. This can be used when sending Caller Line Identification (CLI) information or for other "no ring" calls. With the tip-ring resistor fitted, idle current increases by 2.2mA.

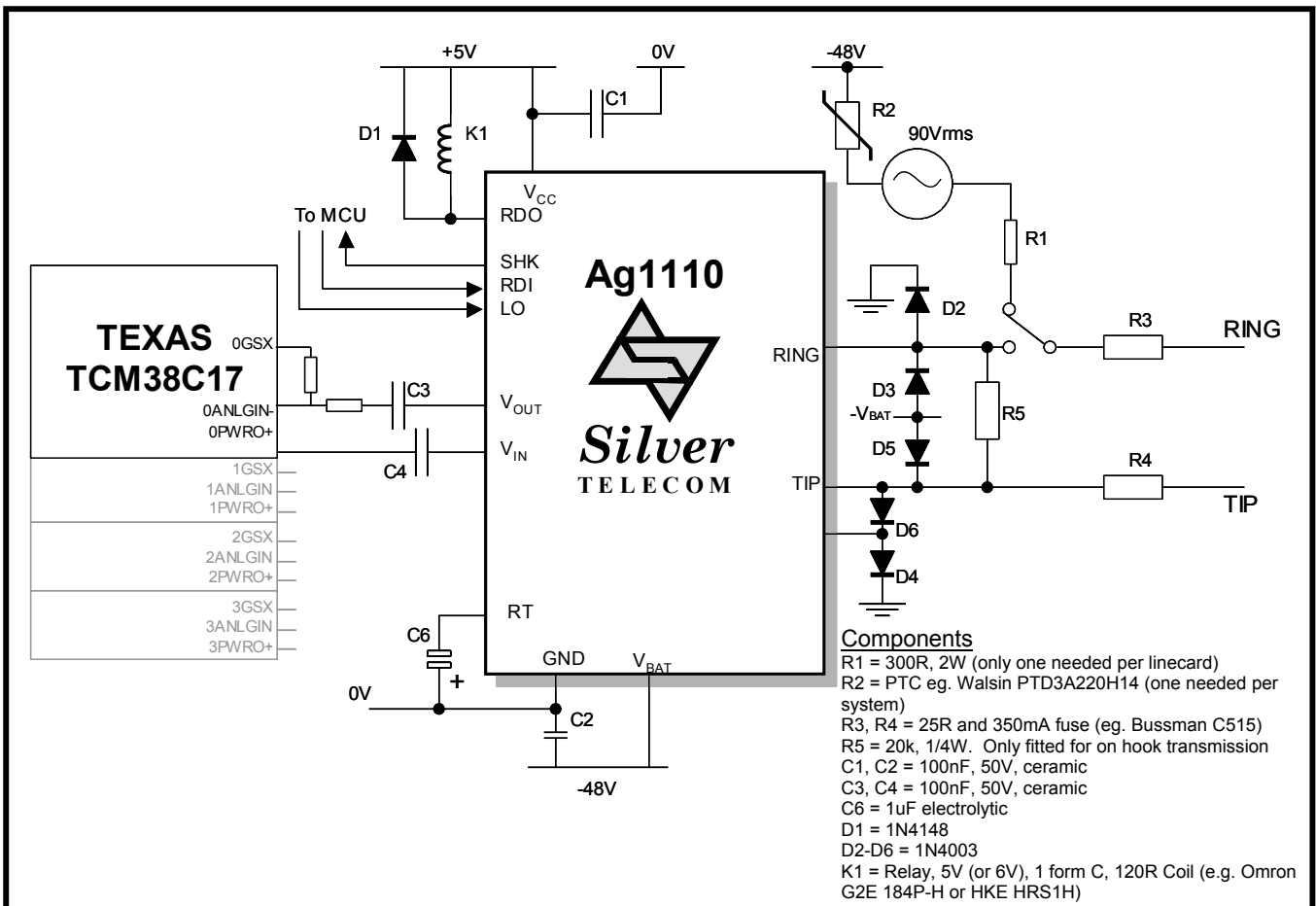

Figure 5: Ringing Application Diagram with Codec

The Ag1110 will provide on hook transmission with a high impedance on Tip/Ring or where specific loads are demanded by Network Operators.

3.0 Loop Current Detect Level

When the subscriber goes "off-hook", loop current will begin to flow. If this current is above the detection threshold (default 10mA), the switch hook output, SHK, will switch to a logic 1. It is recommended that software or hardware de-bouncing of the switch hook signal is used, to avoid short pulses due to contact bounce, causing a false switch hook output triggering the incorrect system response.

During loop disconnect (pulse) dialling, SHK will pulse between logic 1 and logic 0 to indicate the digits being dialled. Again it is recommended that software de-bouncing is used to avoid false detection of digits.

4.0 Relay Driver

On the SLIC an open collector driver, RDO, is provided to drive the ringing relay. This is activated by connecting a logic 1 to RDI. The coil of the user provided ringing relay must be connected between RDO and a positive supply voltage (normally +5V), with

a fly back diode being fitted across the coil. Normally the ringing generator is cadenced, and the ringing relay will only be activated during the off period, as this prolongs the life of the relay contacts.

5.0 Protection

In most 'off-premise' applications the subscriber circuit will be required to withstand over voltage conditions which could be caused by lightning or overhead power cables striking the telephone cables. It is therefore normal to provide primary and secondary protection circuits to prevent damage to the SLIC.

The Ag1110 has been designed to be able to use low cost lightning and power cross protection components, and a typical circuit is shown in Figure 5. This circuit will meet UL1459 and 1950 requirements.

The series element (R3 and R4) is a combination of a fuse (e.g. 350mA, Bussman C515 or Littlefuse 220003), and a surge resistor (25R typically).

Alternatively a Teccor F1250T or F0500T fuse may be used without a surge resistor. The lightning protection is provided by diodes connected to 0V, and the battery voltage. To prevent lightning surges propagating via V_{BAT}, this should be clamped with a Tranzorb device

(Motorola or Protek 1.5KE56A for -48V battery). Alternatively, the steering diodes may be connected to the Tranzorb clamp on its own. This avoids injecting transients into V_{BAT} .

6.0 A Typical Application.

The Ag1110 can interface to most Codecs, and is shown in a typical application in Fig 5. The Codec which has been chosen to illustrate the use of the Ag1110 is the Texas Instruments TCM38C17 quad device.

The TI device has no facilities for impedance matching and is designed for low cost applications. The impedance matching functions are therefore provided by the SLIC circuitry. Therefore to maintain a low solution cost and high integration, no impedance programming components are needed, and only 600R applications can be accommodated (unless using the Ag1110-900, where 900R impedances can be achieved). Where other impedances are required, an "intelligent" codec is required such as the Legerity QSLAC, or the Siemens SICOFI.

Figure 5 shows the usual configuration when DTMF (tone) dialling only is used. In this case C6 is permanently connected. If using LD dialling (also known as loop disconnect or pulse dialling), C6 must be switched out during dialling. Fig 6 shows a typical circuit which could be used in such circumstances.

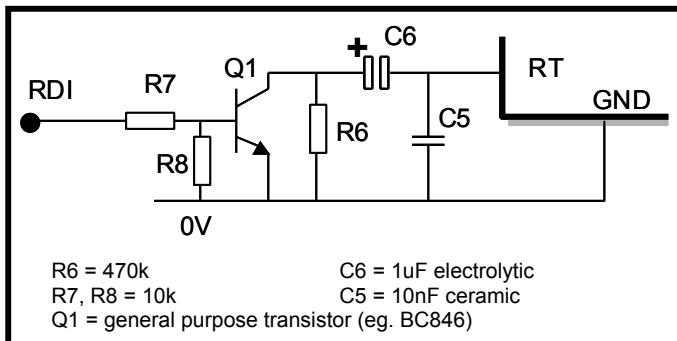

Figure 6: LD Dialling Application

The audio interface is extremely simple, requiring only the d.c. blocking capacitors C3 and C4. Gains are fixed, and therefore again no external components are needed. NOTE: decoupling and noise suppression components used by the TCM38C17 are not shown. The appropriate TI data sheet should be consulted for the correct configuration.

The switch hook detection output (SHK) from the SLICs are passed to the microprocessor interface so that they can then be processed as necessary by the system software. Similarly the Ringing Relay Control (RDI), and loop off (LO) controls are provided by the controlling processor.

The ringing signal is provided by a central ringing generator, through a current limiting resistor (only one needed per line card). The PTC thermistor protects the ringing generator against permanent short circuit. It may not be necessary to fit a PTC where adequate short circuit protection is already provided (eg. with Power Dsine ringing generators).

See paragraph 1.3 for further details on ringing - a ringing application diagram is shown in Fig 5.

6.1 Board Layout Considerations.

When laying out a circuit board, which uses the Ag1110 it is recommended to keep all tracks as short as possible, especially those carrying audio frequency signals. Decoupling capacitors should be used on the power supplies to remove unwanted noise.

The devices should be oriented to maximise the air flow over the SLICs to remove heat. The board should ideally arrange the SLICs in line with the natural air flow creating a "chimney effect".

7.0 Electrical Characteristics.

Absolute Maximum Ratings* - All Voltages are with respect to ground unless otherwise stated.

	Parameter	Symbol	Min	Max	Units
1	DC Supply Voltage	V_{CC}	-0.3	6	V
2	DC Battery Voltage	V_{BAT}	0.3	-75	V
3	Relay Driver Voltage	V_{RDO}	-0.3	15	V
4	Relay Driver Current	I_{DO}		100	mA
5	Power Dissipation, Off Hook @ 25°C	P_{SLIC}		1.35	W
6	Storage Temperature	T_S	-20	+85	°C

* Exceeding the above ratings may cause permanent damage to the product. Functional operation under these conditions is not implied. Maximum ratings assume free air flow.

Recommended Operating Conditions* - All Voltages are with respect to ground unless otherwise stated.

	Parameter	Symbol	Min	Typ	Max	Units
1	DC Supply Voltage	V_{CC}	4.75	5.0	5.25	V
2	DC Battery Voltage	V_{BAT}	-42	-48	-72	V
3	Relay Driver Voltage	V_{RDO}	-0.3	5	15	V
4	Operating Temperature	T_{Op}	0	25	70	°C

* Typical figures are at 25°C with nominal +5V supplies and are for design use only.

DC Electrical Characteristics*

	Characteristic	Symbol	Min	Typ [†]	Max	Units	Test Comments
1	Supply Currents, On-hook	I_{CC1} I_{BAT1} I_{BAT}		1.75 0.25 2.50		mA	Idle Idle 20k Tip-Ring
2	Power Consumption, On-hook	P_{TOT}		22 130		mW	Idle 20k Tip-Ring
3	Constant current feed to line	I_{LOOP}	23 16 15	25 18.5 16.5	27	mA	$R_{LOOP}^{\ddagger} = 1100R$ $R_{LOOP}^{\ddagger} = 2000R$ $R_{LOOP}^{\ddagger} = 2300R$
4	Tip/Gnd or Ring/Gnd or Tip&Ring/Gnd over-current				30	mA	$V_{BAT} = -48V$
5	SHK: Output Low Voltage Output High Voltage	V_{OL} V_{OH}	3.15		0.9	V V	@0.4mA @-0.4mA
6	SHK: Output Low Voltage Output High Voltage	V_{OL} V_{OH}	3.5		0.4	V V	@50uA @-50uA
7	RDI, LO: Input Low Voltage Input High Voltage	V_{IL} V_{OH}	4.0		0.3.	V V	
8	RDI, LO: Input Low Current Input High Current	I_{IL} I_{IH}	-0.5		+1.2	mA mA	
9	Switch Hook Detect Threshold			10		mA	
10	Relay driver current sink capacity	I_{DO}		50	75	mA	$V_{RDI} = +5V$

* All DC Electrical Characteristics are with V_{CC} at +5.0V $\pm 5\%$ and V_{BAT} at -48V, and at 25°C unless otherwise stated.

[†]Typical figures are for design aid only and are not guaranteed.

[‡] R_{LOOP} includes 300R for telephone set.

¹Operating I_{BAT} is dependent upon the users application.

AC Electrical Characteristics.

	Characteristic	Symbol	Min	Typ [†]	Max	Units	Test Comments
1	Ring Trip Detect Time, REN=5			200	300	ms	70V _{RMS} Ringing
2	Ringer Load	REN			5		No false ring trip
3	Input AC Impedance 2-Wire	Z _{IN}		600 900		ohm ohm	Ag1110 Ag1110-900
4	SHK Detect Time			5.0	10	ms	No Ringing, No C6
5	Input Impedance at V _{IN}			100		kohm	
6	Output Impedance at V _{OUT}			10		ohm	
7	Voltage Gain, Tip/Ring to V _{OUT}		-1.5	-1.0	-0.5	dB	Off-Hook
8	Voltage Gain, V _{IN} to Tip/Ring		-1.5	-1.0	-0.5	dB	Off-Hook
9	Relative Gain, Ref to 1kHz		-0.5		-0.5	dB	300Hz to 3400Hz
10	Total Harmonic Distortion @ 2 Wire and V _{OUT}	THD			1.0	%	@ 0dBm, 1kHz, Off hook
11	Overload Distortion @ 2 Wire and V _{OUT}	OD			5.0	%	@ +3dBm, 1kHz, Off hook
12	Overload level at 2 Wire			0		dBm	On hook, 1kHz, AC load = 600R, R _{DC} Tip-Ring = 20k
13	Common Mode Rejection Ratio	CMRR	40	50		dB	300-3400Hz @ 2 Wire
14	Idle Channel Noise	N _C		0	12	dBrnC	@2 Wire and V _{OUT}
15	Power Supply Rejection Ratio @ 2 Wire and V _{OUT}	PSRR	26			dB	Ripple 0.1V, 1kHz on V _{CC} and V _{BAT}
16	Return Loss	RL	18	38		dB	200-3400Hz
17	Transhybrid Loss	THL	18 21	21 24		dB	200-3400Hz 500-2500Hz
18	Longitudinal to Metallic Balance	LCL	40 46	46 50		dB dB	300-600Hz 600-3400Hz

[†] Typical figures are at 25°C with nominal 5V supply and are for design aid only.

8.0 Mechanical Specification.

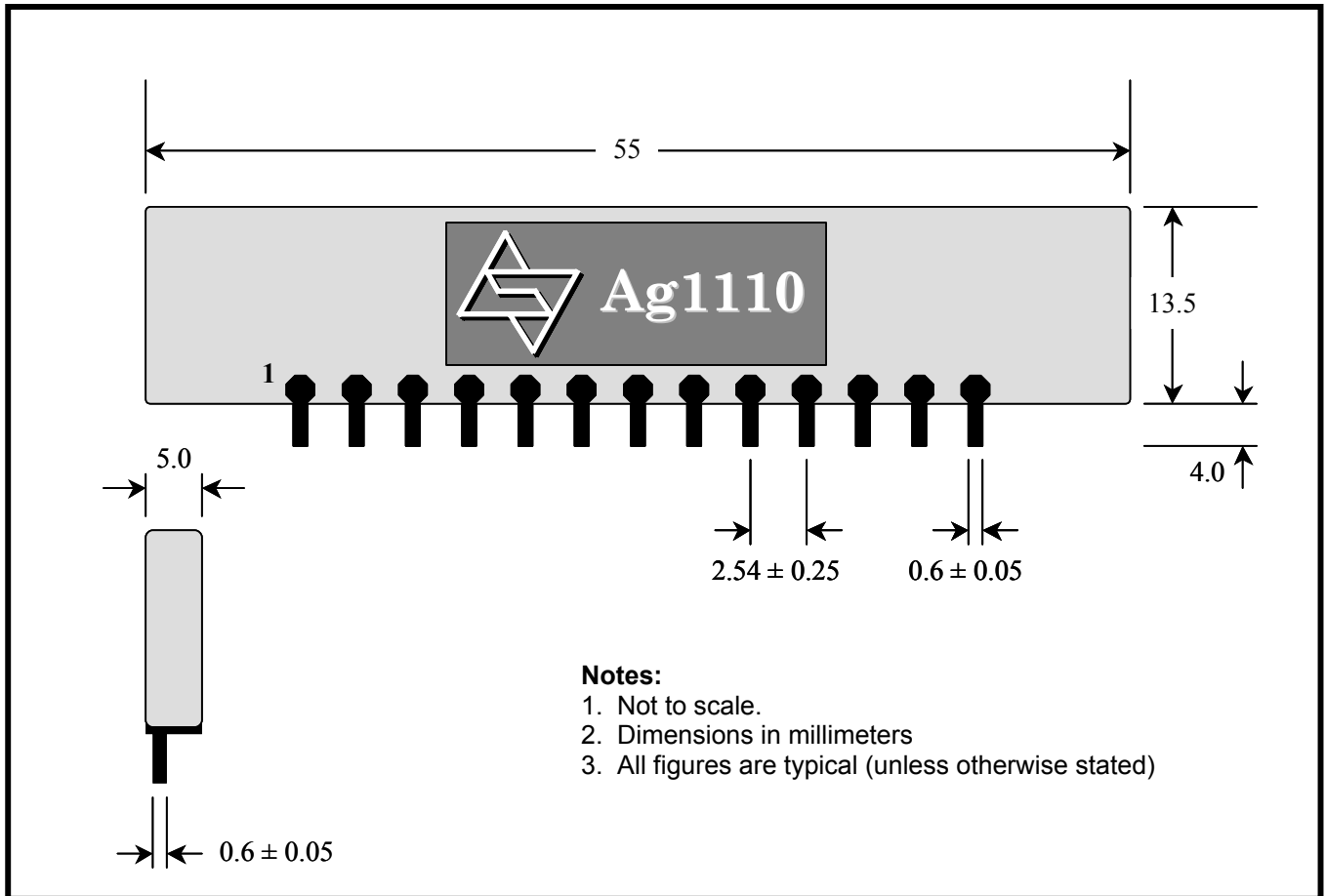

Figure 7: Physical Dimensions