

# TOKENRING NETWORKING COMPONENTS

- Designed for use with multiple Token Ring transceivers, including Texas Instruments C380C30/C60
- IEEE 802.5 compliant
- For use with external on silicon integrated filtering
- Low profile, miniature surface mount packaging
- Cost efficient design approach
- STP/UTP compatible impedances
- Rated to meet 225°C peak IR reflow temperature

## ELECTRICALS AT 25°C

Part No.	Turns Ratio		OCL (μH) Min 1-8	Return Loss (dB) Min		Insertion Loss (dB Max)				Common to Common Mode Rej (dB) Min			Output Impedance		
	1-2-8 to 16-15-13-12	1-2-8 to 10-15-13-9		1-17MHz	17-25MHz	4MHz	8MHz	16MHz	24MHz	5MHz	20MHz	200MHz	1-3	16-12	10-9
S556-5999-01	1CT:1CT	1CT:0.816CT	616	-16	-9	-0.5	-0.8	-1.1	-1.9	-35	-35	-20	150 $\Omega$	150 $\Omega$	100 $\Omega$

## SCHEMATIC

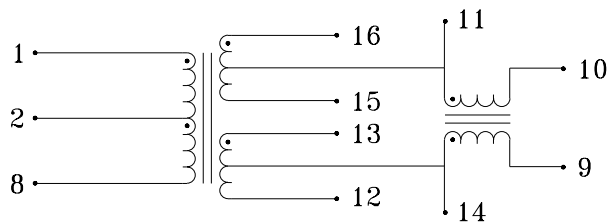

## MECHANICAL

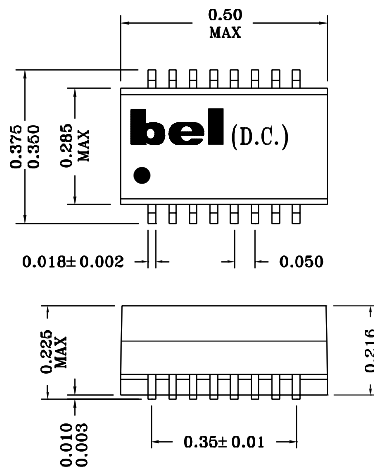

### SUGGESTED PCB PAD LAYOUT

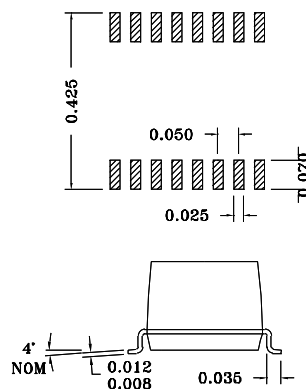

Specifications subject to change without notice.

## TOKENRING NETWORKING COMPONENTS

### APPLICATION CIRCUIT

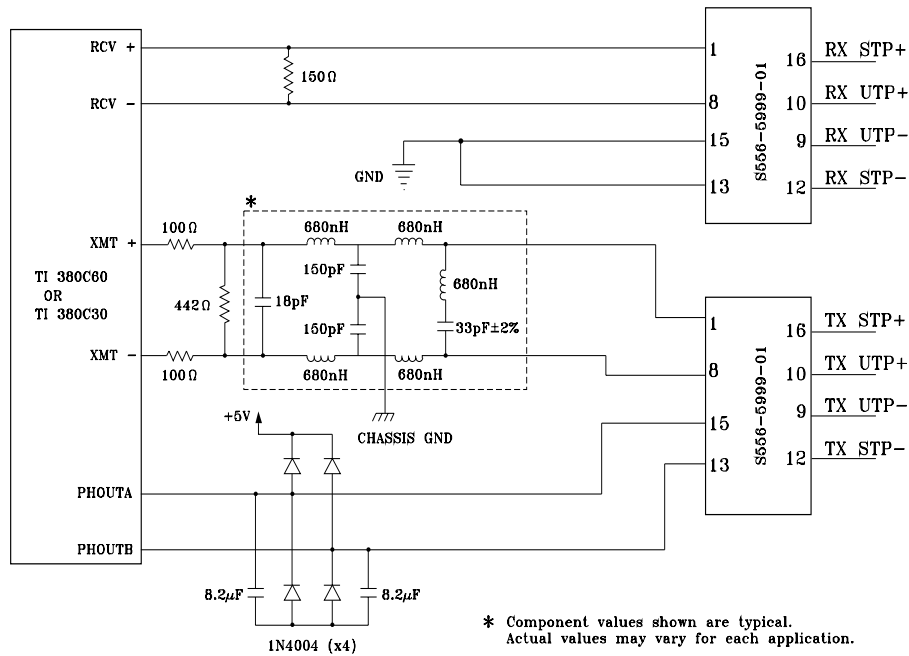

\* Component values shown are typical.  
Actual values may vary for each application.

### APPLICATION NOTES

- Bel has developed this product for use with token ring 4/16 Mbps transceivers in 150 ohm STP and 100 ohm UTP media applications; however, both the 150 ohm and 100 ohm connections cannot be simultaneous. The Bel module provides isolation and impedance matching transformers plus common mode choke for either a transmit or receive channel. External filtering is required.
- Suppression of board induced noise can be achieved with precision layout instructions, along with careful consideration of the selection and placement of discrete components for the interface circuit.
- Bel's low profile, surface mount packaging is ideal for high speed pick and place machinery. Parts can be shipped on tape and reel for high speed placement. Construction processes have been implemented for thermal compatibility with high temperature IR reflow assembly processing. Post dipping of leads assist with PC board solderability. Each part is optically inspected to meet rigid coplanarity requirements.

**Corporate Office**  
**Bel Fuse Inc.**  
198 Van Vorst Street, Jersey City, NJ 07302-4496  
Tel: 201-432-0463  
Fax: 201-432-9542  
E-Mail: [BelFuse@belfuse.com](mailto:BelFuse@belfuse.com)  
Internet: <http://www.belfuse.com>

**Far East Office**  
**Bel Fuse Ltd.**  
8F/8 Luk Hop Street  
San Po Kong  
Kowloon, Hong Kong  
Tel: 852-2328-5515  
Fax: 852-2352-3706

**European Office**  
**Bel Fuse Europe Ltd.**  
Preston Technology Management Centre  
Marsh Lane, Preston PR1 8UD  
Lancashire, U.K.  
Tel: 44-1772-556601  
Fax: 44-1772-888366