

Boca Semiconductor Corp

BSC

Low Noise Tuned Amplifiers.

ABSOLUTE MAXIMUM RATINGS

DESCRIPTION	SYMBOL	VALUE	UNIT
Collector -Base Voltage	VCBO	20	V
Collector -Emitter Voltage	VCEO	12	V
Emitter Base Voltage	VEBO	2.5	V
Collector Current	IC	50	mA
Power Dissipation @ Ta=25 deg C	Ptot	200	mW
@ Tc=25 deg C		300	mW
Operating And Storage Junction Temperature Range	Tj, Tstg	-65 to +200	deg C
Thermal Resistance			
Junction to Case	Rth (j-c)	583	deg C/W
Junction to Ambient	Rth (j-a)	875	deg C/W

ELECTRICAL CHARACTERISTICS (Ta=25 deg C Unless Otherwise Specified)

DESCRIPTION	SYMBOL	TEST CONDITION	MIN	TYP	MAX	UNIT
Collector Cut off Current	ICBO	VCB=15V, IE=0 Ta=150 deg C	-	-	20	nA
		VCB=15V, IE=0	-	-	1.0	uA
Collector -Base Voltage	VCBO	IC=1uA, IE=0	20	-	-	V
Collector -Emitter Voltage	VCEO(sus)	IC=3mA, IB=0	12	-	-	V
Emitter Base Voltage	VEBO	IE=10uA, IC=0	2.5	-	-	V
Collector Emitter Saturation Voltage	VCE(Sat)	IC=10mA, IB=1mA	-	-	0.40	V
Base Emitter Saturation Voltage	VBE(Sat)	IC=10mA, IB=1mA	-	-	1.0	V
DC Current Gain	hFE	IC=3mA, VCE=1V	25	-	250	
DYNAMIC CHARACTERISTICS						
Forward Current Transfer Ratio	hfe	IC=2mA, VCE=6V, f=1kHz	25	-	300	
	ft	IC=5mA, VCE=6V, f=100MHz	900	-	2000	MHz
Out-Put Capacitance	Cob	VCB=10V, IE=0, f=1MHz	-	-	1.0	pF
In-Put Capacitance	Cib	VEB=0.5V, IC=0, f=1MHz	-	-	2.0	pF
Collector Base Time Constant	rbb' Cb' c	IC=2mA, VCE=6V, f=31.9MHz	3.0	-	14	ps
Small-Signal Power Gain	Gp	IC=5mA, VCE=12V, f=200MHz	15	-	-	dB
Common Emitter Oscillator Power Output	Po	IE= -12mA, VCB=10V, f=>500MHz	20	-	-	mW

TO-72 Metal Can Package

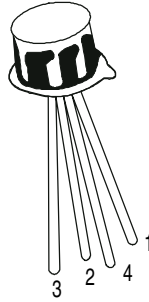
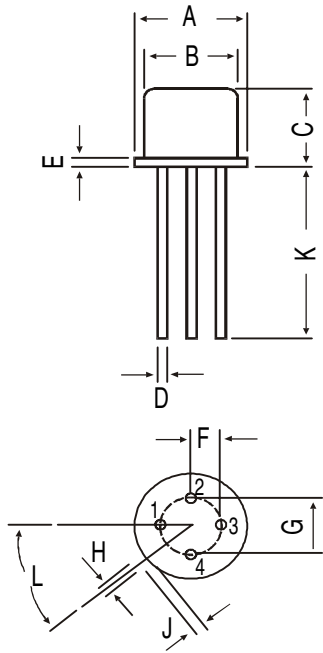

PIN CONFIGURATION

1. EMITTER
2. BASE
3. COLLECTOR
4. CASE

All dimensions in mm.

DIM	MIN.	MAX.
A	5.24	5.84
B	4.52	4.95
C	4.31	5.33
D	0.40	0.53
E	—	0.76
F	1.14	1.39
G	2.28	2.97
H	0.91	1.17
J	0.71	1.22
K	12.70	—
L	12 DEG	48 DEG

Packing Detail

PACKAGE	STANDARD PACK		INNER CARTON BOX		OUTER CARTON BOX		
	Details	Net Weight/Qty	Size	Qty	Size	Qty	Gr Wt
TO-72	1 K/Polybag	325 gm/1K pcs	3" x 7.5" x 7.5"	5.0K	17" x 15" x 13.5"	80.0K	32 kgs

Notes