

MITSUBISHI IGBT Module

MG200Q2YS60A(1200V/200A 2in1)

High Power Switching Applications

Motor Control Applications

- Integrates a complete half bridge power circuit and fault-signal output circuit in one package.
(short circuit and over temperature)
- The electrodes are isolated from case.
- Low thermal resistance
- $V_{CE(sat)} = 2.4 \text{ V (typ.)}$

Equivalent Circuit

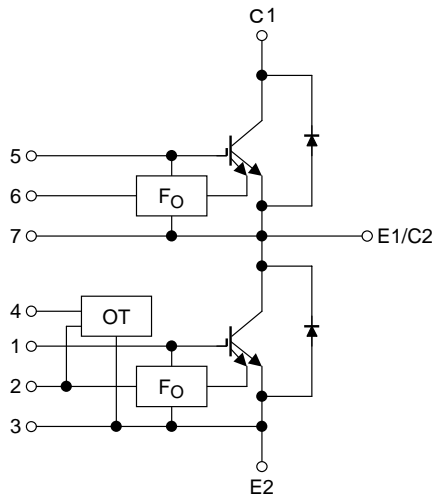

Signal terminal

1.	G (L)	2.	FO (L)	3.	E (L)	4.	V _D
5.	G (H)	6.	FO (H)	7.	E (H)	8.	Open

Package Dimensions

Unit: mm

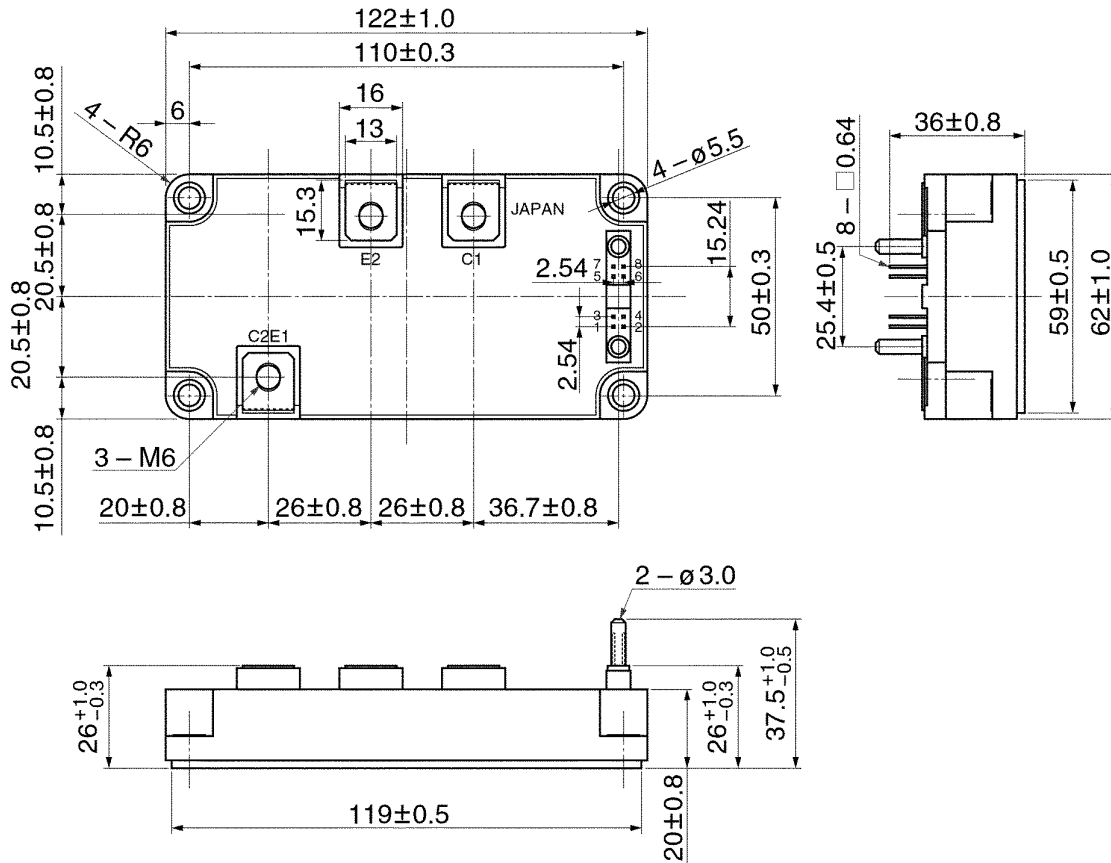

- | | | | | | | | |
|----|-------|----|--------------------|----|-------|----|----------------|
| 1. | G (L) | 2. | F _O (L) | 3. | E (L) | 4. | V _D |
| 5. | G (H) | 6. | F _O (H) | 7. | E (H) | 8. | Open |

Signal Terminal Layout

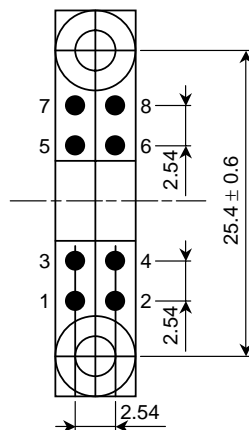

- | | | | | | | | |
|----|-------|----|--------------------|----|-------|----|----------------|
| 1. | G (L) | 2. | F _O (L) | 3. | E (L) | 4. | V _D |
| 5. | G (H) | 6. | F _O (H) | 7. | E (H) | 8. | Open |

Weight: 375 g

Maximum Ratings (Ta = 25°C)

Stage	Characteristics	Symbol	Rating	Unit	
Inverter	Collector-emitter voltage	V_{CES}	1200	V	
	Gate-emitter voltage	V_{GES}	± 20	V	
	Collector current	DC	I_C	200	A
		1 ms	I_{CP}	400	
	Forward current	DC	I_F	200	A
		1 ms	I_{FM}	400	
Collector power dissipation (Tc = 25°C)		P_C	2000	W	
Control	Control voltage (OT)	V_D	20	V	
	Fault input voltage	V_{FO}	20	V	
	Fault input current	I_{FO}	20	mA	
Module	Junction temperature	T_j	150	°C	
	Storage temperature range	T_{stg}	-40~125	°C	
	Operation temperature range	T_{ope}	-20~100	°C	
	Isolation voltage	V_{isol}	2500 (AC 1 min)	V	
	Screw torque	—	3 (M5)	N·m	

Electrical Characteristics (Tj = 25°C)**1. Inverter Stage**

Characteristics		Symbol	Test Condition	Min	Typ.	Max	Unit	
Gate leakage current		I_{GES}	$V_{GE} = \pm 20 \text{ V}, V_{CE} = 0$	—	—	+3/-4	mA	
			$V_{GE} = +10 \text{ V}, V_{CE} = 0$	—	—	100	nA	
Collector cut-off current		I_{CES}	$V_{CE} = 1200 \text{ V}, V_{GE} = 0$	—	—	1.0	mA	
Gate-emitter cut-off voltage		$V_{GE} \text{ (off)}$	$V_{CE} = 5 \text{ V}, I_C = 200 \text{ mA}$	6.0	7.0	8.0	V	
Collector-emitter saturation voltage		$V_{CE} \text{ (sat)}$	$V_{GE} = 15 \text{ V}, I_C = 200 \text{ A}$	$T_j = 25^\circ\text{C}$	—	2.4	2.8	V
				$T_j = 125^\circ\text{C}$	—	—	3.2	
Input capacitance		C_{ies}	$V_{CE} = 10 \text{ V}, V_{GE} = 0, f = 1 \text{ MHz}$	—	15000	—	pF	
Switching time	Turn-on delay time	$t_d \text{ (on)}$	$V_{CC} = 600 \text{ V}, I_C = 200 \text{ A}$ $V_{GE} = \pm 15 \text{ V}, R_G = 10 \Omega$ (Note 1)	0.10	—	1.00	μs	
	Turn-off time	t_{off}		—	—	2.00		
	Fall time	t_f		—	—	0.50		
Reverse recovery time		t_{rr}		—	—	0.50		
Forward voltage		V_F	$I_F = 200 \text{ A}$	—	2.4	2.8	V	

Note 1: Switching time test circuit & timing chart

2. Control (Tc = 25°C)

Characteristics	Symbol	Test Condition	Min	Typ.	Max	Unit
Fault output current	OC	$V_{GE} = 15 \text{ V}$	240	—	—	A
Over temperature	OT	—	100	—	125	°C
Fault output delay time	$t_d \text{ (Fo)}$	$V_{CC} = 600 \text{ V}, V_{GE} = \pm 15 \text{ V}$	—	—	8	μs

3. Module (Tc = 25°C)

Characteristics	Symbol	Test Condition	Min	Typ.	Max	Unit
Junction to case thermal resistance	$R_{th(j-c)}$	Inverter IGBT stage	—	—	0.062	°C/W
		Inverter FRD stage	—	—	0.136	
Case to fin thermal resistance	$R_{th(c-f)}$	With silicon compound	—	0.013	—	°C/W

Switching Time Test Circuit

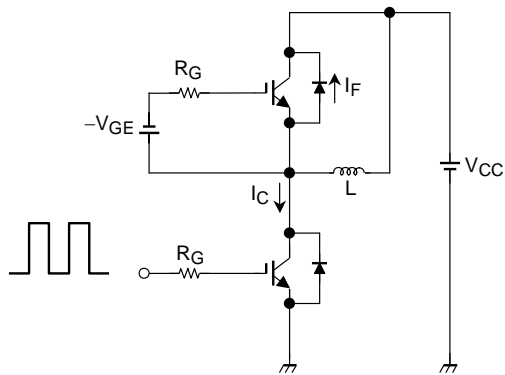

Timing Chart

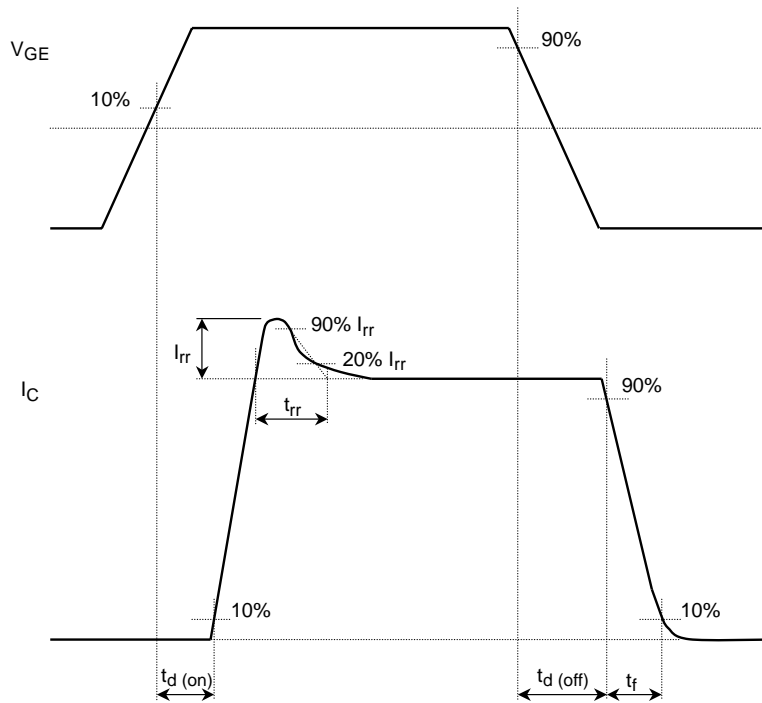

Remark**<Short circuit capability condition>**

- Short circuit capability is 6 μ s after fault output signal.
Please keep following condition to use fault output signal.
 - $V_{CC} \leq 750$ V
 - 14.8 V $\leq V_{GE} \leq 17.0$ V
 - $R_G \geq 10$ Ω
 - $T_j \leq 125^\circ$ C

<Gate voltage>

- To use this product, V_{GE} must be provided higher than 14.8 V.
In case V_{GE} is less than 14.8 V, fault signal FO may not be output even under error conditions.

<Recommended conditions for application>

Characteristics	Symbol	Min	Typ.	Max	Unit
P-N power terminal supply voltage	V_{CC}	—	600	750	V
Gate voltage	V_{GE}	14.8	15	17	V
Gate resistance	R_G	10	—	—	Ω
Switching frequency	fc	—	—	20	kHz

