



Preliminary

## General Description

The MSU30x2 is a monolithic talking microcomputer that can memorize voice up to 60/90/120 seconds using MOSEL qualified coding method(MPCM). It's an integration of traditional 4-bit microcomputer and voice chip with minimal external components. LCD driver and miscellaneous interface are provided for versatile applications. With more than bit 10K ROM/RAM inside, this chip meets every intelligent novelty. Customer requested function and voice data will be built in by changing masks during fabrication.

## Hardware Features

- Low current consumption
- Maximal function with minimal cost
- Current output could drive 8 ohm speaker with a transistor, Vout could drive buzzer directly.
- The voice content is stored up to 120 seconds at 6 KHz (B0000h) and can be separated to 256 sections.
- Duration of each section can be different and is multiples of 100h.
- Duration of section with appended memory-less mute is up to 40 seconds (100000h).
- Each trigger can access a sentence, up to 256 sentences could be access. 1024 entry count are provided.
- Working at 2.4V through 6.0V
- Precise voice sample rate 8 KHz is provided.
- Auto ramp up and ramp down.
- Halt mode is provided.
- Very low current consumption at Halt mode.
- LCD driver provided, can drive up to 75 segments
- Built-In clock generator
- Built-In doubler, halver, tripler
- Internal program ROM : 1024 x 15 bits;
- Internal program RAM : 64 x 4 bits
- Internal stack RAM: 4x10 bits.
- Two 4-bit input ports
- Two 4-bit input/output ports
- One 4-bit output port

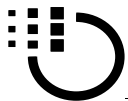

### Software Features

- 76 instructions, in 39 mnemonics
- 4-level subroutine nesting (also used for interrupt)
- Two external factors (INT, S&M) for interrupt
- Two internal factors (timer, divider) for interrupt

### Sample Applications

- handy game with LCD
- versatile timepiece with LCD
- talking timer with LCD
- intelligent calculator with LCD
- smart stationery with LCD
- talking home electronics with LCD
- talking education kit with LCD

### Development Supports

- Development tools are provided
- Software / Hardware programming guide is provided
- OTP U73061 is to be available

- MSM9068 Developing Card
- MSM9088 Program code emulation board
- MSM9018 120" Sound emulation board

### Development Supports

- Pid321 Voice Smart Programmer's Guide
- Pid345 Voice Smart ICE M9068 User's Manual

### Mask Options

- either open or hold transistor on S port & M port
- either pull down or pull up on Interrupt switch
- either leading edge or trailing edge on Interrupt edge
- either power back-up activated or not when power on
- either with reset or not when power on
- either 8 ms or 2 ms chattering removal time on S port & M port
- either slow (by 15.625 ms) or fast (by 224.14 us) set time timer
- either fast system clock ( Fosc) or slow system clock ( Fosc / 2)
- either Rosc or 32768 Hz crystal to play voice
- LCD display frequency : (1) 128 Hz /170.7 Hz (2) 64Hz /85.3 Hz (3) 32Hz /42.7Hz
- LCD driver : (1) static (2) 1/2 bias 1/2 duty (3) 1/2 bias 1/3 duty

### Capacity of each device

	Device	Voice ROM Size	Word Count	Sentence Count	Entry Count	LCD segment	LCD	LCDB	LCDP
1	U3042	B0000hx5	256	256	1024	25x3	Yes	Yes	Yes
2	U3032	81000hx5	256	256	1024	25x3	Yes	Yes	Yes
3	U3022	58000hx5	256	256	1024	25x3	Yes	Yes	Yes



### Block Diagram

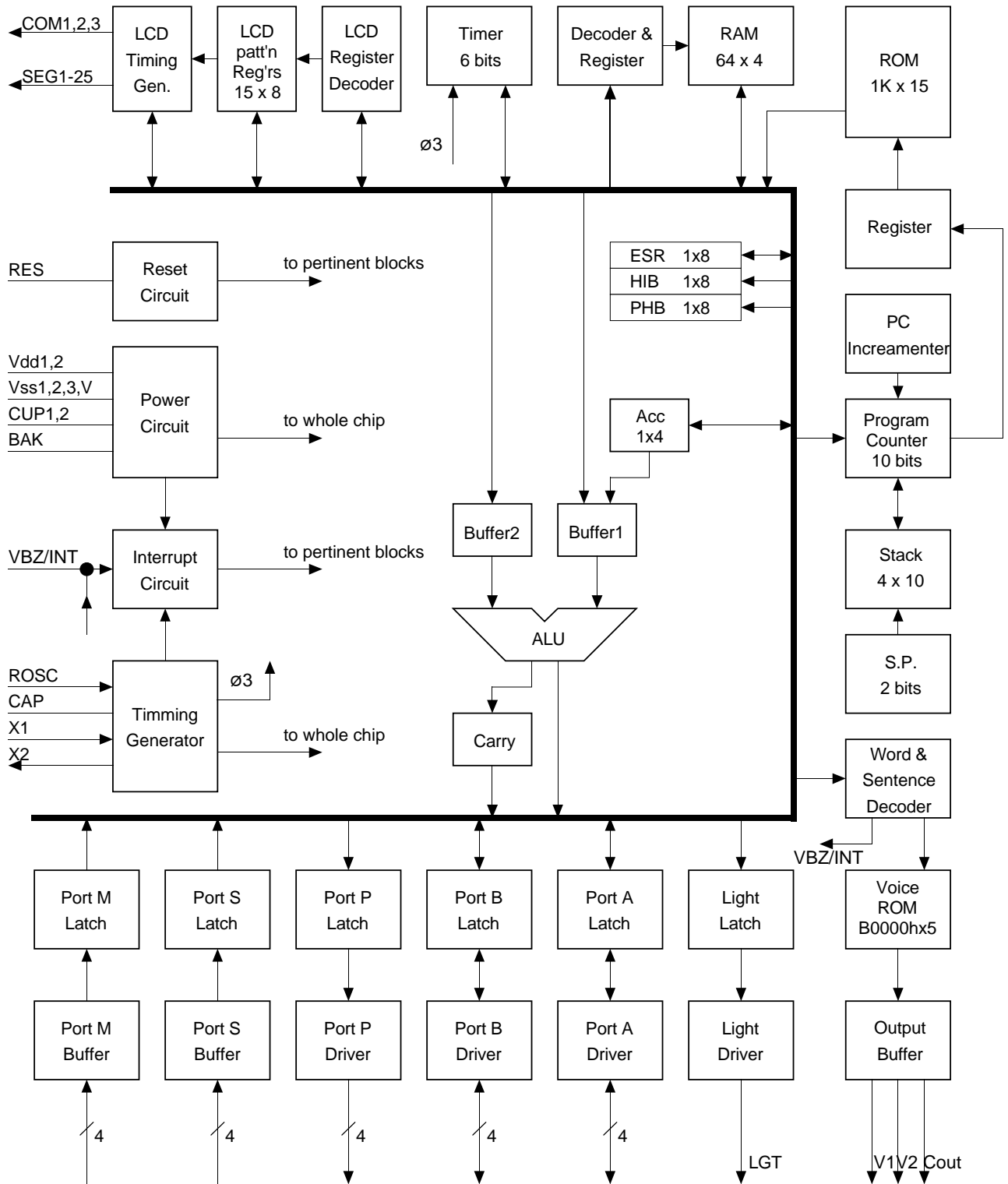

Specifications subject to change without notice, contact your sales representatives for the most recent information.



## Signal Summary

dice Pad #	84L PLCC pin #	Signal symbol		Active	I/O	Functions
63		Vdd1	1		Power	Positive power supply for CPU function block
64		Vreg	1		O	Voltage regulator
65, 66		CUP1,2	2		I	Voltage doubler capacitor
67		X1	1		I	Crystal Oscillator input, 32768 Hz
68		X2	1		O	Crystal Oscillator Output, 32768 Hz
69		COM1	1		O	Common plate for LCD panel
70, 1-24		SEG1-25	25		O	25 segment outputs for LCD panel
25, 26		COM3,2	2		O	Common plate for LCD panel
27		BAK	1		Power	Negative power supply
28, 29		Vss1,2	2		Power	BackUp negative power supply
30, 31		S4,S3	2		I	One-way input port; note 1
32		LGT	1		O	Output port
33-36		IOA1-4	4		I/O	Bidirectional Input / output port
37		RES	1	H	I	System reset
38		NC2	1			No connection
39		NC3	1			No connection
40		Vdd2	1		Power	Positive supply for voice function block, internally connected to pad Vdd1
41		Rosc	1		I	Oscillator Resistor for voice function block
42		VssV	1		Power	Negative power supply for voice signal
43		Cout	1		O	Audio signal current output
44, 45		Vout1,2	2		O	Audio signal voltage output
46-48		IOB1,2,3	3		I/O	Bidirectional Input / Output port
49		NC1	1		I/O	No connection
50		IOB4	1			Bidirectional Input / Output port
51		VBZ/INT	1		I/O	Busy status output; internally connected to INT (interrupt request) pin of CPU
52-55		P1,2,3,4	4		O	One-way output port, 4 bits
56-59		M1,2,3,4	4		I	One-way input port; note 1
60		NC4	1		NC	No connection
61,62		S2,1	2		I	One-way input port, note 1

Note 1. with chatter removal time for either 8 ms (ph8) or 2 ms (ph6)



## Signals Descriptions

### Cout

Cout is tristate during standby.

Cout has zero current output when sound data is zero. Cout has full current output when sound data is the highest. Cout has half of full current output when sound is silence at middle data value. Cout has half of full current output when playing sound at appended memory-less mute.

The bypass Cout Resistor is used to bypass the audio output current from Cout. This bypassing extra current to ground gives a way to prevent the saturation of audio waveform amplified by transistor. This Resistance is 470 ohm typically. It always is not very small. Or user can let it open if the transistor has a fair beta value.

A transistor with beta value 150 is sufficient for typical applications. Larger beta value get larger sound but may have the amplified waveform saturated.

### Vout1, Vout2

They are tristate during standby state.

These two pins can drive buzzer directly. The piezo buzzer used should have its resonant frequency at the center of your sound frequency domain or you are unable to play you sound good by this buzzer.

For instance, you have your sound spans over frequency from 100 Hz through 1 KHz. A buzzer with resonant frequency at 300 Hz will play this sound good. A buzzer with resonant frequency at 1 KHz will distort the sound very much because that most of the energy of the playback sound is unable to be played by this buzzer.

When using precise sample rate, these Vout 1 & 2 do not work.

## Terms

to be available

## Absolute Maximum Rating (Vdd=3.0V, Vss=Vss2=0.0V, Vss3=0.0V/-1.5V)

Symbol	Rating	Unit
Vss1	1.2-1.8	V
BAK	0.0-0.6	V
Vreg	0.0-0.6	V
CAP	Vreg-Vd	V
X1	Vreg-Vdd	V
S1,2,3,4	Vss-Vdd	V
M1,2,3,4	Vss-Vdd	V
(IOA1,2,3,4)TG0,1,2,3	Vss-Vdd	V
IOB1,2,3,4	Vss-Vdd	V
VBZ/INT	Vss-Vdd	V
RESET	Vss-Vdd	V

Symbol	Rating	Unit
Rosc	Vss-Vdd	V
X2	Vreg-Vdd	V
PWR(ALM)	Vss-Vdd	V
#EB2	Vss-Vdd	V
P1,2,3,4	Vss3-Vdd	V
SEG1-25	Vss3-Vdd	V
COM1,2,3	Vss3-Vdd	V
CUP1,2	Vss3-Vdd	V
Vout1,2	Vss-Vdd	V
T(operating)	-60-+60	Degree C
T(storage)	-55-+125	Degree C

## Common Plate Usage

	Static	1/2 duty	1/3 duty
COM1	V	V	V
COM2	-	V	V
COM2	-	-	V
Alternating Frequency	32 Hz	32 Hz	43 Hz

## Operating Conditions

Timing	Description	Min.	Typ.	Max.	Unit	Condition
T A	Ambient temperature under bias	0	2.5	70	°C	
Vdd	Snpply voltage	2.4	4.5	6.0	V	Vss=0V
Xosc	Oscillation frequency for CPU	32768	32768	32768	Hz	
Vosc	Oscillation frequency for playing voice		6000		Hz	

## AC Characteristics at 4.5 V & 6 KHz S.R.

Timing	Min.	Typ.	Max.	Remarks



**DC Characteristics at 3.0 Vdd**

Symbol	Name	Valid	Min.	Typ.	Max.	Unit	Remarks
I <sub>sb</sub>	stand by I	Vdd	-	8	-	uA	
I <sub>op</sub>	operation I	Vdd	-	100	-	uA	
I <sub>ohv</sub>	output high I	Vouts	-	-	-	mA	
I <sub>oLv</sub>	output low I	Vouts	-	-	-	mA	
I <sub>co</sub>	current output	Cout	-	2.5	-	mA	
		Cout	-	-	-	mA	
d F/F	frequency stability		-5	-	5	%	[Fosc(3.0V)-Fosc(2.7V)]/Fosc(3.0V)
d F/F	frequency variation		-10	-	10	%	6 KHz S.R., 680 kohm Rosc
R <sub>osc</sub>	oscillation R	Rosc	-	680	-	kohm	S.R.=6000 Hz
		Rosc	-	620	-	kohm	S.R.=8000 Hz

**DC Characteristics at 4.5 Vdd**

Symbol	Name	Valid	Min.	Typ.	Max.	Unit	Remarks
I <sub>sb</sub>	stand by I	Vdd	-	10	-	uA	
I <sub>op</sub>	operation I	Vdd	-	500	-	uA	
I <sub>ohv</sub>	output high I	Vouts	-	-	-	mA	
I <sub>oLv</sub>	output low I	Vouts	-	-	-	mA	
I <sub>co</sub>	current output	Cout	-	4	-	mA	
		Cout	-	-	-	mA	
V <sub>ohp</sub>	o/p high V	P port	*-0.4V	-	-	V	I <sub>oh</sub> = -400 uA
V <sub>oLp</sub>	o/p low V	P port	-	-	*+0.4V	V	I <sub>oL</sub> = 400 uA
V <sub>ohw</sub>	o/p low V	PWR	*-0.4V	-	-	V	I <sub>oh</sub> = -1 mA
V <sub>oLw</sub>	o/p high V	PWR	-	-	*+0.4V	V	I <sub>oL</sub> = 1 mA
V <sub>ohio</sub>	o/p low V	i/o port	*-0.4V	-	-	V	I <sub>oh</sub> = -100 uA
V <sub>oLio</sub>	o/p high V	i/o port	-	-	*+0.4V	V	I <sub>oL</sub> = 100 uA
V <sub>ohc</sub>	o/p low V	Com	*-0.4V	-	-	V	I <sub>oh</sub> = -4 uA
V <sub>oLc</sub>	o/p high V	Com	-	-	*+0.4V	V	I <sub>oL</sub> = 4 uA
V <sub>ohg</sub>	o/p low V	Seg's	*-0.4V	-	-	V	I <sub>oh</sub> = -0.4 uA
V <sub>oLg</sub>	o/p high V	Seg's	-	-	*+0.4V	V	I <sub>oL</sub> = 0.4 uA
d F/F	frequency stability		-5	-	5	%	[Fosc(4.5V)-Fosc(4.0V)]/Fosc(4.5V)
d F/F	frequency variation		-10	-	10	%	6 KHz S.R., 680 kohm Rosc
R <sub>isn</sub>	input R when on	S port	-	330	-	kohm	pulldown X'tor=on & note 1
R <sub>isf</sub>	input R when off	S port	-	30	-	kohm	pulldown X'tor=off, halt mode & note 1
R <sub>imn</sub>	input R when on	M port	-	30	-	kohm	pulldown X'tor=on & note 1
R <sub>imf</sub>	input R when off	M port	-	30	-	kohm	pulldown X'tor=off, halt mode & note 1
R <sub>inh</sub>	input R	VBZ,INT	-	140	-	kohm	Vss2=0V, Vi=Vdd, VBZ=high
R <sub>inL</sub>	input R	VBZ,INT	-	3	-	kohm	Vss2=0V, Vi=Vdd, VBZ=low
R <sub>ir</sub>	input R	RESET	-	18	-	kohm	Vss2=0V, Vi=Vdd
R <sub>osc</sub>	oscillation R	Rosc	-	680	-	kohm	S.R.=6000 Hz
		Rosc	-	620	-	kohm	S.R.=8000 Hz

Note 1. Vss2=0V, Vi=Vss2+0.4V

Note 2. \*:= Vdd



## Instruction Set Summary

Syntax			Description
1	ADC	A, Rm	Addition with Carry
2	ADC	Wn, d	"
3	ADCS	A, Rm	ADC and store
4	ADCS	Wn, d	"
5	ADD	A, Rm	addition
6	ADD	Wn, d	"
7	ADDS	A, Rm	ADD and store
8	ADDS	Wn, d	"
9	ADL	A, Rm	addition logical
10	ADL	Wn, d	"
11	ADLS	A, Rm	ADL and store
12	ADLS	Wn, d	"
13	AND	A, Rm	move the AND result to Accumulator
14	AND	Wn, d	"
15	ANDS	A, Rm	AND and store
16	ANDS	Wn, d	"
17	CALL	d10	call the subroutine at address d10
18	CLRM	d7	turn the LGT and clear modes
19	CLRS	d9	clear setting
20	HALT		halt the processor
21	IN	Rm, PA	input to Rm from port A
22	IN	Rm, PB	input to Rm from port B
23	IN	Rm, PS	input to Rm from port S
24	IN	Rm, PM	input to Rm from port M
25	INM	Rm, PA	input to Rm from port g
26	INM	Rm, PB	"
27	JC	d10	jump if Carry set
28	JMP	d10	jump absolute
29	JNC	d10	jump if non-Carry
30	JNZ	d10	jump if non-zero
31	JPk	d10	jump on bit k value
32	JZ	d10	jump if zero
33	LCD	Lx, Rm	write number to LCD w/zero
34	LCDB	Lx, Rm	write number to LCD w/blank
35	LCDP	Lx, Rm	write pattern to LCD
36	MOV	HI, d8	move data to HIB
37	MOV	PH, d5	move data to port halt interrupt release byte
38	MOV	Rm, SR2	move ESR to register Rm
39	MOV	Rm, SR1	"
40	MOV	A, Rm	move data to Accumulator from Rm

**Instruction Set Summary** (Continued)

<b>Syntax</b>		<b>Description</b>
41 MOV	Rm, A	move data from Accumulator to Rm
42 MOV	Wn, Rm	move Rm to Accumulator and Wn
43 MOV	CF, Rm	move data from Rm3 to Carry flag
44 MOV	RM, d	move data to Accumulator from Rm
45 MOV	Rm, Wn	"
46 MOV	ALM, 00h	activate a sentence out of 256
47 MOV	TM, d6	move data to timer and start
48 MOV	Rm, CF	move data from Carry flag
49 MOV	IC, d4	move data to interrupt control byte
50 NOP		no operation
51 OR	A, Rm	move the OR result to Accumulator
52 OR	Wn, d	"
53 ORS	A, Rm	OR and store
54 ORS	Wn, d	"
55 OUT	PA, Rm	output from Rm and setting
56 OUT	PB, Rm	"
57 OUT	PP, Rm	output data to port P
58 OUTS	Rm, d	output data to port P serially
59 RET		return from subroutine
60 SBC	A, Rm	subtraction with Carry
61 SBC	Wn, d	"
62 SBCS	A, Rm	SBC and store
63 SBCS	Wn, d	"
64 SETM	d7	turn the #EB2 and set modes
65 SL0	Rm	shift register left and moving
66 SL1	Rm	"
67 SR0	Rm	shift register and moving
68 SR1	Rm	"
69 SUB	A, Rm	subtraction
70 SUB	Wn, d	"
71 SUBS	A, Rm	SUB and store
72 SUBS	Wn, d	"
73 XOR	A, Rm	move the XOR result to Accumulator
74 XOR	Wn, d	"
75 XORS	A, Rm	XOR and store
76 XORS	Wn, d	"

Note. Refer to Voice Smart Programmer's Guide (pid321) for details of each instruction.











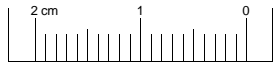

**COB Information I**

Silk screen & copper print

COB model number : M9201  
Chip bonded : U30x2



Legend

-  Copper pad for X'tal
-  Copper pad for LCD
-  Copper pad for LCD
-  Copper pad
-  Through hole
-  Through hole
-  Alignment hole for Jig

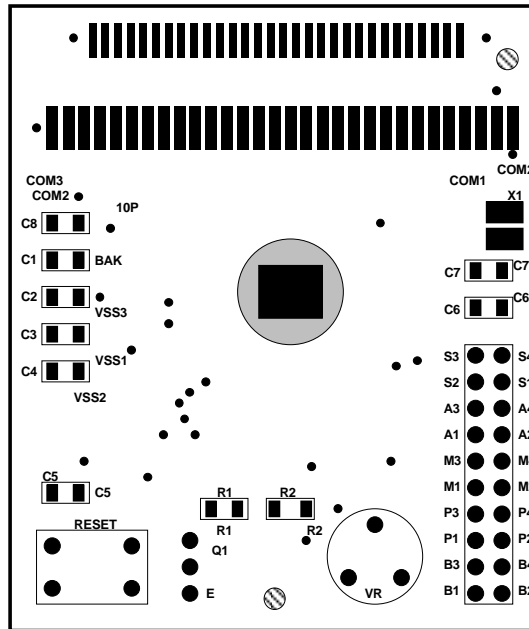





**Timing Diagram**

To be Available soon

**Standard Code Line Up**

To be Available soon



### Typical Application Circuit

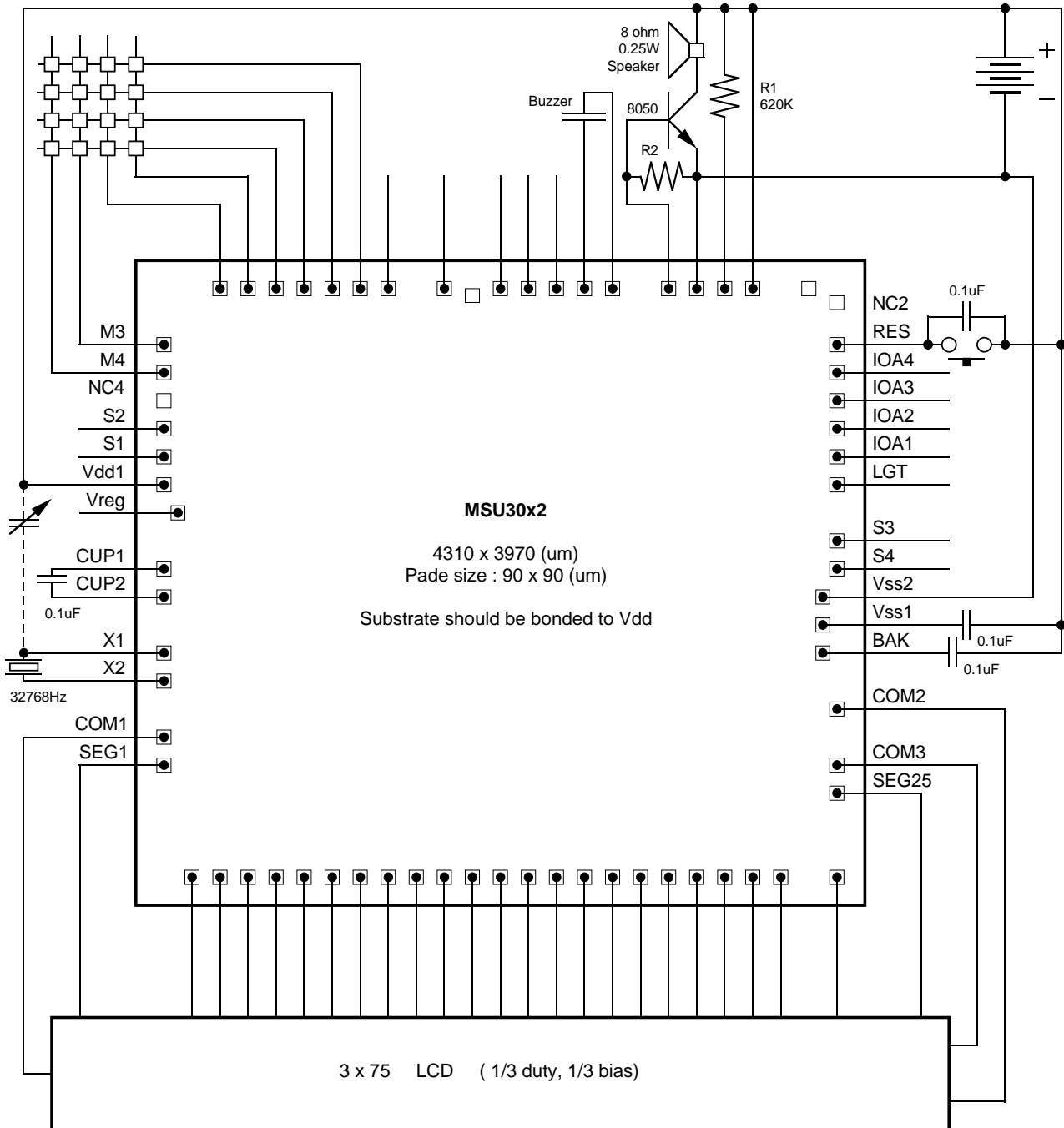

Note: All the above components need to adjust possibly case by case to meet required performance.

Specifications subject to change without notice, contact your sales representatives for the most recent information.

**Bonding Pad Information**

Pad No.	Designation	X	Y	Pad No.	Designation	X	Y
1	SEG2	-1775	-1827	36	IOA4	1985	1156
2	SEG3	-1618	-1827	37	RES	1986	1349
3	SEG4	-1450	-1827	38	NC2	1995	1657
4	SEG5	-1294	-1827	39	NC3	1905	1824
5	SEG6	-1126	-1827	40	Vdd2	1525	1827
6	SEG7	-970	-1827	41	ROSC	1300	1827
7	SEG8	-801	-1827	42	VssV	1080	1827
8	SEG9	-645	-1827	43	COUT	920	1827
9	SEG10	-477	-1827	44	VOUT1	625	1826
10	SEG11	-321	-1827	45	VOUT2	408	1826
11	SEG12	-153	-1827	46	IOB1	254	1826
12	SEG13	3	-1827	47	IOB2	87	1826
13	SEG14	171	-1827	48	IOB3	-58	1826
14	SEG15	327	-1827	49	NC1	-252	1783
15	SEG16	495	-1827	50	IOB4	-430	1826
16	SEG17	651	-1827	51	VBZ/INT	-654	1826
17	SEG18	820	-1827	52	P1	-821	1826
18	SEG19	976	-1827	53	P2	-967	1826
19	SEG20	1144	-1827	54	P3	-1132	1826
20	SEG21	1300	-1827	55	P4	-1277	1826
21	SEG22	1468	-1827	56	M1	-1458	1827
22	SEG23	1625	-1827	57	M2	-1685	1827
23	SEG24	1995	-1757	58	M3	-1995	1627
24	SEG25	1995	-1127	59	M4	-1995	1401
25	COM3	1995	-943	60	NC4	-1995	1191
26	COM2	1995	-707	61	S2	-1995	1015
27	BAK	1908	-416	62	S1	-1995	789
28	Vss1	1908	-275	63	Vdd1	-1995	629
29	Vss2	1932	-129	64	VREG	-1962	467
30	S4	1986	31	65	CUP1	-1994	56
31	S3	1986	257	66	CUP2	-1994	-158
32	LGT	1985	519	67	X1	-1995	-464
33	IOA1	1985	700	68	X2	-1995	-633
34	IOA2	1985	846	69	COM1	-1995	-955
35	IOA3	1985	1011	70	SEG1	-1995	-1138

**Taiwan**

#1, Creation Road I,  
Science-based Indus. Park,  
Hsinchu, 30077  
Taiwan, ROC  
"audio\_reply@mosel.com.tw"  
TEL: 886-3-578-3344  
FAX: 886-3-579-2955  
FAX: 886-3-578-4732

**Taipei**

7F, #102, Section 3,  
Ming Chung E. Road,  
Taipei,105  
Taiwan, ROC  
TEL: 886-2-2545-1213  
FAX: 886-2-2545-1214  
Mdm: 886-2-2545-1464

**China**

(Vitellic HKG ShenZhen)  
Room#1315, Shenkan Bldg.  
#4, Shangbu central road,  
ShenZhen city, 518028,  
P.R.China  
TEL: 86-755-322-9805  
FAX: 86-755-322-9806  
Mdm: 86-755-332-3995

**Hongkong**

#19, Dai Fu Street,  
Taipo Industrial Estate,  
Taipo, N.T.  
Hongkong  
TEL: 852-2665-4883  
FAX: 852-2664-2406  
FAX: 852-2770-8011  
Mdm: 852-2388-0244

**U.S.A.**

#3910,  
North First Street,  
San Jose,  
CA. 95134-1501  
U.S.A.  
TEL: 1-408-433-6000  
FAX: 1-408-433-0952

**Japan**

WBG Marive West 25F,  
#6, Nakase 2-chome,  
Mihama-ku, Chiba-shi,  
Chiba 261-7125,  
Japan  
TEL: 81-43-299-6000  
FAX: 81-43-299-6555

http://www.moselvitelic.com



T O : Mosel Vitelic Inc. 886-3-5772788 (fax)
Attention : Sales & Marketing Department

MSU3042

3 digit production code

filled by MVI only

Product Request Form

We hereby request MVI to start preparing produce MSU3042 which is specified as below descriptions titled [ ] as well as form A and form(s) B and form(s) C.

I already read this data sheet pid 262\* and understand MSU3042 completely and know how to specify to fit my requirement. The voice length limit is B0000h.

Table with 2 main columns: General Descriptions and Chip Descriptions. It contains various fields for customer information, sound files, code files, and power source options.

Phone # : \_\_\_\_\_ Fax # : \_\_\_\_\_
Company Name : \_\_\_\_\_
Signature : \_\_\_\_\_ Date: \_\_\_\_\_
Name Typed : \_\_\_\_\_
Position Title : \_\_\_\_\_
Department, Section : \_\_\_\_\_

Hardcopy of cover page of U3032, U3022 PRF (product request form) are provided per request.



TITLE	
-------	--

Product Request Form A : Mask Definitions

Mask options	Selections
1 Power bias	<input checked="" type="checkbox"/> Li - 1/2 Bias
2 LCD driver & display frequency	<input type="checkbox"/> 1/2 duty 128 Hz <input type="checkbox"/> 1/2 duty 64 Hz <input type="checkbox"/> 1/2 duty 32 Hz <input type="checkbox"/> 1/3 duty 170.7 Hz <input type="checkbox"/> 1/3 duty 85.3 Hz <input type="checkbox"/> 1/3 duty 42.7 Hz <input type="checkbox"/> Static 128 Hz <input type="checkbox"/> Static 64 Hz <input type="checkbox"/> Static 32 Hz
3 S-port defined	<input type="checkbox"/> Open <input type="checkbox"/> Hold transistor
4 M-port defined	<input type="checkbox"/> Open <input type="checkbox"/> Hold transistor
5 Interrupt switch	<input type="checkbox"/> Pull down <input type="checkbox"/> Pull up
6 Interrupt edge	<input type="checkbox"/> Rising <input type="checkbox"/> Falling
7 Power-on mode	<input checked="" type="checkbox"/> BackUp <input type="checkbox"/> Non-BackUp
8 External Reset	<input type="checkbox"/> and PowerOn reset <input type="checkbox"/> Only
9 <sup>note</sup> Chatter Removal time	<input type="checkbox"/> 8 mS time <input type="checkbox"/> 2 mS time
10 <sup>note</sup> Set time	<input type="checkbox"/> Slower (Tk=512 mS) <input type="checkbox"/> Faster (Tk=8000uS)
11 Oscillator	<input checked="" type="checkbox"/> Crystal
12 System Clock	<input type="checkbox"/> Fast (Fosc) <input type="checkbox"/> Slow (Fosc/2)
13 Alarm frequency	<input checked="" type="checkbox"/> Level shift
14 P-port	<input checked="" type="checkbox"/> Level shift
15 <sup>note</sup> Input port signal	<input checked="" type="checkbox"/> Level shift
16 Light mode	<input checked="" type="checkbox"/> Always
17 Reset level	<input checked="" type="checkbox"/> High
18 I/O port	<input checked="" type="checkbox"/> Level shift
19 Light	<input checked="" type="checkbox"/> Level shift

Note 9 : For S port and M port

Note 10 : Set time = (set value + 1) \* Tk / Fosc ; Fosc is in KHz

Note 15 : Input port control signal level shift, J48, J49

How many words are defined ? (1 ≤    ≤ 256)  
And Forms are attached:  B1     B2     B3     B4

How many sentences are defined ? (1 ≤    ≤ 256)  
And Forms are attached:  C1     C2     C3     C4     C5     C6     C7     C8



**Product Request Form B1 : Voice Word Definitions**

**TITLE**

Address	Voice Description	VoiceLength	MuteLength	WordTotal ≤ 100000h	There are <input type="text"/> ≤ <input type="text"/> words defined on this form.			
00		S 00h	S 00h	00h	32	S	00h	S 00h
01		S 00h	S 00h	00h	33	S	00h	S 00h
02		S 00h	S 00h	00h	34	S	00h	S 00h
03		S 00h	S 00h	00h	35	S	00h	S 00h
04		S 00h	S 00h	00h	36	S	00h	S 00h
05		S 00h	S 00h	00h	37	S	00h	S 00h
06		S 00h	S 00h	00h	38	S	00h	S 00h
07		S 00h	S 00h	00h	39	S	00h	S 00h
08		S 00h	S 00h	00h	40	S	00h	S 00h
09		S 00h	S 00h	00h	41	S	00h	S 00h
10		S 00h	S 00h	00h	42	S	00h	S 00h
11		S 00h	S 00h	00h	43	S	00h	S 00h
12		S 00h	S 00h	00h	44	S	00h	S 00h
13		S 00h	S 00h	00h	45	S	00h	S 00h
14		S 00h	S 00h	00h	46	S	00h	S 00h
15		S 00h	S 00h	00h	47	S	00h	S 00h
16		S 00h	S 00h	00h	48	S	00h	S 00h
17		S 00h	S 00h	00h	49	S	00h	S 00h
18		S 00h	S 00h	00h	50	S	00h	S 00h
19		S 00h	S 00h	00h	51	S	00h	S 00h
20		S 00h	S 00h	00h	52	S	00h	S 00h
21		S 00h	S 00h	00h	53	S	00h	S 00h
22		S 00h	S 00h	00h	54	S	00h	S 00h
23		S 00h	S 00h	00h	55	S	00h	S 00h
24		S 00h	S 00h	00h	56	S	00h	S 00h
25		S 00h	S 00h	00h	57	S	00h	S 00h
26		S 00h	S 00h	00h	58	S	00h	S 00h
27		S 00h	S 00h	00h	59	S	00h	S 00h
28		S 00h	S 00h	00h	60	S	00h	S 00h
29		S 00h	S 00h	00h	61	S	00h	S 00h
30		S 00h	S 00h	00h	62	S	00h	S 00h
31		S 00h	S 00h	00h	63	S	00h	S 00h

Length summation of above 64 words is  00h

Signature & date  MVI Sales & date  All words' length sum'n is  ≤ limit 00h

**Harcopy of complete set PRF (product request form) pages B2-B4 and C1 - C8 are provided per request.**