

High Power GaAs SPDT Switch

Features:

- ◆ 3x3x0.9mm Packaged pHEMT Switch
- ◆ Excellent low control voltage performance
- ◆ Excellent harmonic performance under GSM/DCS/PCS/EDGE power levels
- ◆ Very high Tx-Rx isolation: >28dB typ. at 1.8GHz
- ◆ Very low Insertion loss: 0.5dB at 1.8GHz
- ◆ Very low control current

Functional Schematic

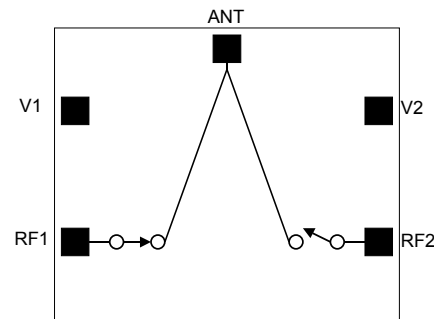

Description and Applications:

The FMS2014QFN is a low loss, high power and linear single pole double throw Gallium Arsenide antenna switch designed for use in mobile handset applications. The die is fabricated using the Filtronic FL05 0.5 μ m switch process technology, which offers excellent performance optimised for switch applications. The FMS2014QFN is designed for use in dual/tri and quad band GSM handset antenna switch modules and RF front-end modules. It can also find use in other applications where high power and linear RF switching is necessary.

Electrical Specifications: (T_{AMBIENT} = 25°C, V_{ctrl} = 0V/2.5V, Z_{IN} = Z_{OUT} = 50 Ω)

Parameter	Test Conditions	Min	Typ	Max	Units
Insertion Loss	0.5 – 1.0 GHz		0.45		dB
	1.0 – 2.0 GHz		0.5		dB
Return Loss	0.5 – 2.5 GHz		20		dB
Isolation	0.5 – 1.0 GHz		-32		dB
	1.0 – 2.0 GHz		-30		dB
2nd Harmonic Level	1 GHz, Pin = +35 dBm, 100% Duty Cycle		-75		dBc
	2 GHz, Pin = +35 dBm, 100% Duty Cycle		-75		dBc
3rd Harmonic Level	1 GHz, Pin = +35 dBm, 100% Duty Cycle		-75		dBc
	2 GHz, Pin = +35 dBm, 100% Duty Cycle		-75		dBc
Switching speed : Trise, Tfall Ton, Toff	10% to 90% RF and 90% to 10% RF		<0.3		μ s
	50% control to 90% RF and 50% control to 10% RF			1.0	μ s
Control Current	+35dBm RF input @1GHz		<10		μ A

Note: External DC blocking capacitors are required on all RF ports (typ: 100pF)

Absolute Maximum Ratings:

Parameter	Symbol	Absolute Maximum
Max Input Power	Pin	+38dBm
Control Voltage	V ctrl	+5V
Operating Temp	T oper	-40°C to +100°C
Storage Temp	T stor	-55°C to +150°C

Note: Exceeding any one of these absolute maximum ratings may cause permanent damage to the device.

Truth Table:

Switch State	VC1	VC2	ANT- RF1	ANT- RF2
(A)	HIGH	LOW	Insertion Loss	Isolation
(B)	LOW	HIGH	Isolation	Insertion Loss

General Test Conditions:

Bias Voltages	LOW = 0V to 0.2V HIGH +2.5V to +5V
Port Impedances	50Ω
Off arm termination	50Ω

Typical Measured Performance on Evaluation Board (De-Embedded):

(Measurement Conditions $V_{CTRL} = 2.5V$ (high) & $0V$ (low), $T_{AMBIENT} = 25^{\circ}C$ unless otherwise stated)

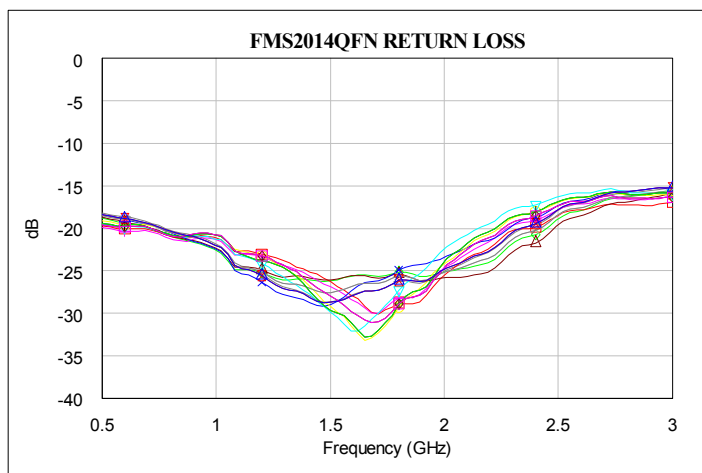
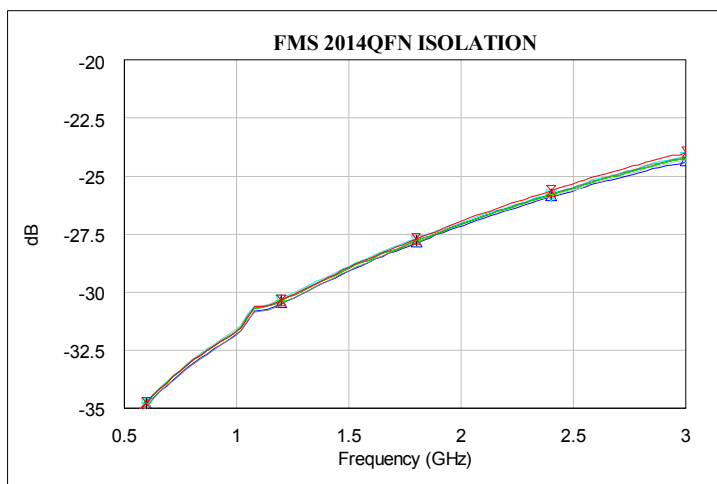
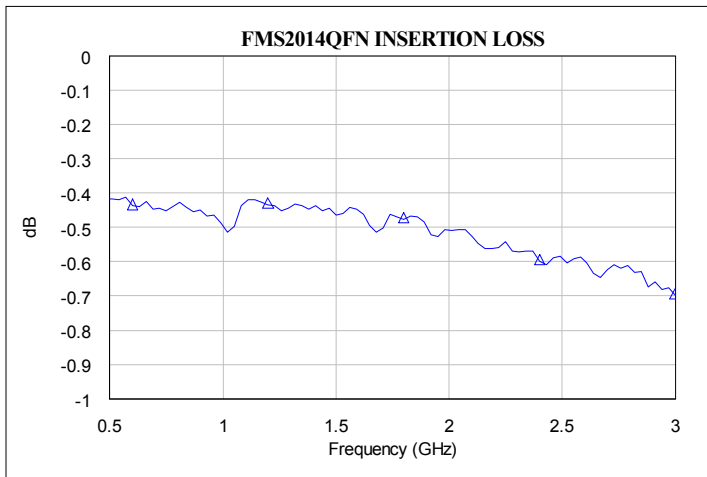

Pad Layout:

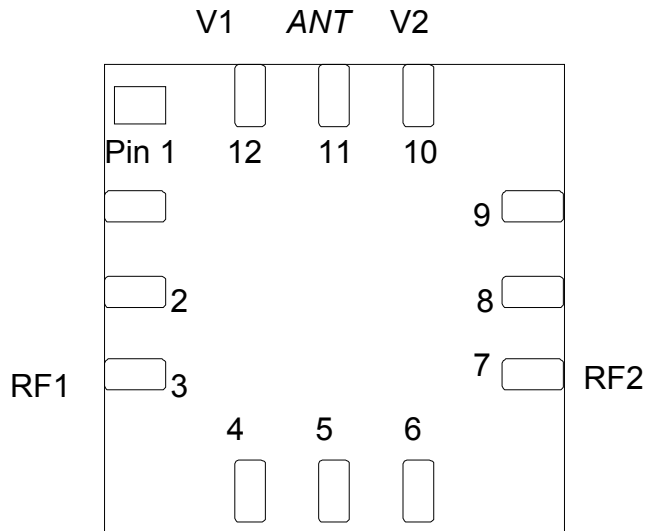

*View from the top of the package

Pin Number	Description
1	N/C
2	N/C
3	RF1
4	N/C
5	N/C
6	N/C
7	RF2
8	N/C
9	N/C
10	V2
11	ANT RF
12	V1

QFN 12 Lead 3*3 Package Outline:

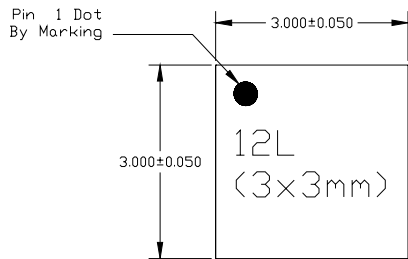

TOP VIEW

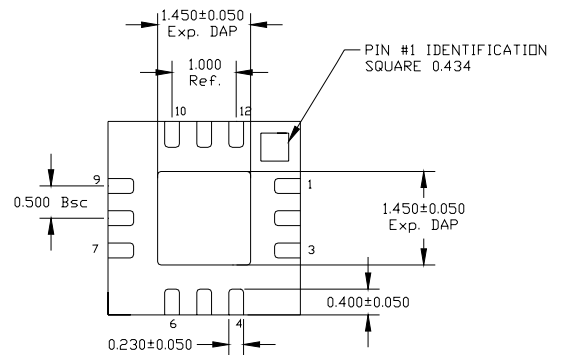

BOTTOM VIEW

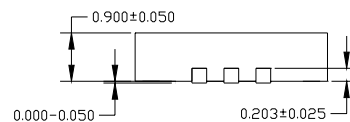

SIDE VIEW

Evaluation Board:

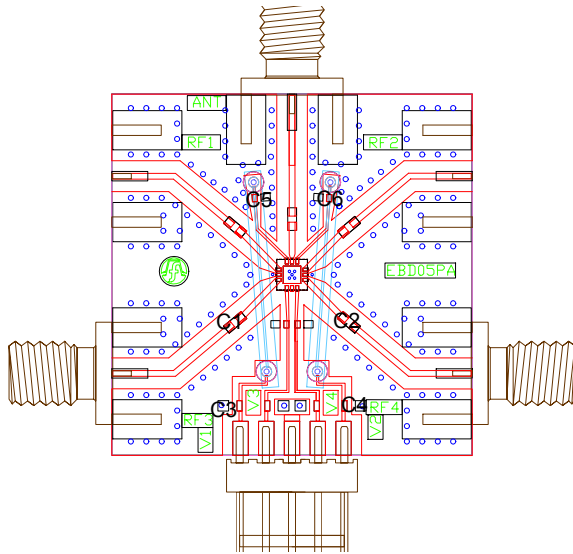

BOM	
Label	Component
C3,C4	Capacitor, 470pF, 0603
C1,C2	Capacitor, 100pF, 0402
C5,C6	Capacitor, 47pF, 0402
BOARD	Preferred evaluation board material is 0.25 mm thick ROGERS RT4350. All RF tracks should be 50 ohm characteristic impedance.

Evaluation Board De-Embedding Data (Measured):

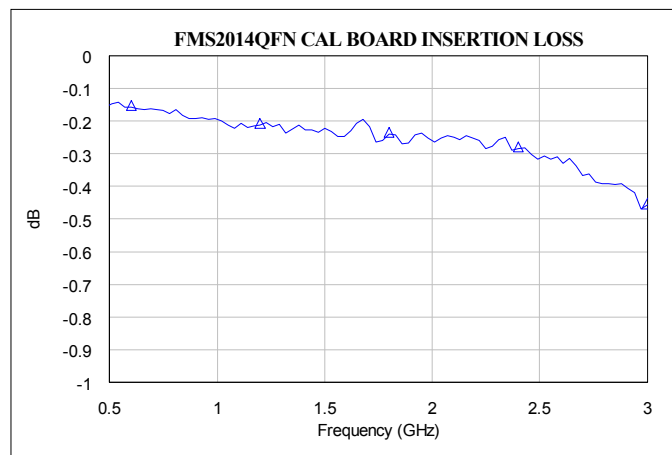

Ordering Information:

Part Number	Description
FMS2014-001	Packaged Die
FMS2014-001-EB	Packaged die mounted on evaluation board

Handling Precautions:

To avoid damage to the devices care should be exercised during handling. Proper Electrostatic Discharge (ESD) precautions should be observed at all stages of storage, handling, assembly, and testing. These devices should be treated as Class 1A (0-500V). Further information on ESD control measures can be found in MIL-STD-1686 and MIL-HDBK-263.

Preferred Assembly Instructions:

Please refer to FCSL applications note: FAN 003 (handling and assembly of Filtronic QFN devices)

Disclaimers:

This product is not designed for use in any space based or life sustaining/supporting equipment.