

FEATURES

- +15.2 dB Gain
- -10 dBm Input IP3
- +3V Single Voltage Supply
- Low Current Consumption: 6mA

APPLICATIONS

- IF or RF Buffer Amplifier
- Driver/Pre-Driver for CATV/SAT TV Amplifier
- ISM Band Transceivers - WLAN - IEEE 802.11, Bluetooth
- GSM/CDMA Receivers

OVERVIEW

The ICL series of Low Noise Amplifiers are general purpose, high performance LNAs designed for operation from 3V supply. The amplifiers housed in a low-cost surface mountable package provide a high output intercept point, high gain and low noise figure and require an external bias resistor for setting the bias current.

The ICL2001-23 can be used for amplification in IF or RF buffer amplifiers. The amplifier provides a gain of 15dB typically at 850 MHz and has single ended input and output. The device can be operated with a single +3V supply.

The IC is available in industry standard 6L-SOT23 package.

FUNCTIONAL BLOCK DIAGRAM

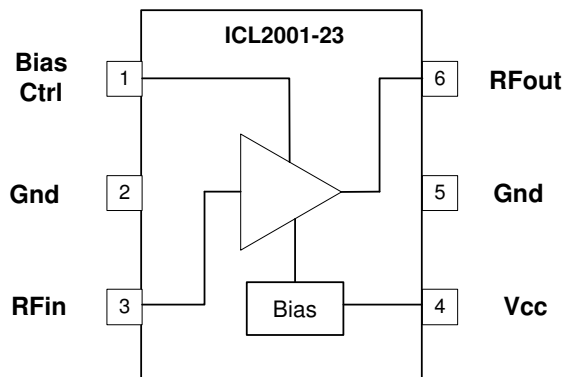

PACKAGE

6L-SOT23

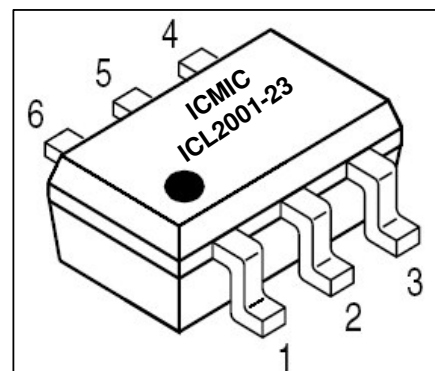
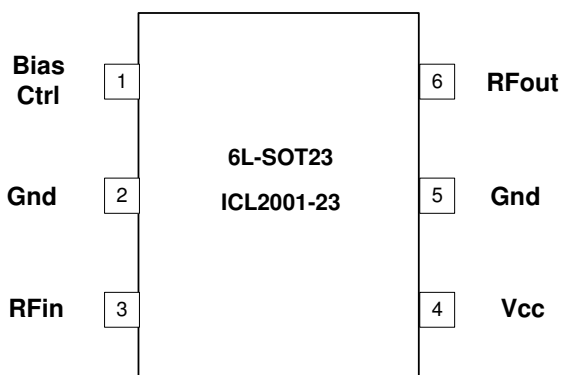

Performance tests for ICmic products were performed internally by ICmic and measured using specific systems and/or components. Any difference in circuit implementation, test software, or test equipment may affect actual performance. The information provided herein is believed to be reliable at the time of this printing. ICmic assumes no responsibility for the use of this information and/or the described product(s). Prices and specifications are subject to change without notice. Copyright 2004 IC MICROSYSTEMS SDN. BHD. All worldwide rights reserved

PIN OUT DESCRIPTION

Pin #	Symbol	Description
1	Bias Ctrl	Bias resistor of appropriate value connected to this pin externally controls the bias current in the circuit and thus the gain.
2	Gnd	Ground connection. Keep traces physically short and immediately connect to ground plane.
3	RFin	RF input pin. This pin is not internally DC blocked and thus requires an external blocking capacitor suitable for the frequency of operation.
4	Vcc	Bias should be supplied to this pin externally. Please note that an RF choke inductor is required. The supply should be well-bypassed.
5	Gnd	Same as Pin 1
6	RFout	RF output pin. This pin is not internally DC blocked and thus requires an external blocking capacitor suitable for the frequency of operation.

ABSOLUTE MAXIMUM RATING

Symbol	Parameter	Value	Unit
V _{CC}	Positive Power Supply	+4.0	V _{DC}
T _{OP}	Operating Temperature	-40 to +85	°C
T _{STG}	Storage Temperature	-65 to +150	°C
T _{SOL}	Soldering Temperature	300	°C

Note: Stress greater than those listed above may cause permanent damage to the device. This is a stress rating only and functional operation of the device at these or any other conditions above those indicated in the operational sections of this specification is not implied. Exposure to absolute maximum rating conditions for extended periods may affect reliability.

ORDERING INFORMATION

Part	Description
ICL2001-23	6L-SOT23, 3V LNA
ICL2001-23-EVAL	Fully Assembled Evaluation Board

TEST CONDITIONS

Parameter	Value	Unit
V _{CC}	+3.0	V _{DC}
T _{OP}	+25	°C

Unless otherwise stated, measurements were done on the evaluation board



Caution! ESD Sensitive Device

Appropriate precaution in handling, packaging and testing must be observed

PRODUCT SPECIFICATIONS

Parameter	Test Conditions	Min	Typ	Max	Unit
Supply Voltage			+3.0		V
Supply Current			6		mA

Parameter	Test Conditions	Min	Typ	Max	Unit
Overall Frequency Range		800	850	900	MHz
850 MHz Performance Gain Noise Figure Input IP3 Input P1dB Input Return Loss Output Return Loss Isolation	$V_{CC}=+3.0V, T_{OP} = +25\text{ }^{\circ}C$		15.2 1.41 -10 -10 12.71 13.82 21.81		dB dB dBm dBm dB dB dB
800 MHz Performance Gain Noise Figure Input Return Loss Output Return Loss Isolation	$V_{CC}=+3.0V, T_{OP} = +25\text{ }^{\circ}C$		15.9 1.38 10.47 17.12 22.18		dB dB dB dB dB

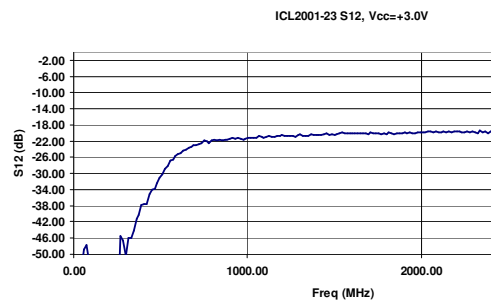
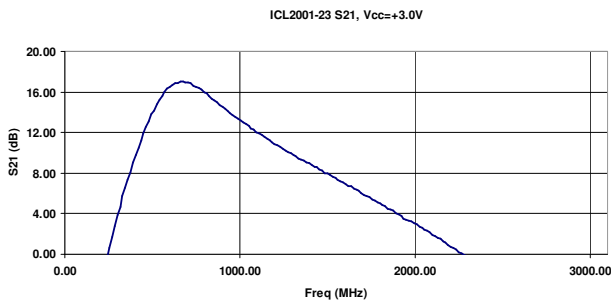
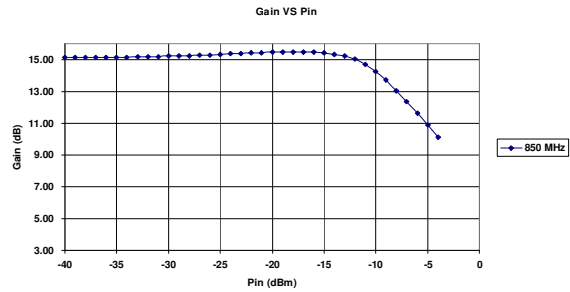
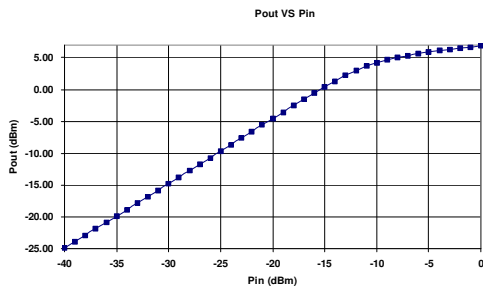

ICL2001-23 S11, Vcc=+3.0V

ICL2001-23 S22, Vcc=+3.0V

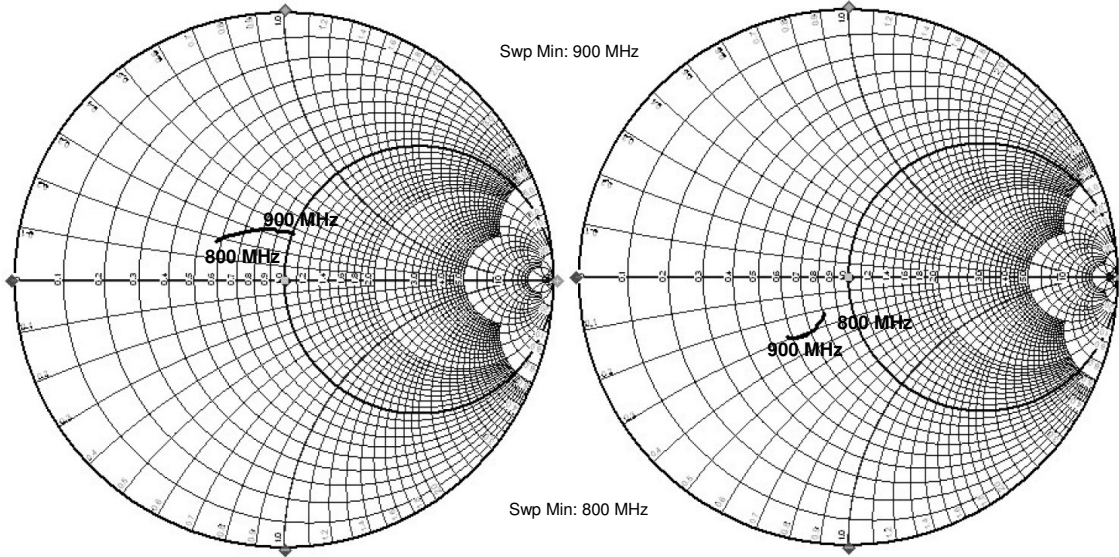

APPLICATION & EVALUATION BOARD SCHEMATIC

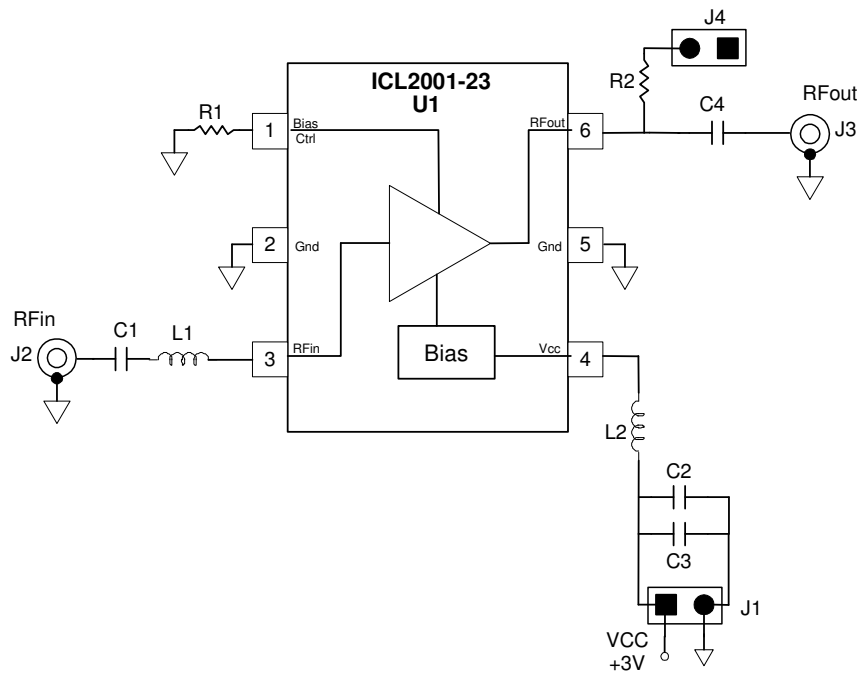

TEST PCB

PCB Top - Component Side

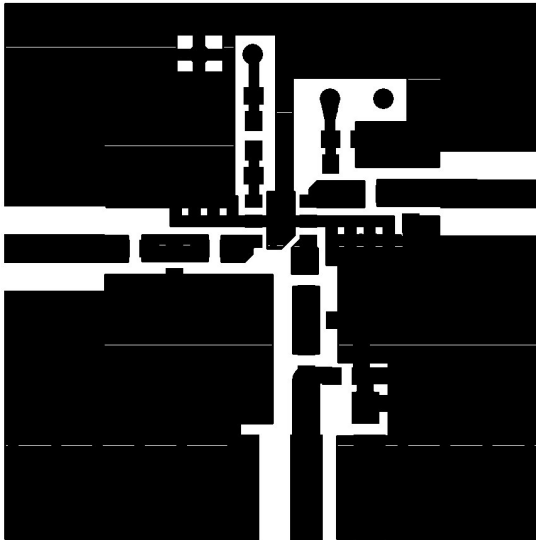

PCB SilkScreen

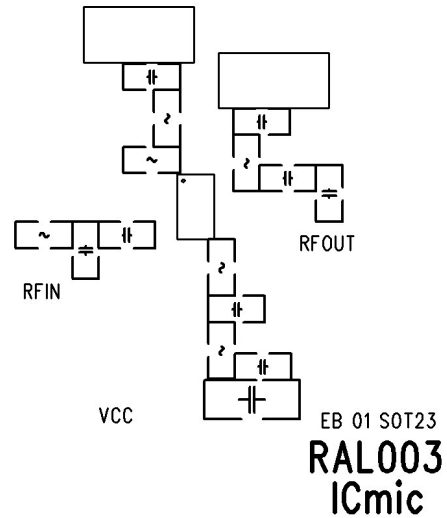

FULLY ASSEMBLED PCB

ICL2001-23 EVAL

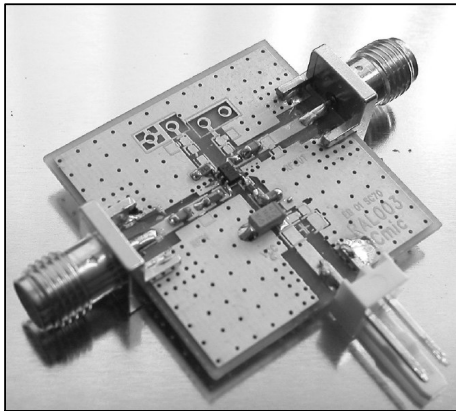

PCB COMPONENTS

Component Designator	Value	Qty	Description
U1		1	ICL2001-23 LNA
J1		1	2 Pin Header - VCC
J2, J3		2	SMA End Launch Connectors
J4		1	2 Pin Header – Gain Cntrl
C1	18 pF	1	Input Match / Blocking Cap
C2	4.7 μ F	1	Bypass Capacitor
C3	470 pF	1	Bypass Capacitor
C4	100 pF	1	Output Match / Blocking Cap
L1	6.8 nH	1	Inductor
L1	5.6 nH	1	Inductor
R1	47 k Ω	1	Bias Cntrl Resistor
R2	1 k Ω	1	Gain Cntrl Resistor

PACKAGE DIAGRAM

6L-SOT23

