

## FEATURES

- 3.3V and 5V power supply options
- 50ps output-to-output skew
- Synchronous enable/disable
- Master Reset for synchronization
- Internal 75KΩ input pull-down resistors
- Available in 16-pin SOIC package



Precision Edge®

## DESCRIPTION

The SY100S834/L is low skew (÷1, ÷2, ÷4) or (÷2, ÷4, ÷8) clock generation chip designed explicitly for low skew clock generation applications. The internal dividers are synchronous to each other, therefore, the common output edges are all precisely aligned. The devices can be driven by either a differential or single-ended ECL or, if positive power supplies are used, PECL input signal. In addition, by using the VBB output, a sinusoidal source can be AC-coupled into the device. If a single-ended input is to be used, the VBB output should be connected to the  $\overline{\text{CLK}}$  input and bypassed to ground via a 0.01μF capacitor. The VBB output is designed to act as the switching reference for the input of the SY100S834/L under single-ended input conditions. As a result, this pin can only source/sink up to 0.5mA of current.

The Function Select (FSEL) input is used to determine what clock generation chip function is. When FSEL input is LOW, SY100S834/L functions as a divide by 2, by 4 and by 8 clock generation chip. However, if FSEL input is HIGH, it functions as a divide by 1, by 2 and by 4 clock generation chip. This latter feature will increase the clock frequency by two folds.

The common enable ( $\overline{\text{EN}}$ ) is synchronous so that the internal dividers will only be enabled/disabled when the internal clock is already in the LOW state. This avoids any chance of generating a runt clock pulse on the internal clock when the device is enabled/disabled as can happen with an asynchronous control. An internal runt pulse could lead to losing synchronization between the internal divider stages. The internal enable flip-flop is clocked on the falling edge of the input clock, therefore, all associated specification limits are referenced to the negative edge of the clock input.

Upon start-up, the internal flip-flops will attain a random state; the master reset (MR) input allows for the synchronization of the internal dividers, as well as for multiple SY100S834/Ls in a system.

## TRUTH TABLE

CLK	$\overline{\text{EN}}$	MR	Function
Z	L	L	Divide
ZZ	H	L	Hold Q0-2
X	X	H	Reset Q0-2

### Notes:

Z = LOW-to-HIGH transition

ZZ = HIGH-to-LOW transition

FSEL	Q0 Outputs	Q1 Outputs	Q2 Outputs
L	Divide by 2	Divide by 4	Divide by 8
H	Divide by 1	Divide by 2	Divide by 4

## PIN NAMES

Pin	Function
CLK	Differential Clock Inputs
FSEL	Function Select
$\overline{\text{EN}}$	Synchronous Enable
MR	Master Reset
VBB	Reference Output
Q0	Differential ÷1 or ÷2 Outputs
Q1	Differential ÷2 or ÷4 Outputs
Q2	Differential ÷4 or ÷8 Outputs

**PACKAGE/ORDERING INFORMATION**

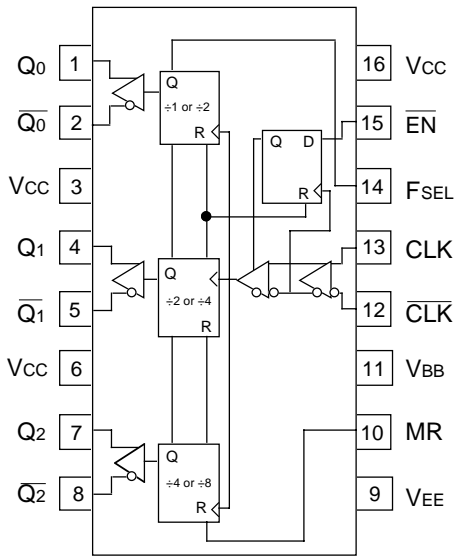

**16-Pin SOIC (Z16-2)**

**Ordering Information**

Part Number	Package Type	Operating Range	Package Marking	Lead Finish
SY100S834ZC	Z16-2	Commercial	SY100S834ZC	Sn-Pb
SY100S834ZCTR <sup>(1)</sup>	Z16-2	Commercial	SY100S834ZC	Sn-Pb
SY100S834LZC	Z16-2	Commercial	SY100S834LZC	Sn-Pb
SY100S834LZCTR <sup>(1)</sup>	Z16-2	Commercial	SY100S834LZC	Sn-Pb
SY100S834ZI	Z16-2	Industrial	SY100S834ZI	Sn-Pb
SY100S834ZITR <sup>(1)</sup>	Z16-2	Industrial	SY100S834ZI	Sn-Pb
SY100S834LZI	Z16-2	Industrial	SY100S834LZI	Sn-Pb
SY100S834LZITR <sup>(1)</sup>	Z16-2	Industrial	SY100S834LZI	Sn-Pb
SY100S834ZG <sup>(2)</sup>	Z16-2	Industrial	SY100S834ZG with Pb-Free bar-line indicator	NiPdAu Pb-Free
SY100S834ZGTR <sup>(1, 2)</sup>	Z16-2	Industrial	SY100S834ZG with Pb-Free bar-line indicator	NiPdAu Pb-Free
SY100S834LZG <sup>(2)</sup>	Z16-2	Industrial	SY100S834LZG with Pb-Free bar-line indicator	NiPdAu Pb-Free
SY100S834LZGTR <sup>(1, 2)</sup>	Z16-2	Industrial	SY100S834LZG with Pb-Free bar-line indicator	NiPdAu Pb-Free

**Notes:**

1. Tape and Reel.
2. Pb-Free package is recommended for new designs.

## DC ELECTRICAL CHARACTERISTICS<sup>(1)</sup>

$V_{EE} = V_{EE} (\text{Min.})$  to  $V_{EE} (\text{Max.})$ ;  $V_{CC} = \text{GND}$

Symbol	Parameter	$T_A = -40^\circ\text{C}$			$T_A = 0^\circ\text{C}$			$T_A = +25^\circ\text{C}$			$T_A = +85^\circ\text{C}$			Unit
		Min.	Typ.	Max.	Min.	Typ.	Max.	Min.	Typ.	Max.	Min.	Typ.	Max.	
I <sub>EE</sub>	Power Supply Current	—	—	49	—	—	49	—	—	49	—	—	54	mA
V <sub>BB</sub>	Output Reference Voltage	-1.38	—	-1.26	-1.38	—	-1.26	-1.38	—	-1.26	-1.38	—	-1.26	V
I <sub>IH</sub>	Input HIGH Current	—	—	150	—	—	150	—	—	150	—	—	150	μA

**Note:**

- Parametric values specified at:
 

5 volt Power Supply Range	100S834 Series:	-4.2V to -5.5V.
3 volt Power Supply Range	100S834L Series	-3.0V to -3.8V.

## AC ELECTRICAL CHARACTERISTICS<sup>(1)</sup>

$V_{EE} = V_{EE} (\text{Min.})$  to  $V_{EE} (\text{Max.})$ ;  $V_{CC} = \text{GND}$

Symbol	Parameter	$T_A = -40^\circ\text{C}$			$T_A = 0^\circ\text{C}$			$T_A = +25^\circ\text{C}$			$T_A = +85^\circ\text{C}$			Unit
		Min.	Typ.	Max.	Min.	Typ.	Max.	Min.	Typ.	Max.	Min.	Typ.	Max.	
t <sub>PLH</sub> t <sub>PHL</sub>	Propagation Delay to Output	960 650	1100 800	1200 1010	960 650	1100 800	1200 1010	960 650	1100 800	1200 1010	960 650	1100 800	1200 1010	ps
t <sub>skew</sub>	Within-Device Skew <sup>(2)</sup>	—	—	50	—	—	50	—	—	50	—	—	50	ps
t <sub>S</sub>	Set-up Time $\overline{\text{EN}}$	400	—	—	400	—	—	400	—	—	400	—	—	ps
t <sub>H</sub>	Hold Time $\overline{\text{EN}}$	200	—	—	200	—	—	200	—	—	200	—	—	ps
V <sub>PP</sub>	Minimum Input Swing	250	—	—	250	—	—	250	—	—	250	—	—	mV
V <sub>CMR</sub>	Common Mode Range <sup>(3)</sup> CLK	-1.3	—	-0.4	-1.4	—	-0.4	-1.4	—	-0.4	-1.4	—	-0.4	V
t <sub>r</sub> t <sub>f</sub>	Output Rise/Fall Times Q (20% – 80%)	275	400	525	275	400	525	275	400	525	275	400	525	ps

**Notes:**

- Parametric values specified at:
 

5 volt Power Supply Range	100S834 Series:	-4.2V to -5.5V.
3 volt Power Supply Range	100S834L Series	-3.0V to -3.8V.
- Within-Device Skew is specified for identical transition.
- The CMR range is referenced to the most positive side of the differential input signal. Normal operation is obtained if the HIGH level falls within the specified range and the peak-to-peak voltage lies between V<sub>PP</sub> min. and 1V. The lower end of the CMR range varies 1:1 with V<sub>EE</sub>. The numbers in the spec table assume a nominal V<sub>EE</sub> = -3.3V. Note for PECL operation, the V<sub>CMR</sub> (min) will be fixed at 3.3V – I<sub>VCMR</sub> (min).

**TIMING DIAGRAM**

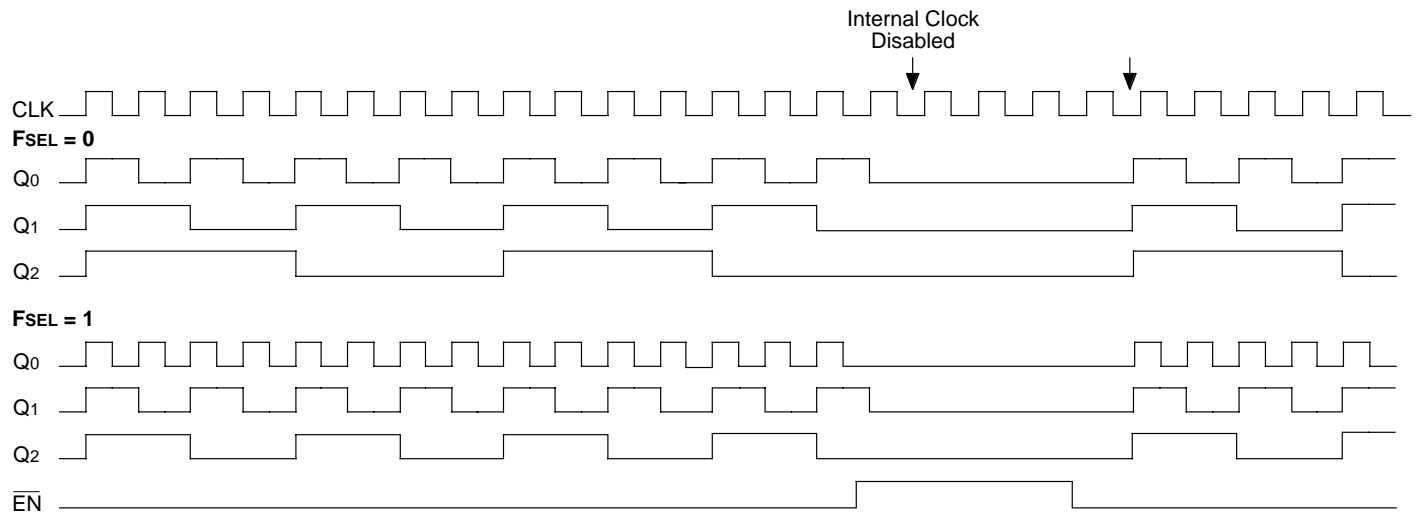

The  $\overline{EN}$  signal will freeze the internal clocks to the flip-flops on the first falling edge of CLK after its assertion. The internal dividers will maintain their state during the internal clock freeze and will return to clocking once the internal clocks are unfrozen. The outputs will transition to their next states in the same manner, time and relationship as they would have had the  $\overline{EN}$  signal not been asserted.

**16-PIN SOIC .150" WIDE (Z16-2)**

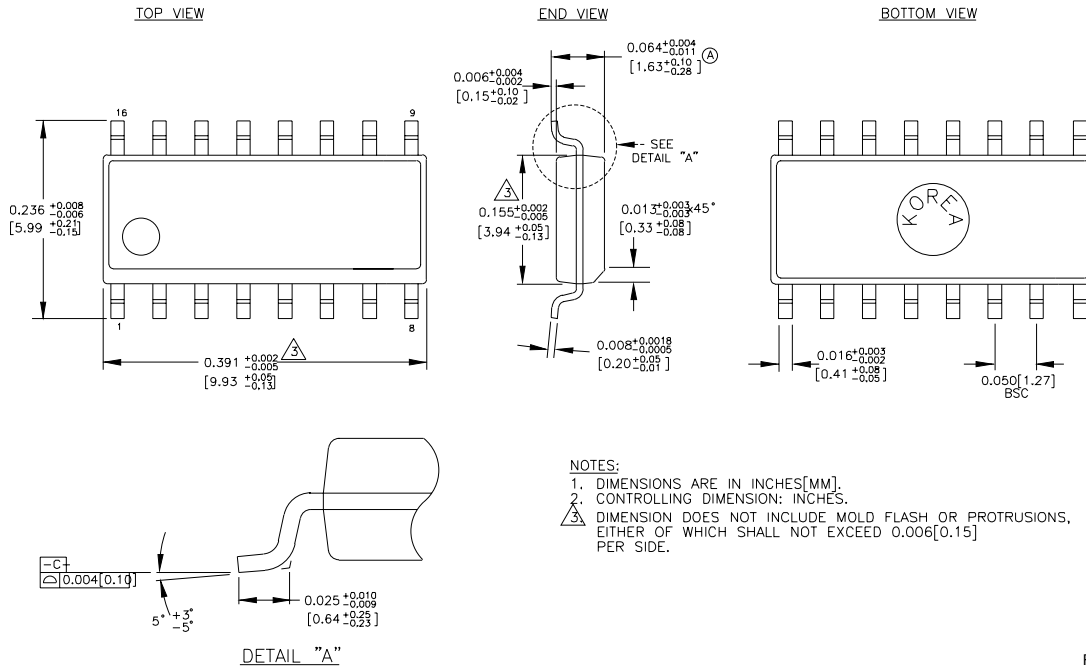

Rev. 02

**MICREL, INC. 2180 FORTUNE DRIVE SAN JOSE, CA 95131 USA**

TEL + 1 (408) 944-0800 FAX + 1 (408) 474-1000 WEB <http://www.micrel.com>

The information furnished by Micrel in this data sheet is believed to be accurate and reliable. However, no responsibility is assumed by Micrel for its use. Micrel reserves the right to change circuitry and specifications at any time without notification to the customer.

Micrel Products are not designed or authorized for use as components in life support appliances, devices or systems where malfunction of a product can reasonably be expected to result in personal injury. Life support devices or systems are devices or systems that (a) are intended for surgical implant into the body or (b) support or sustain life, and whose failure to perform can be reasonably expected to result in a significant injury to the user. A Purchaser's use or sale of Micrel Products for use in life support appliances, devices or systems is at Purchaser's own risk and Purchaser agrees to fully indemnify Micrel for any damages resulting from such use or sale.

© 2006 Micrel, Incorporated.