

4-BIT SINGLE-CHIP MICROCONTROLLER

The μPD17P103 is a tiny microcontrollers consisting of a 1K-byte ROM, 16-word RAM, and 11 input/output ports. It is a one-time PROM version of the μPD17103, whose internal mask ROM is replaced with a one-time PROM.

Two μPD17P103 models are available: μPD17P103CX, which allows a program to be written only once, and μPD17P103GS. They are suitable for evaluation of μPD17103 and for small-scale production.

The μPD17000 architecture of the CPU uses general registers so that data memory can be manipulated directly for effective programming. Every instruction is 1 word long, consisting of 16 bits.

FEATURES

- Compatible with the μPD17103
- Program memory (one-time PROM): 1K bytes (512 words x 16 bits)
- Data memory (RAM): 16 words x 4 bits
- Input/output ports: 11 ports (including three N-ch open-drain outputs)
- Instruction execution time: 2 μs (with 8-MHz crystal or ceramic resonator connected)
- Number of instructions: 24 (Each instruction is 1 word long.)
- Stack level: 1
- A standby function is supported (with the STOP and HALT instructions).
- Data memory can retain data on low voltage (2.0 V at minimum).
- An oscillator is included for the system clock (for crystal or ceramic resonator).
- Operating supply voltage: 2.7 to 6.0 V (at 2 MHz)
4.5 to 6.0 V (at 8 MHz)

APPLICATIONS

- Controlling electric appliances or toys
- Providing general-purpose logic ICs in one chip

ORDERING INFORMATION

Order Code	Package
μPD17P103CX	16-pin plastic DIP (300 mil)
μPD17P103GS	16-pin plastic SOP (300 mil)

PIN CONFIGURATION (Top View)

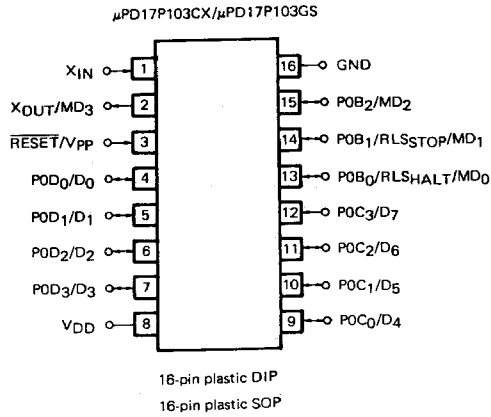

BLOCK DIAGRAM

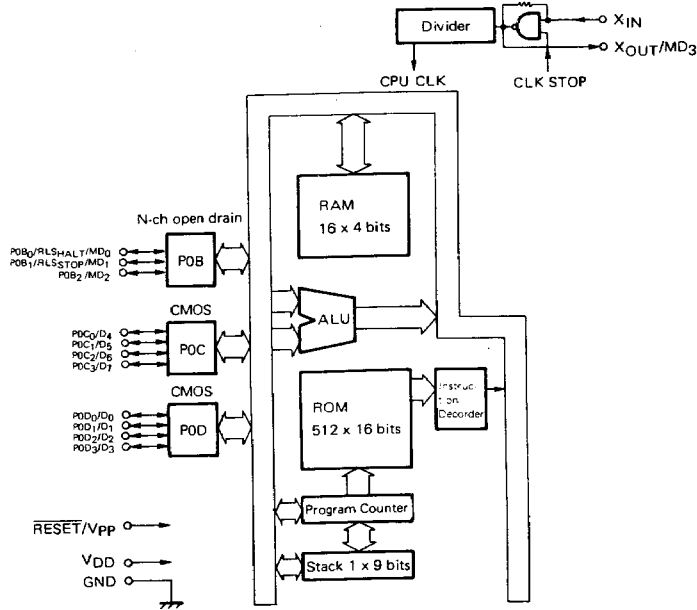

PIN FUNCTIONS

PIN FUNCTIONS

- Port pins

PIN NAME	INPUT/OUTPUT	DUAL FUNCTION PIN		FUNCTION		When writing to program memory or verifying its contents	WHEN RESET
		RLS _{HALT}	MD ₀				
POB ₀	Input/output	RLS _{HALT}	MD ₀	• N-ch open-drain 4-bit input/output port (port 0B)	For the HALT mode releasing	Mode selection pin	High impedance (input mode)
POB ₁		RLS _{STOP}	MD ₁		For the STOP mode releasing		
POB ₂		MD ₂					
POC ₀	Input/output	D ₄		• CMOS (push-pull) 4-bit input/output port (port 0C)		8-bit data input/output pin (high-order 4 bits)	High impedance (input mode)
POC ₁		D ₅					
POC ₂		D ₆					
POC ₃		D ₇					
POD ₀	Input/output	D ₀		• CMOS (push-pull) 4-bit input/output port (port 0D)		8-bit data input/output pin (low-order 4-bits)	High impedance (input mode)
POD ₁		D ₁					
POD ₂		D ₂					
POD ₃		D ₃					

- Non-port pins

PIN NAME	INPUT/OUTPUT	DUAL FUNCTION PIN	FUNCTION	When writing to program memory or verifying its contents
RESET	Input	V _{pp}	System reset input pin	Voltage is applied to this pin (+12.5 V)
V _{DD}			Positive power supply pin	Positive power supply pin (+6.0 V)
GND			GND pin	GND pin
XIN			Pins to be connected to the system clock resonator	Program memory address update
XOUT		MD ₃	Pins to be connected to the system clock resonator	Mode selection pin

PIN INPUT/OUTPUT CIRCUITS

Following are schematics of the input/output circuits of the pins of the μPD17P103.

(1) P0C and P0D

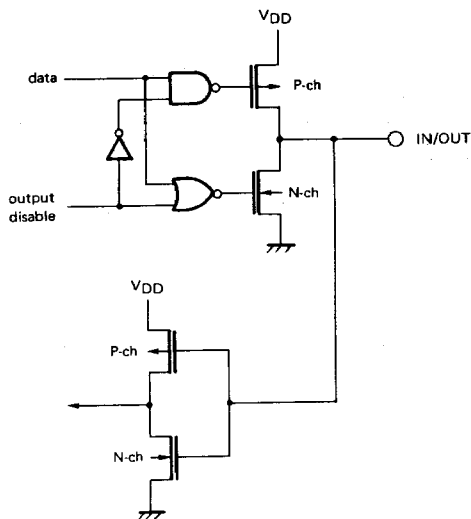

(2) P0B₀ and P0B₁

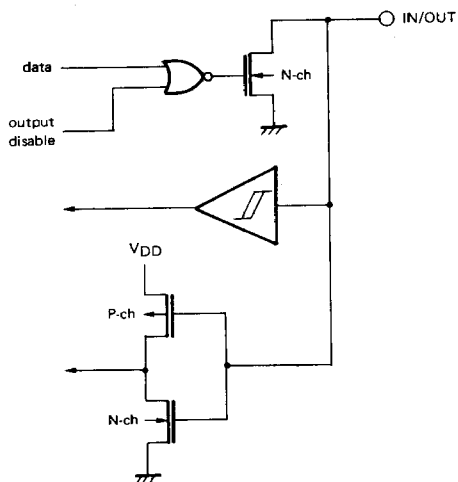

(3) POB₂

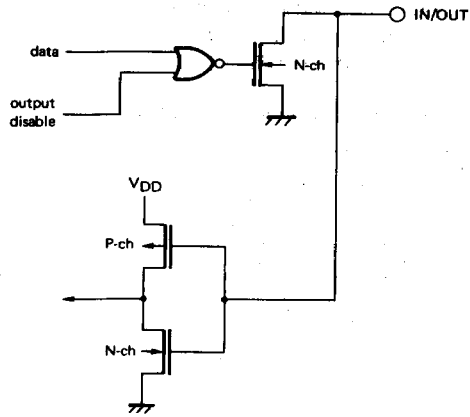

2

(4) $\overline{\text{RESET}}$

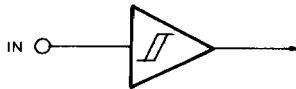

9. DIFFERENCES BETWEEN THE μPD17P103 AND μPD17103

The μPD17P103 is a one-time PROM version of the μPD17103, in which the internal mask ROM is replaced with a one-time PROM. The μPD17P103 has the same CPU functions and internal hardwares as those of μPD17103 except for its program memory and mask option. Table 9-1 lists the differences between them.

Table 9-1 Differences between μPD17P103 and μPD17103

ITEM	μPD17P103	μPD17103
ROM	One-time PROM 512 x 16 bits	Mask ROM 512 x 16 bits
Pull-up resistors of pins POB ₀ to POB ₂	None	Mask option
Pull-up resistors of RESET pin	None	Mask option
Connection pin	V _{PP} pin and operation mode selection pins are provided.	V _{PP} pin and operation mode selection pins are not provided.
Power supply	2.7 to 6.0 V (at 2 MHz) 4.5 to 6.0 V (at 8 MHz)	
Package	16-pin DIP 16-pin SOP	

10. WRITING TO AND VERIFYING ONE-TIME PROM (PROGRAM MEMORY)

The μPD17P103's internal program memory consists of a 512 x 16 bit one-time PROM.

Writing to the one-time PROM or verifying the contents of the PROM is accomplished using the pins shown in the table below. Note that address inputs are not used; instead, the address is updated using the clock input from the X_{IN} pin.

PIN NAME	FUNCTION
V _{PP}	Voltage is applied to this pin when writing to program memory or verifying its contents.
X _{IN}	Input pin for address update clock used when writing to program memory or verifying its contents.
MD ₀ to MD ₃	Pins that turn to input pins and are used as operation mode selection pins when writing to program memory or verifying its contents
D ₀ to D ₇	Input/output pins for 8-bit data used when writing to program memory or verifying its contents

10.1 Program Memory Write/Verify Modes

If +6 V is applied to the V_{DD} pin and +12.5 V is applied to the V_{PP} pin after a certain duration of reset status (V_{DD} = 5 V, RESET = 0 V), the μPD17P103 enters program memory write/verify mode. A specific operating mode is then selected by setting the MD₀ through MD₃ pins as follows. Set the other unused pins to GND level by means of pull-down resistors.

Operating mode specification						Operating mode
V _{PP}	V _{DD}	MD ₀	MD ₁	MD ₂	MD ₃	
+12.5 V	+6 V	H	L	H	L	Program memory address clear mode
		L	H	H	H	Write mode
		L	L	H	H	Verify mode
		H	X	H	H	Program inhibit mode

X: L (low) or H (high)

10.2 Writing to Program Memory

The procedure for writing to program memory is described below: high-speed write is possible.

- (1) Pull low the levels on all unused pins to GND by means of resistors. Bring X_{IN} to low level.
- (2) Apply 5 V to V_{DD} and bring V_{PP} to low level.
- (3) Wait 10 μs. Then apply 5 V to V_{PP}.
- (4) Set the mode selection pins to program memory address clear mode.
- (5) Apply 6 V to V_{DD} and 12.5 V to V_{PP}.
- (6) Select program inhibit mode.
- (7) Write data in 1 ms write mode.
- (8) Select program inhibit mode.
- (9) Select verify mode. If the write operation is found successful, proceed to step (10). If the operation is found unsuccessful, repeat steps (7) to (9).
- (10) Perform additional write for (number of repetitions of steps (7) to (9)) x 1 ms.
- (11) Select program inhibit mode.
- (12) Increment the program memory address by one on reception of four pulses on the X_{IN} pin.

- (13) Repeat steps (7) to (12) until the last address is reached.
- (14) Select program memory address clear mode.
- (15) Apply 5 V to the V_{DD} and V_{pp} pins.
- (16) Turn power off.

The timing for steps (2) to (12) is shown below.

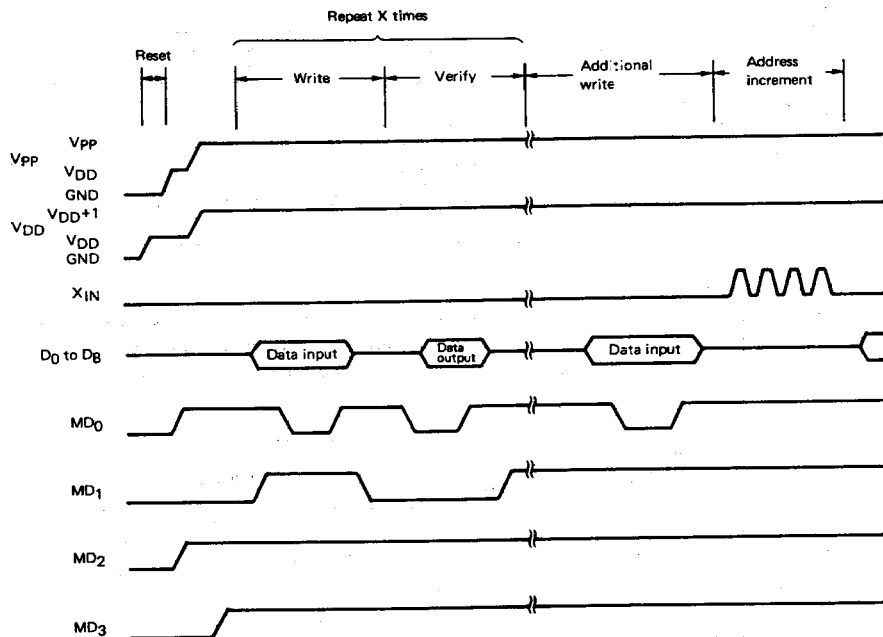

10.3 Reading Program Memory

- (1) Pull low the levels of all unused pins to GND by means of resistors. Bring X_{IN} to low level.
- (2) Apply 5 V to V_{DD} and bring V_{pp} to low level.
- (3) Wait 10 μ s. Then apply 5 V to V_{pp} .
- (4) Set the mode selection pins to program memory address clear mode.
- (5) Apply 6 V to V_{DD} and 12.5 V to V_{pp} .
- (6) Select program inhibit mode.
- (7) Select verify mode. Data is output sequentially one address at a time for each cycle of four clock pulses on the X_{IN} pin.
- (8) Select program inhibit mode.
- (9) Select program memory address clear mode.
- (10) Apply 5 V to the V_{DD} and V_{pp} pins.
- (11) Turn power off.

The timing for steps (2) to (9) is shown below.

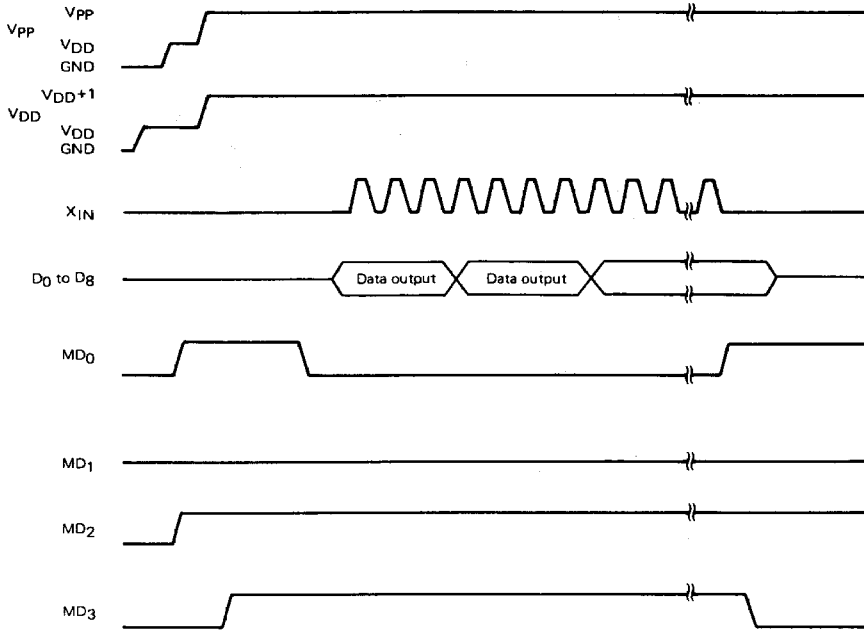

11. RESERVED WORDS

Table 11-1 lists the reserved words defined in the μPD17P103 device file (AS17103).

Table 11-1 Reserved Words

Name	Attribute	Value	Read/write	Description
POB0	FLG	0.71H.0	Read/write	Bit 0 of port 0B
POB1	FLG	0.71H.1	Read/write	Bit 1 of port 0B
POB2	FLG	0.71H.2	Read/write	Bit 2 of port 0B
*POB3	FLG	0.71H.3	Read	Always set to 0
POC0	FLG	0.72H.0	Read/write	Bit 0 of port 0C
POC1	FLG	0.72H.1	Read/write	Bit 1 of port 0C
POC2	FLG	0.72H.2	Read/write	Bit 2 of port 0C
POC3	FLG	0.72H.3	Read/write	Bit 3 of port 0C
POD0	FLG	0.73H.0	Read/write	Bit 0 of port 0D
POD1	FLG	0.73H.1	Read/write	Bit 1 of port 0D
POD2	FLG	0.73H.2	Read/write	Bit 2 of port 0D
POD3	FLG	0.73H.3	Read/write	Bit 3 of port 0D
BCD	FLG	0.7EH.0	Read/write	BCD arithmetic flag
PSW	MEM	0.7FH	Read/write	Program status word
Z	FLG	0.7FH.1	Read/write	Zero flag
CY	FLG	0.7FH.2	Read/write	Carry flag
CMP	FLG	0.7FH.3	Read/write	Compare flag

* Although POB3 does not exist in the μPD17P103, it is defined as a ready-only flag so that it is treated as a dummy bit when a built-in macro is used.

12. INSTRUCTION SET

12.1 Instruction Set List

b ₁₄ -b ₁₁		b ₁₅		0		1	
		BIN	HEX				
0 0 0 0	0	ADD	r, m	ADD	m, #i		
0 0 0 1	1	SUB	r, m	SUB	m, #i		
0 0 1 0	2	ADDC	r, m	ADDC	m, #i		
0 0 1 1	3	SUBC	r, m	SUBC	m, #i		
0 1 0 0	4	AND	r, m	AND	m, #i		
0 1 0 1	5	XOR	r, m	XOR	m, #i		
0 1 1 0	6	OR	r, m	OR	m, #i		
0 1 1 1	7	RET					
		RETSK					
		RORC	r				
		STOP	s				
		HALT	h				
		NOP					
1 0 0 0	8	LD	r, m	ST	m, r		
1 0 0 1	9	SKE	m, #i	SKGE	m, #i		
1 0 1 0	A						
1 0 1 1	B	SKNE	m, #i	SKLT	m, #i		
1 1 0 0	C	BR	addr	CALL	addr		
1 1 0 1	D			MOV	m, #i		
1 1 1 0	E			SKT	m, #n		
1 1 1 1	F			SKF	m, #n		

12.2 INSTRUCTIONS LIST

Legend:

- M : One of data memory
- m : Data memory address specified by [m_H, m_L] of each bank
- m_H : Data memory address high (row address) ; 3 bits
- m_L : Data memory address low (column address) ; 4 bits
- R : One of general register specified by [(RP), r]
- r : General register address low (column address) ; 4 bits
- RP : General register pointer
- PC : Program counter
- SP : Stack pointer
- STACK : Stack specified by (SP)
- i : Immediate data ; 4 bits
- n : Bit position ; 4 bits
- addr : One of program memory address ; 11 bits
- a_H : Program memory address high ; 3 bits
- a_M : Program memory address middle ; 4 bits
- a_L : Program memory address low ; 4 bits
- CY : Carry flag
- CMP : Compare flag
- s : Stop release condition
- h : Halt release condition
- { } : Address of M,R
- () : Contents of M,R

Type	Mnemonic	Operand	Function	Operation	Machine code			
					Op code	3 bits	4 bits	4 bits
Add	ADD	r,m	Add memory to register	R← (R) + (M)	0000	m _H	m _L	r
		m,#i	Add immediate data to memory	M← (M) + i	1000	m _H	m _L	i
	ADDC	r,m	Add memory to register with carry	R← (R) + (M) + (CY)	0010	m _H	m _L	r
		m,#i	Add immediate data to memory with carry	R← (M) + i + (CY)	1010	m _H	m _L	i
Subtract	SUB	r,m	Subtract memory from register	R← (R) - (M)	0001	m _H	m _L	r
		m,#i	Subtract immediate data from memory	M← (M) - i	1001	m _H	m _L	i
	SUBC	r,m	Subtract memory from register with borrow	R← (R) - (M) - (CY)	0011	m _H	m _L	r
		m,#i	Subtract immediate data from memory with borrow	M← (M) - i - (CY)	1011	m _H	m _L	i
Compare	SKE	m,#i	Skip if memory equal to immediate data	M-i, skip if zero	0100	m _H	m _L	i
	SKGE	m,#i	Skip if memory greater than or equal to immediate data	M-i, skip if not borrow	1100	m _H	m _L	i
	SKLT	m,#i	Skip if memory less than immediate data	M-i, skip if borrow	1101	m _H	m _L	i
	SKNE	m,#i	Skip if memory not equal to immediate data	M-i, skip if not zero	0101	m _H	m _L	i
Logical operation	AND	m,#i	Logical AND of memory and immediate data	M← (M) AND i	1010	m _H	m _L	i
		r,m	Logical AND of register and memory	R← (R) AND (M)	0010	m _H	m _L	r
	OR	m,#i	Logical OR of memory and immediate data	M← (M) OR i	1010	m _H	m _L	i
		r,m	Logical OR of register and memory	R← (R) OR (M)	0010	m _H	m _L	r
XOR	m,#i	Logical XOR of memory and immediate data	M← (M) XOR i	1001	m _H	m _L	i	
	r,m	Logical XOR of register and memory	R← (R) XOR (M)	0001	m _H	m _L	r	
Transfer	LD	r,m	Load memory to register	R← (M)	0100	m _H	m _L	r
	ST	m,r	Store register to memory	(M)←R	1100	m _H	m _L	r
	MOV	m,#i	Move immediate data to memory	M← i	1101	m _H	m _L	i
Test	SKT	m,#n	Test memory bits, then skip if all bits specified are true	CMP ← 0 skip if M _n = all "1"	1110	m _H	m _L	n
	SKF	m,#n	Test memory bits, then skip if all bits specified are false	CMP ← 0 skip if M _n = all "0"	1111	m _H	m _L	n

Type	Mnemonic	Operand	Function	Operation	Machine code			
					Op code	3 bits	4 bits	4 bits
Branch	BR	addr	Jump to the address	PC←ADDR	01100	a _M	a _M	a _L
Shift	RORC	r	Rotate register right with carry	(CY)→(R)→CY	00111	000	0111	r
Subroutine	CALL	addr	Call subroutine	SP←(SP)−1 STACK←((PC)+1), PC←ADDR	11100	a _M	a _M	a _L
	RET		Return to main routine from subroutine	PC←(STACK). SP←(SP)+1	00111	000	1110	0000
	RETSK		Return to main routine from subroutine, then skip unconditionally	PC←(STACK). SP←(SP)+1 and skip	00111	001	1110	0000
Miscellaneous	STOP	s	Stop clock	STOP	00111	010	1111	s
	HALT	h	Halt the CPU, restart by condition h	HALT	00111	011	1111	h
	NOP		No operation	No Operation	00111	100	1111	0000

2

13. ELECTRICAL CHARACTERISTICS

ABSOLUTE MAXIMUM RATINGS (T_a = 25 °C)

Supply Voltage	V _{DD}		-0.3 to +7.0	V
Supply Voltage	V _{PP}		-0.3 to +13.5	V
Input Voltage	V _I	POC, POD	-0.3 to V _{DD} +0.3	V
		POB	-0.3 to +11	V
Output Voltage	V _O	POC, POD	-0.3 to V _{DD} +0.3	V
		POB	-0.3 to +11	V
High-Level Output Current	I _{OH}	Each of POB, POC, POD	-5	mA
		Total of all pins	-15	mA
Low-Level Output Current	I _{OL}	Each of POB, POC, POD	30	mA
		Total of all pins	100	mA
Operating Temperature	T _{opt}		-40 to +85	°C
Storage Temperature	T _{stg}		-65 to +150	°C
Power Consumption	P _d	T _a = 85 °C	400	mW
		16-pin DIP 16-pin SOP	190	

CAPACITANCE (T_a = 25 °C, V_{DD} = 0 V)

CHARACTERISTICS	SYMBOL	MIN.	TYP.	MAX.	UNIT	CONDITIONS
Input Capacitance	C _{IN}			15	pF	f=1 MHz
I/O(*) Capacitance	C _{IO}			15	pF	0 V for pins other than pins to be measured

*: input/output

DC CHARACTERISTICS (T_a = -40 to +85 °C, V_{DD} = 2.7 to 6.0 V)

CHARACTERISTICS	SYMBOL	MIN.	TYP.	MAX.	UNIT	CONDITION	
High-Level Input Voltage	V _{IH1}	0.7 V _{DD}		V _{DD}	V	Other than the following pins and port	
	V _{IH2}	0.8 V _{DD}		V _{DD}	V	POB and RESET	
	V _{IH3}	0.8 V _{DD}		9	V	POB (*)	
	V _{IH4}	V _{DD} -0.5		V _{DD}	V	X _{IN}	
Low-Level Input Voltage	V _{IL1}	0		0.3 V _{DD}	V	Other than the following pins and port	
	V _{IL2}	0		0.2 V _{DD}	V	POB and RESET	
	V _{IL3}	0		0.5	V	X _{IN}	
High-Level Output Voltage on POC and POD	V _{OH}	V _{DD} -2.0			V	V _{DD} =4.5 to 6.0 V, I _{OH} =-2 mA	
		V _{DD} -1.0			V	I _{OH} =-200 μA	
Low-Level Output Voltage on POB, POC, and POD	V _{OL}			2.0	V	V _{DD} =4.5 to 6.0 V, I _{OL} =15 mA	
				0.5	V	I _{OL} =600 μA	
High-Level Input Leakage Current on POB, POC, and POD	I _{LIH1}			5	μA	V _{IN} =V _{DD}	
				10	μA	V _{IN} =9 V (*)	
Low-Level Input Leakage Current on POB, POC, and POD	I _{LIL}			-5	μA	V _{IN} =0 V	
High-Level Output Leakage Current on POB, POC, and POD	I _{LOH1}			5	μA	V _{OUT} =V _{DD}	
				10	μA	V _{OUT} =9 V (*)	
Low-Level Output Leakage Current on POB, POC, and POD	I _{LOL}			-5	μA	V _{OUT} =0 V	
Power Supply Current	I _{DD1}		1.5	4.5	mA	Operation mode	V _{DD} =5.0 V ±10 %, f _{CC} =8.0 MHz
			250	750	μA		V _{DD} =3.0 V ±10 %, f _{CC} =2.0 MHz
	I _{DD2}		1.0	3.0	mA	HALT mode	V _{DD} =5.0 V ±10 %, f _{CC} =8.0 MHz
			200	600	μA		V _{DD} =3.0 V ±10 %, f _{CC} =2.0 MHz
	I _{DD3}		0.1	10	μA	STOP mode	V _{DD} =5.0 V ±10 %, f _{CC} =8.0 MHz
			0.1	5	μA		V _{DD} =3.0 V ±10 %

*: When N-ch open-drain input/output is selected.

μPD17P103

CHARACTERISTICS OF DATA MEMORY FOR HOLDING DATA ON LOW SUPPLY VOLTAGE IN THE STOP MODE ($T_a = -40$ to $+85$ °C)

CHARACTERISTICS	SYMBOL	MIN.	TYP.	MAX.	UNIT	CONDITION
Data Hold Supply Voltage	V _{DDDR}	2.0		6.0	V	
Data Hold Supply Current	I _{DDDR}		0.1	5.0	μA	V _{DDDR} = 2.0 V
Release Signal Set Time	t _{SREL}	0			μs	

AC CHARACTERISTICS ($T_a = -40$ to $+85$ °C, V_{DD} = 2.7 to 6.0 V)

CHARACTERISTICS	SYMBOL	MIN.	TYP.	MAX.	UNIT	CONDITION
Internal Clock Cycle Time	T _{CY}	1.9		33	μs	V _{DD} = 4.5 to 6.0 V
		7.6		33	μs	
High/Low Level Width on P0B ₀ and P0B ₁	T _{PBH} T _{PBL}	10			μs	
High/Low Level Width on $\overline{\text{RESET}}$	T _{RSH} T _{RSL}	10			μs	

DC PROGRAMING CHARACTERISTICS

($T_a = 25$ °C, V_{DD} = 6.0 ± 0.25 V, V_{pp} = 12.5 ± 0.5 V)

CHARACTERISTICS	SYMBOL	MIN.	TYP.	MAX.	UNIT	CONDITION
Input Voltage High	V _{IH1}	0.7·V _{DD}		V _{DD}	V	Except X _{IN}
	V _{IH2}	V _{DD} -0.5		V _{DD}	V	X _{IN}
Input Voltage Low	V _{IL1}	0		0.3 V _{DD}	V	Except X _{IN}
	V _{IL2}	0		0.4	V	X _{IN}
Input Leakage Current	I _{LI}			10	μA	V _{IN} = V _{IL} or V _{IH}
Output Voltage High	V _{OH}	V _{DD} -1.0			V	I _{OH} = -1 mA
Output Voltage Low	V _{OL}			0.4	V	I _{OL} = 1.6 mA
V _{DD} Power Supply Current	I _{DD}			30	mA	
V _{pp} Power Supply Current	I _{pp}			30	mA	MD0 = V _{IL} , MD1 = V _{IH}

Notes 1: V_{pp} must be under +13.5 V including overshoot.

2: V_{DD} must be applied before V_{pp} on and must be off after V_{pp} off.

AC PROGRAMMING CHARACTERISTICS (T_a = 25 °C, V_{DD} = 6.0 ±0.25 V, V_{PP} = 12.5 ±0.5 V)

CHARACTERISTICS	SYMBOL	*1	MIN.	TYP.	MAX.	UNIT	CONDITION
Address Set Up Time(*2) to MD0 ↓	t _{AS}	t _{AS}	2			μs	
MD1 Setup Time to MD0 ↓	t _{M1S}	t _{OES}	2			μs	
Data Setup Time to MD0 ↓	t _{DS}	t _{DS}	2			μs	
Address Hold Time(*2) to MD0 ↑	t _{AH}	t _{AH}	2			μs	
Data Hold Time to MD0 ↑	t _{DH}	t _{DH}	2			μs	
Data Output Float Delay Time From MD0 ↑→	t _{DF}	t _{DF}	0		130	ns	
V _{pp} Setup Time to MD3 ↑	t _{VPS}	t _{VPS}	2			μs	
V _{DD} Setup Time to MD3 ↑	t _{VDS}	t _{VCS}	2			μs	
Initial Program Pulse Width	t _{PW}	t _{PW}	0.95	1.0	1.05	ms	
Additional Program Pulse Width	t _{OPW}	t _{OPW}	0.95		21.0	ms	
MD0 Setup Time to MD1 ↑	t _{MOS}	t _{CES}	2			μs	
Data Output Delay Time From MD0 ↓→	t _{DV}	t _{DV}			1	μs	MD0 = MD1 = V _{IL}
MD1 Hold Time to MD0 ↑	t _{M1H}	t _{OEH}	2			μs	t _{M1H} + t _{M1R} ≥ 50 μs
MD1 Recovery Time to MD0 ↓	t _{M1R}	t _{OR}	2			μs	
Program Counter Reset Time	t _{PCR}	—	10			μs	
X _{IN} Input High, Low Level Range	t _{XH} , t _{XL}	—	0.125			μs	
X _{IN} Input Frequency	f _X	—			4.19	MHz	
Initial Mode Set Time	t _I	—	2			μs	
MD3 Setup Time to MD1 ↑	t _{M3S}	—	2			μs	
MD3 Hold Time to MD1 ↓	t _{M3H}	—	2			μs	
MD3 Setup Time to MD0 ↓	t _{M3SR}	—	2			μs	Read program memory
Data Output Delay Time From Address(*2)	t _{DAD}	t _{ACC}	2			μs	Read program memory
Data Output Hold Time From Address(*2)	t _{HAD}	t _{OH}	0		130	ns	Read program memory
MD3 Hold Time to MD0 ↑	t _{M3HR}	—	2			μs	Read program memory
Data Output Float Delay Time From MD3 ↓→	t _{DFR}	—	2			μs	Read program memory
Reset Setup Time	t _{RES}		10			μs	

*1: Symbols for corresponding μPD27C256.

*2: Internal address signal is incremented by one at the falling edge of the third X_{IN} input, and it is not connected to the pin.

Write program memory timing

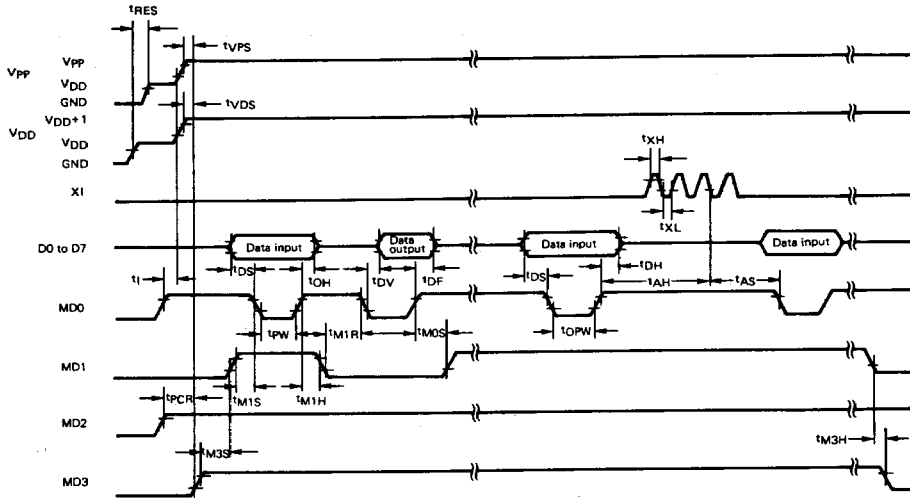

Read program memory timing

