

General Description

The AAT4625 SmartSwitch is part of AnalogicTech's Application Specific Power MOSFET™ (ASPM™) product family. It is a 1.0A current limited P-channel MOSFET power switch designed for high-side load-switching applications. This switch operates with inputs ranging from 2.7V to 5.5V, making it ideal for both 3V and 5V systems. An integrated current-limiting circuit protects the input supply against large changes in load current which may cause the supply to fall out of regulation. The AAT4625 is also protected from thermal overload which limits power dissipation and junction temperatures. The current limit threshold is factory programmed at 1.5A, with a maximum of 2.0A. The quiescent supply current is typically a low 16 μ A. In shutdown mode, the supply current decreases to less than 1 μ A.

The AAT4625 is available in Pb-free, 8-pin SOP, TSSOP, or MSOP packages, and is specified over the -40°C to +85°C temperature range.

The AAT4600 series is a family of adjustable and fixed SmartSwitch products with a range of current handling capabilities. Single versions with adjustable current limit (AAT4601) or fixed current limit (AAT4625) as well as dual versions with fixed current limit (AAT4626) are available.

Features

- Compliant with USB 1.1 and 2.0 Specifications
- 2.7V to 5.5V Input Voltage Range
- 1.0A Minimum Continuous Current
- 2.0A Maximum Current Limit
- 60m Ω Typical $R_{DS(ON)}$
- Low Quiescent Current:
 - Typically 16 μ A
 - 1 μ A Maximum with Switch Off
- Thermal Shutdown
- Slew Rate Limited Turn On
- Fault Flag with 10ms Blanking
- Under-Voltage Lockout (UVLO)
- Temperature Range: -40°C to +85°C
- UL Approved—File No. E217765
- 8-Pin SOP, TSSOP, or MSOP Package

Applications

- General Purpose Power Switching
- Hot Swap Supplies
- Notebook Computers
- USB Ports and Peripherals



UL Recognized Component

Typical Application

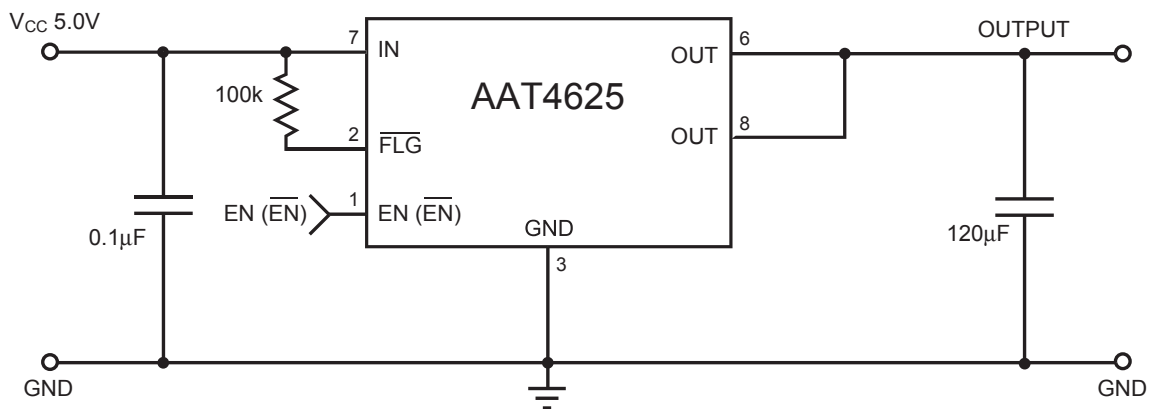

Pin Descriptions

Pin #	Symbol	Function
1	EN ($\overline{\text{EN}}$)	Enable input: logic-compatible enable input. High input > 2.1V typical. Low input < 1.9V typical. Active high or active low option available; see Ordering Information for details.
2	$\overline{\text{FLG}}$	Fault flag output: active-low, open-drain output. Indicates over-current, UVLO, and thermal shutdown.
3	GND	Ground.
4,5	NC	Not internally connected.
6,8	OUT	Switch output: These pins are the P-channel MOSFET drain connection.
7	IN	Supply input: This pin is the P-channel MOSFET source connection. Also supplies the IC's internal circuitry.

Pin Configuration

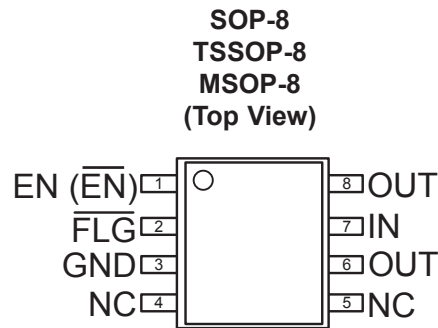

Absolute Maximum Ratings¹

$T_A = 25^\circ\text{C}$, unless otherwise noted.

Symbol	Description	Value	Units
V_{IN}	IN to GND	-0.3 to 6	V
V_{FLG}	FLG to GND	-0.3 to 6	V
I_{FLG}	FLG Current	50	mA
V_{OUT}	OUT to GND	-0.3 to $V_{IN} + 0.3$	V
I_{OUT}	Output Current (Internally Limited)	2.0	A
V_{EN}	EN to GND	-0.3 to 6	V
T_S	Storage Temperature	150	$^\circ\text{C}$
T_{LEAD}	Maximum Soldering Temperature (at Leads)	300	$^\circ\text{C}$

Thermal Information²

Symbol	Description		Value	Units
Θ_{JA}	Maximum Thermal Resistance	SOP-8	120	$^\circ\text{C}/\text{W}$
		TSSOP-8	150	
		MSOP-8	150	
P_D	Maximum Power Dissipation	SOP-8	1.0	W
		TSSOP-8	833	mW
		MSOP-8	833	

1. Stresses above those listed in Absolute Maximum Ratings may cause permanent damage to the device. Functional operation at conditions other than the operating conditions specified is not implied. Only one Absolute Maximum Rating should be applied at any one time.
2. Mounted on an FR4 printed circuit board.

Electrical Characteristics

$V_{IN} = 5V$, $T_A = -40^{\circ}C$ to $+85^{\circ}C$, unless otherwise noted. Typical values are $T_A = 25^{\circ}C$; **bold** values designate full temperature range.

Symbol	Description	Conditions	Min	Typ	Max	Units
V_{IN}	Operation Voltage		2.7		5.5	V
I_Q	Quiescent Current	$V_{IN} = 5V$, EN = Active		16	30	μA
$I_{Q(OFF)}$	Off Supply Current	$V_{IN} = 5.5V$, EN (EN) = Inactive			1	μA
$V_{EN-THRS}$	Enable Input Threshold	Low-to-High Transition			2.4	V
		High-to-Low Transition	0.8			
I_{EN}	Enable Input Current	$V_{EN} = 0V$ to $5.5V$		0.01	1	μA
C_{EN}	Enable Input Capacitance			1		pF
$R_{DS(ON)}$	On-Resistance	$V_{IN} = 5V$, $T_A = 25^{\circ}C$		60	100	m Ω
		$V_{IN} = 3.0V$, $T_A = 25^{\circ}C$		70	115	
T_{ON}	Output Turn-On Delay	$V_{IN} = 5V$, $R_L = 10\Omega$		0.25		ms
$T_{ON-RISE}$	Output Turn-On Rise Time	$V_{IN} = 5V$, $R_L = 10\Omega$		0.2		ms
T_{OFF}	Output Turn-Off Delay	$V_{IN} = 5V$, $R_L = 10\Omega$		5	20	μs
$T_{OFF-FALL}$	Output Turn-Off Fall Time	$V_{IN} = 5V$, $R_L = 10\Omega$			20	μs
$I_{SD(OFF)}$	Output Leakage Current	EN = Inactive, $V_{IN} = 5.5V$, $V_{OUT} = 0V$		0.03	15	μA
I_{LIMIT}	Current Limit Threshold	Ramped Load Applied to Enable Output, $V_{OUT} < 4.0V$	1.0	1.5	2.0	A
OTMP	Over-Temperature Shutdown	T_J Increasing		125		$^{\circ}C$
		T_J Decreasing		115		
R_{FLG}	Error Flag Output Resistance	$V_{IN} = 5V$, $I_L = 1mA$		30		Ω
I_{SINK}	Error Flag Off Current	$V_{FLG} = 5.5V$		0.05	1	μA
V_{UVLO}	Under-Voltage Lockout	$V_{IN} =$ Increasing, 1% Hysteresis	2.0	2.3	2.7	V
T_{BLANK}	FAULT Blanking			10		ms

Typical Characteristics

$V_{IN} = 5V$, $T_A = 25^\circ C$, unless otherwise noted.

Quiescent Current vs. Temperature

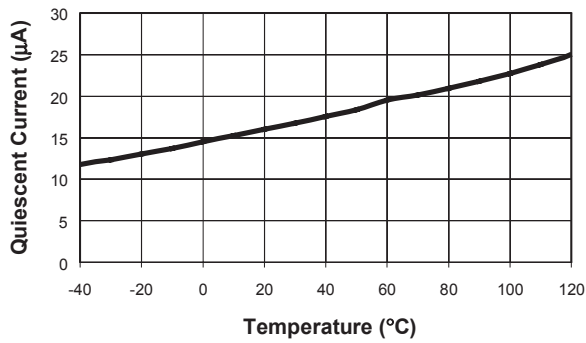

Quiescent Current

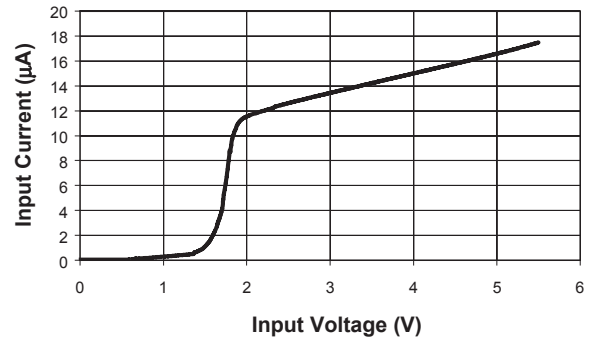

Current Limit

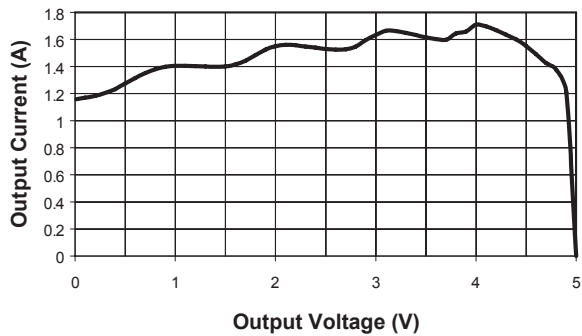

Off-Supply Current vs. Temperature

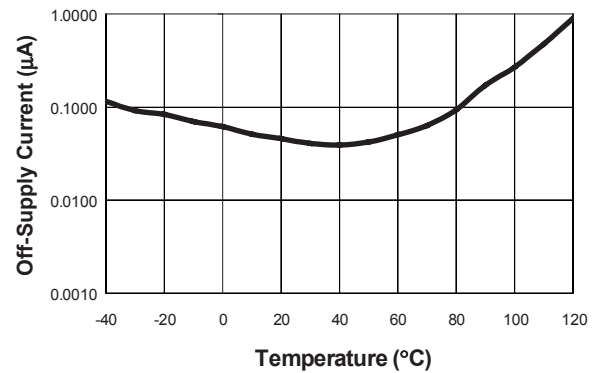

Off-Switch Current vs. Temperature

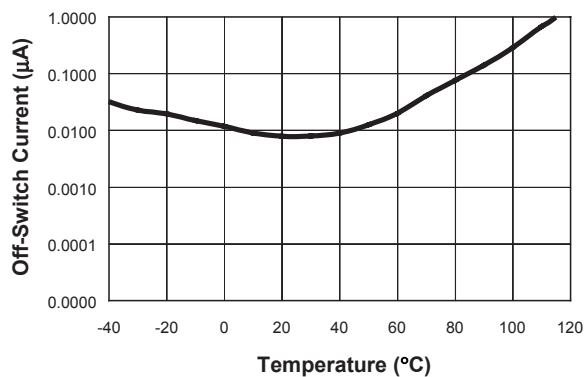

Turn On/Off Response with 10Ω 1µF Load

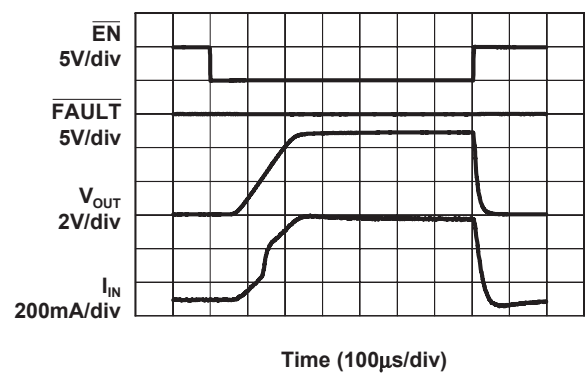

Typical Characteristics

$V_{IN} = 5V$, $T_A = 25^\circ C$, unless otherwise noted.

Start Into 1Ω Load

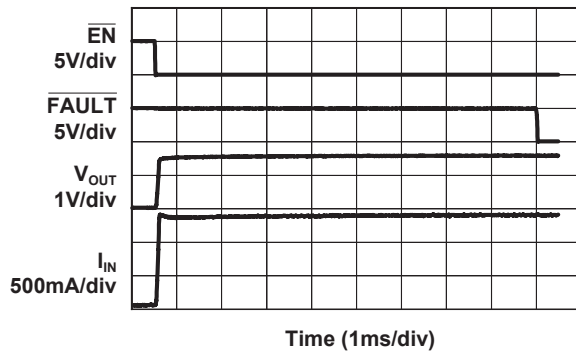

Thermal Shutdown Response

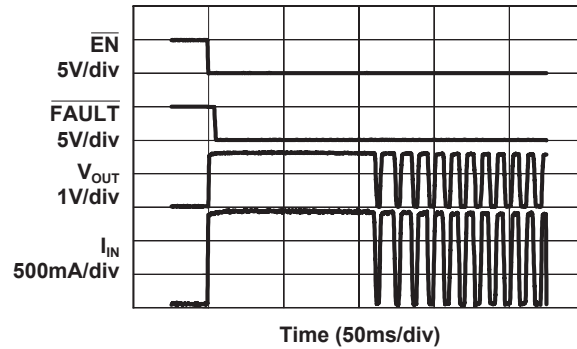

Short-Circuit Through 0.3Ω

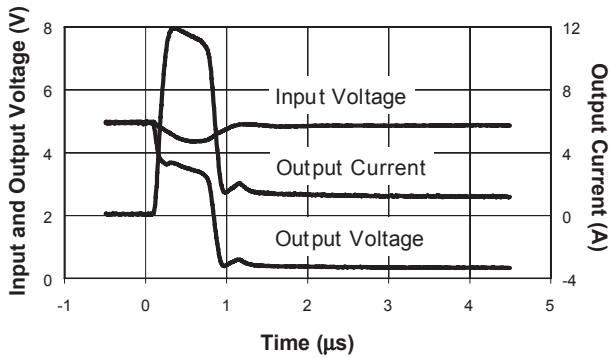

Short-Circuit Through 0.6Ω

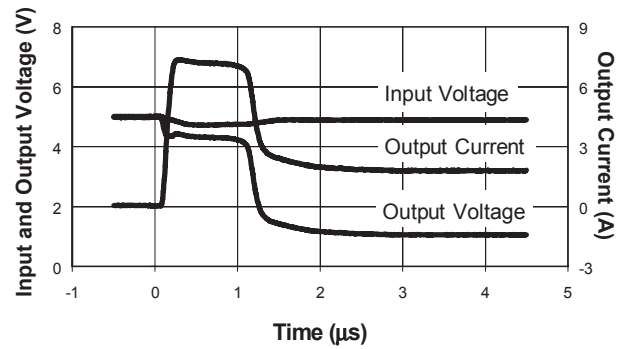

$R_{DS(ON)}$ vs. Temperature

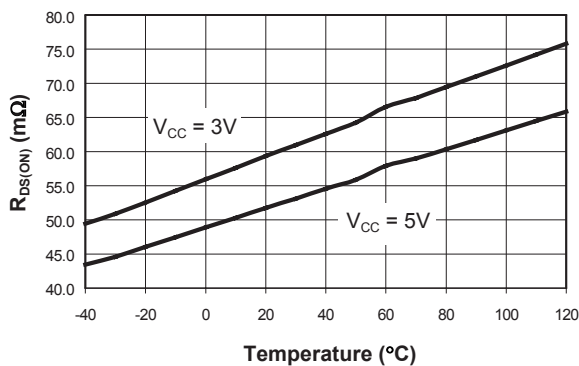

Functional Block Diagram

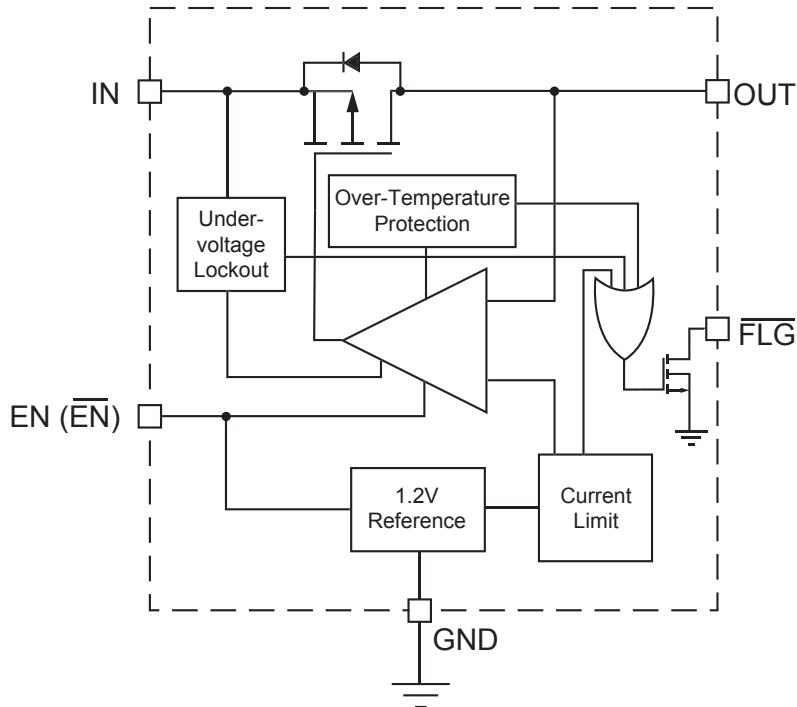

Functional Description

The AAT4625 is an integrated MOSFET load switch with a fixed current limit, over-temperature protection, level shifted input, and a fault flag. The current limit control is combined with an over-temperature thermal limit circuit to provide a comprehensive system to protect the load switch under short-circuit or other adverse operating conditions. The AAT4625 is ideally suited for control and protection of peripheral ports such as USB, RS232, and parallel ports.

The current limit and over-temperature circuits will act independently. The device current limit is activated when the output load current exceeds a preset internal threshold level. The minimum current limit threshold characteristic is specified by $I_{LIM(MIN)}$. If the load switch ambient temperature becomes excessive or if a short-circuit condition persists, the die temperature will rise, causing the over-temperature protection circuit to activate.

If the current limit or over-temperature protection circuits are active for more than two milliseconds, the system will be informed via the FAULT flag. A 10ms fault blanking delay allows the AAT4625 to be turned on into large capacitive loads without activating the FAULT flag. The open drain FAULT output can be connected directly to system controllers driven by voltage levels less than the IN pin voltage without additional level shifting circuitry.

The load switch is turned on and off by applying a logic level signal to the EN pin. The AAT4625 enable function is available in both active high and active low logic level versions. The AAT4625 typically consumes 16µA when operating; when off, the device draws less than 1µA. In the off state, current is prevented from flowing between the input and output. The EN function has logic level thresholds that allow the AAT4625 to be TTL compatible and may also be controlled by 2.5V to 5.0V CMOS circuits. The voltage level on either EN or FAULT should not exceed the input supply level present on the IN pin.

Applications Information

Operation in Current Limit

If an excessive load is applied to the output of an AAT4625, the load current will be limited by the device's current limit circuitry. Refer to the "Current Limit" curve in the Typical Characteristics section of this datasheet. If a short circuit were to occur on the load, there would be a demand for more current than what is allowed by the internal current limiting circuit and the voltage at the device output will drop. This causes the AAT4625 to dissipate more power than in normal operation, causing the die temperature to increase. When die temperature exceeds the internal over-temperature threshold, the AAT4625 will shut down. After shutting down, the AAT4625 cools to a level below the over-temperature threshold, at which point it will start up again. The AAT4625 will continue to cycle off and on until one of the following events occurs: the load current is reduced to a level below the AAT4625's current limit setting; the input power is removed; or the output is turned off by a logic high level applied to the EN pin.

Thermal Considerations

Since the AAT4625 has internal current limit and over-temperature protection, junction temperature is rarely a concern. If an application requires a large load current in a high-temperature operating environment, there is the possibility that the over-temperature protection circuit (rather than the current limit circuit) will regulate the current available to the load. In these applications, the maximum current available without risk of activation of the over-temperature circuit can be calculated. The maximum internal temperature while current limit is not active can be calculated using Equation 1:

$$\text{Eq. 1: } T_{J(\text{MAX})} = I_{\text{MAX}}^2 \times R_{\text{DS(ON)(MAX)}} \times R_{\theta\text{JA}} + T_{\text{A(MAX)}}$$

In Equation 1, I_{MAX} is the maximum current required by the load. $R_{\text{DS(ON)(MAX)}}$ is the maximum rated $R_{\text{DS(ON)}}$ of the AAT4625 at high temperature. $R_{\theta\text{JA}}$ is the thermal resistance between the device die and the board onto which it is mounted. $T_{\text{A(MAX)}}$ is the maximum ambient temperature for the print-

ed circuit board assembly under the AAT4625 when the load switch is not dissipating power. Equation 1 can be transformed to provide I_{MAX} ; Refer to Equation 2.

$$\text{Eq. 2: } I_{\text{MAX}} = \sqrt{\frac{T_{\text{SD(MIN)}} - T_{\text{A(MAX)}}}{R_{\text{DS(ON)(MAX)}} \cdot R_{\theta\text{JA}}}}$$

$T_{\text{SD(MIN)}}$ is the minimum temperature required to activate the device over-temperature protection. The typical thermal limit temperature specification is 125°C for the AAT4625; for calculations, 115°C is a safe minimum value to use.

For example, a portable device is specified to operate in a 50°C environment. The printed circuit board assembly will operate at temperatures as high as 85°C. This portable device has a sealed case and the area of the printed board assembly is relatively small, causing $R_{\theta\text{JA}}$ to be approximately 120°C/W. Using Equation 2,

$$I_{\text{MAX}} = \sqrt{\frac{115 - 85}{130 \cdot 120}} = 1.4\text{A}$$

If this system requires less than 1.4A, the thermal limit will not activate during normal operation.

Input Capacitor

The input capacitor serves two purposes. First, it protects the source power supply from transient current effects generated by the application load circuit. If a short circuit is suddenly applied to the output of an AAT4625, there is a microsecond long period during which a large current can flow before the current limit circuit becomes active. Refer to the characteristic curve "Short Circuit Through 0.3Ω." A properly sized input capacitor can dramatically reduce the load switch input transient response effects seen by the power supply and other circuitry upstream from the AAT4625.

The second purpose of the input capacitor is to prevent transient events generated by the load circuit from affecting the operation of the AAT4625. For example, if an AAT4625 is used in a circuit that operates from a 5V power supply with poor step load response, turning on the load switch could cause the

input power supply to drop below the AAT4625's under-voltage lockout threshold. This drop in voltage would cause the AAT4625 to turn off until the input power supply voltage level recovers. Since this cycle would be self-perpetuating, the entire circuit could be seen to be unstable. In the very rare case where capacitor cost is prohibitive and the input capacitor is omitted, the output load circuit should be slew rate limited when turned on.

Output Capacitor

In order to insure stability while the device current limit is active, a small capacitance of approximately 1 μ F should be used. When the AAT4625 is activated using the ON function, there are no momentary current transients, as in the case when a short circuit is suddenly applied to a device that is already on. Refer to the "Turn-On/Off Response" characteristics curve. Regardless of output capacitor size, output current is limited to the value allowed by the threshold determined by the internal current limiting circuitry. Refer to the internal current limit threshold specifications stated in the Electrical Characteristics section of this datasheet. This permits very large output capacitors to be used.

For example, USB ports are specified to have at least 120 μ F of downstream capacitance from their controlling power switch. An output capacitance as large as 1000 μ F would not disturb the input power supply to an AAT4625 used to control a USB port.

EN Input

The AAT4625 is available in both active high and active low enable versions. For specific part numbers, refer to the Ordering Information section of this

datasheet. When the AAT4625 is in the off state, the output is an open circuit and the device quiescent current consumption is reduced to less than 1 μ A. The EN threshold voltage is set to allow the AAT4625 to be controlled by 5V TTL levels, as well as CMOS-compatible levels ranging from 2.5V to 5V. The EN function control voltage level should not exceed the input supply level applied to the IN pin.

Fault Flag Output

The AAT4625 features an active low fault flag output. The fault flag is provided to alert the system if the over-current or over-temperature circuits become active or if the load switch is not receiving a sufficient voltage level to properly operate. If either the current limit or over-temperature circuits in any combination are constantly active for more than approximately 10ms, the FAULT pin is pulled to ground internally through an open drain device. The 10ms delay on the FAULT function is intended to prevent capacitive loads connected to the load switch output from activating the FAULT flag when the device is turned on. The placement of a pull-up resistor between the FAULT pin and the IN pin is recommended. Reasonable values for the pull-up resistor should range from 10k Ω to 100k Ω . Since the FAULT flag is an open drain terminal, it may be pulled up to any voltage that is not greater than the level present on the IN pin. This is done to allow the AAT4625 to signal ancillary circuitry that is powered by voltage levels less than the level on the IN pin.

If a fault flag delay greater than 10ms is required, addition delay may be added by use of an RC filter. An RC filter can be added to the fault flag output, as shown in Figure 1.

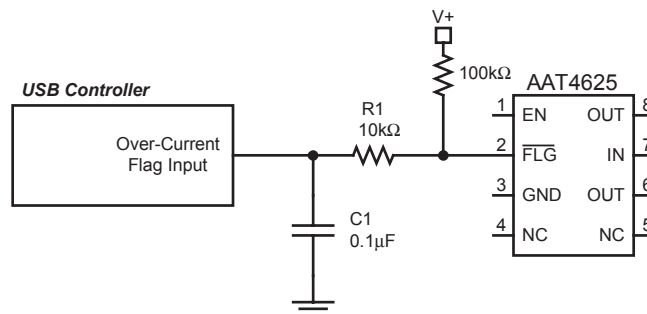

Figure 1: Fault Flag Delay RC Filter.

Reverse Voltage

The AAT4625 is designed to control current flowing from IN to OUT. If a voltage is applied to OUT which is greater than that on IN, a large reverse current may flow, potentially damaging the device.

Under-Voltage Lockout

The AAT4625 has been designed with an under-voltage lockout control circuit. The under-voltage lockout prevents the output MOSFET device from turning on until V_{IN} exceeds the typical UVLO threshold of 2.3V. During operation, the device will automatically shut down if V_{IN} falls below the UVLO threshold and the fault flag will be toggled.

Hot-Plug Applications

Application circuit cards with a high inrush current potential can be limited by use of the AAT4625. The AAT4625 has both slew rate limited turn-on characteristics and a current limit controlled output which make it ideally suited for power port hot-plug applications. A host power back plane or hot-plug receptacle may be sensitive to short duration, high power surges. The AAT4625 will turn on in a linear ramping fashion and regulate the inrush current within the specified current limit for the device. The error flag usually will not be affected during application turn-on, since the 10ms flag blanking time is intended for these types of events. If an application turn-on current surge exceeds 10ms, an RC delay filter may be added to the flag output to prevent the system from receiving an error during the start-up sequence (see Figure 2).

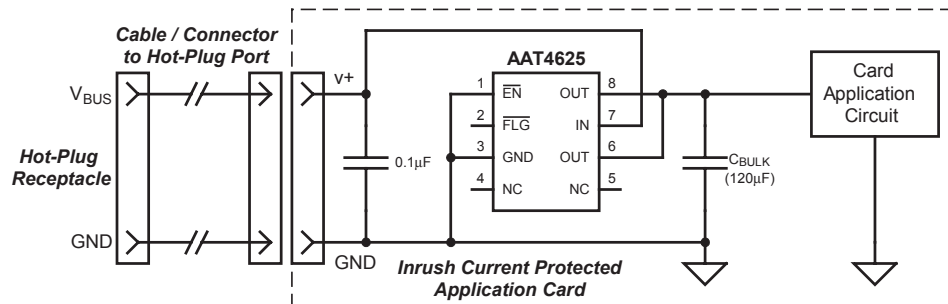

Figure 2: AAT4625 Inrush Current Protected Application.

PCB Layout Information

In order to obtain maximum performance from the AAT4625, very careful consideration must be given to the printed circuit board layout. In most port power switch and port protection applications, high

voltage and current transient events will occur. Proper PCB layout can help reduce the effects of transient events. PCB trace resistance will affect overall circuit transient response; in addition, small voltage drops will be incurred.

Refer to the following guidelines for power port PCB layout:

1. PCB traces should be kept as short and direct as possible to minimize the effects of the PCB on circuit performance.
2. Make component solder pads large to minimize contact resistance.
3. The AAT4625 output bulk capacitor and ferrite beads should be placed as close to the device as possible. PCB traces to the output connector should be kept as short as possible to minimize trace resistance and the associated voltage drop (I^2R loss).
4. If ferrite beads are used in the circuit, select ferrite beads with a minimum series resistance.
5. The use of PCB trace vias should be avoided on all traces that conduct high currents. If vias are necessary, make the vias as large as possible and use multiple vias connected in parallel to minimize their effect.

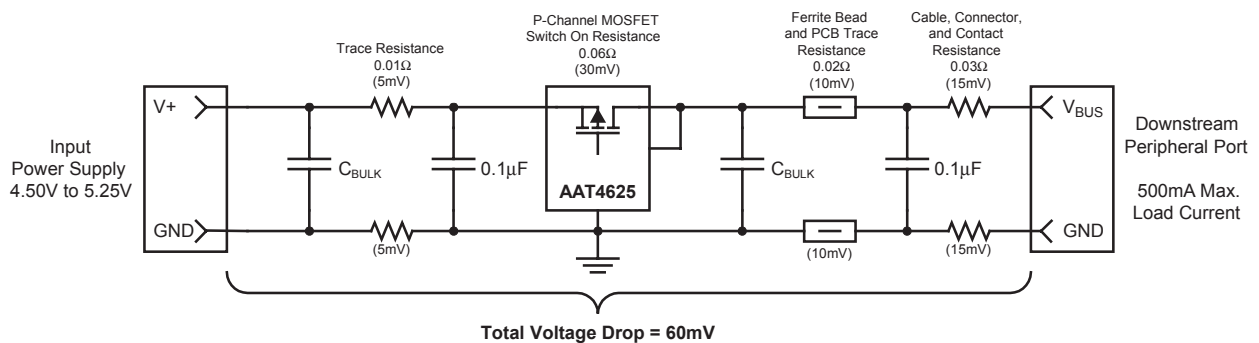

Figure 3: Summary of Typical Circuit Voltage Drops Caused by AAT4625 Circuit Components and PCB Trace Resistance.

Evaluation Board Layout

The AAT4625 evaluation layout (shown in Figures 4, 5, and 6) follows the recommend printed circuit board layout procedures and can be used as an

example for good application layouts. Note that ferrite beads are not used on this simple device evaluation board. The board layout shown is not to scale.

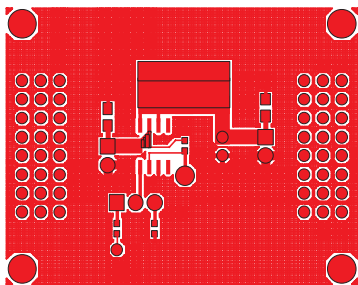

Figure 4: Evaluation Board Component Side Layout.

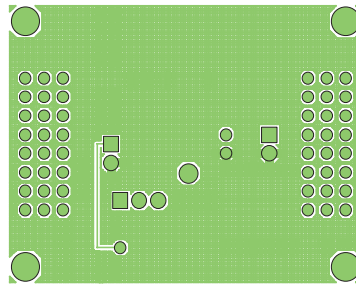

Figure 5: Evaluation Board Solder Side Layout.

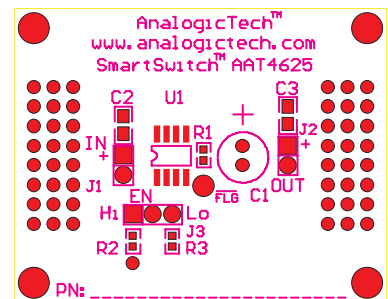

Figure 6: Evaluation Board Top Side Silk Screen Layout/ Assembly Drawing.

Application Circuits

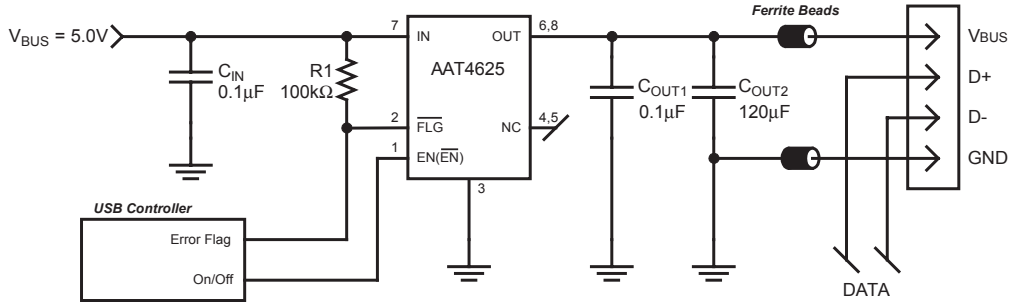

Figure 7: Typical USB Host Port Application.

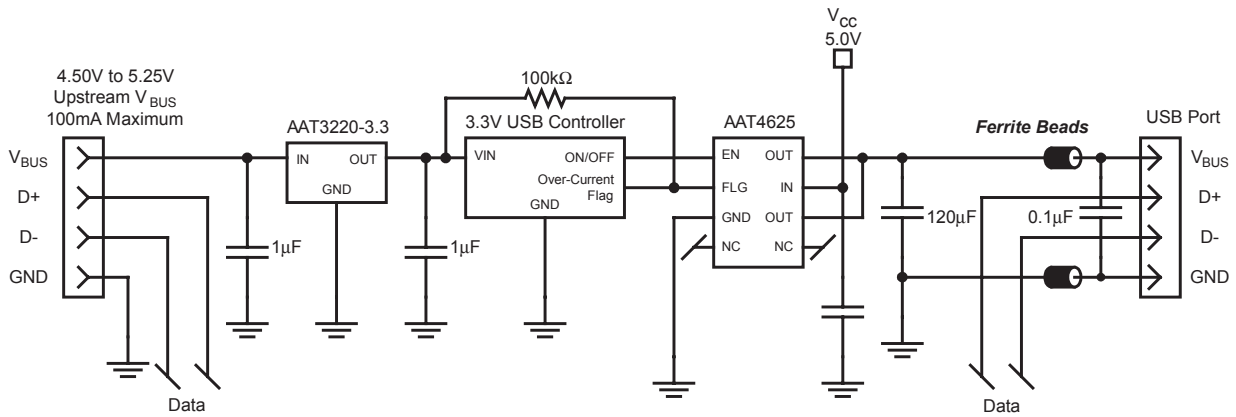

Figure 8: Self-Powered Single Port USB Hub.

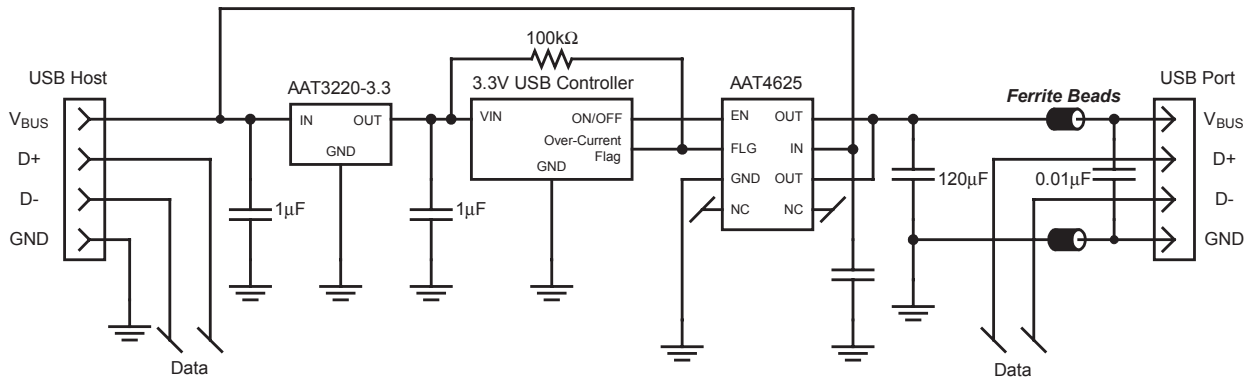

Figure 9: USB Bus Powered Single Port USB Hub.

Ordering Information

Package	Enable	Marking ¹	Part Number (Tape and Reel) ²
SOP-8	EN (Active-high)	4625-1	AAT4625IAS-1-T1
SOP-8	EN (Active-low)	4625	AAT4625IAS-T1
TSSOP-8	EN (Active-high)	4625-1	AAT4625IHS-1-T1
TSSOP-8	EN (Active-low)	4625	AAT4625IHS-T1
MSOP-8	EN (Active-high)	DDXYY	AAT4625IKS-1-T1
MSOP-8	EN (Active-low)	DCXYY	AAT4625IKS-T1



All AnalogicTech products are offered in Pb-free packaging. The term “Pb-free” means semiconductor products that are in compliance with current RoHS standards, including the requirement that lead not exceed 0.1% by weight in homogeneous materials. For more information, please visit our website at <http://www.analogictech.com/pbfree>.

Package Information

SOP-8

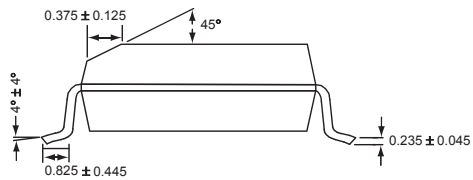
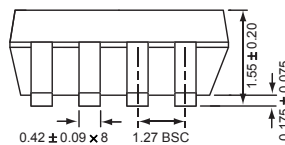
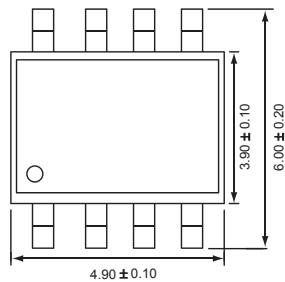

All dimensions in millimeters.

1. XYY = assembly and date code.
 2. Sample stock is generally held on part numbers listed in **BOLD**.

TSSOP-8

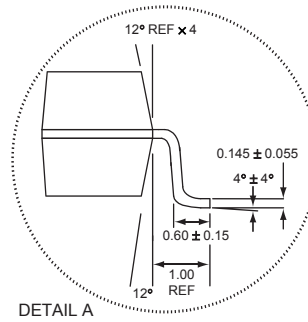
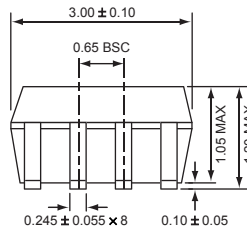
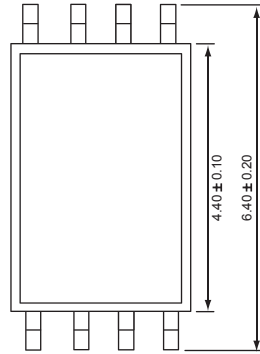

All dimensions in millimeters.

MSOP-8

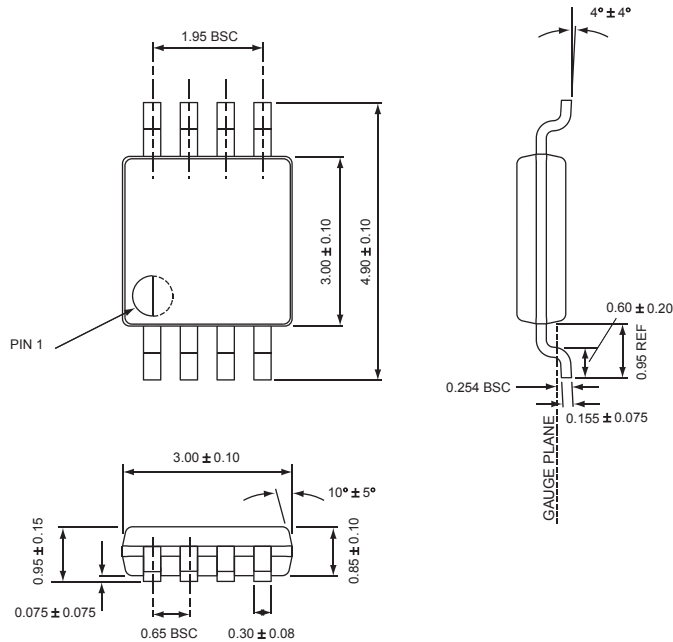

All dimensions in millimeters.

© Advanced Analogic Technologies, Inc.

AnalogicTech cannot assume responsibility for use of any circuitry other than circuitry entirely embodied in an AnalogicTech product. No circuit patent licenses, copyrights, mask work rights, or other intellectual property rights are implied. AnalogicTech reserves the right to make changes to their products or specifications or to discontinue any product or service without notice. Customers are advised to obtain the latest version of relevant information to verify, before placing orders, that information being relied on is current and complete. All products are sold subject to the terms and conditions of sale supplied at the time of order acknowledgement, including those pertaining to warranty, patent infringement, and limitation of liability. AnalogicTech warrants performance of its semiconductor products to the specifications applicable at the time of sale in accordance with AnalogicTech's standard warranty. Testing and other quality control techniques are utilized to the extent AnalogicTech deems necessary to support this warranty. Specific testing of all parameters of each device is not necessarily performed.

AnalogicTech and the AnalogicTech logo are trademarks of Advanced Analogic Technologies Incorporated. All other brand and product names appearing in this document are registered trademarks or trademarks of their respective holders.

Advanced Analogic Technologies, Inc.
 830 E. Arques Avenue, Sunnyvale, CA 94085
 Phone (408) 737-4600
 Fax (408) 737-4611