

10BASE-T NETWORK COMPONENTS

- Designed for use with AMD's eIMR (79C984A), eIMR+ (79C985) and IMR2 (79C983)/QuLET (79C988) chipsets
- Filterless quad, 4-port designs with common footprints and pinouts offering choice configurations for customized EMI suppression
- Best space and cost efficiency
- Low profile, surface mount packaging, rated to 225°C peak IR reflow temperature
- 2000 Vrms isolation

ELECTRICALS AT 25°C

Part No.	Insertion Loss (dB) Max 1-10MHz	OCL (μH) Min	Return Loss (dB) Min 5MHz-10MHz	Crosstalk (dB) Min 1MHz-10MHz	CM-CM Rej (dB) Min		Schematic
					10-30MHz	100MHz	
S553-5999-25	-1.0	100	-18	-40	-40	-30	A
S553-5999-26	-1.0	100	-18	-40	--	--	B
S553-5999-32	-1.0	100	-18	-40	-40	-30	C

SCHEMATICS

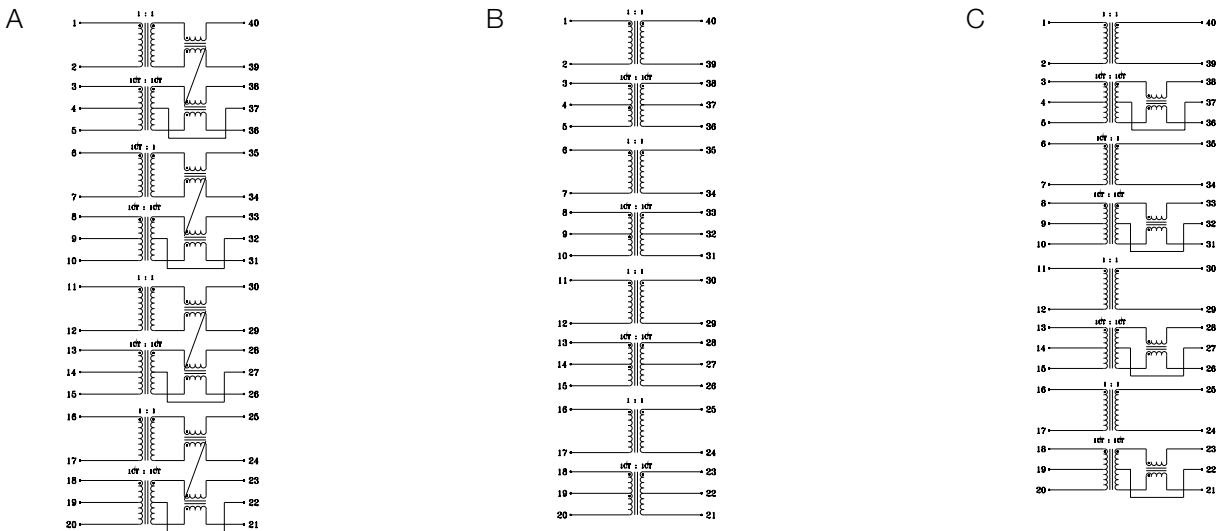

MECHANICAL

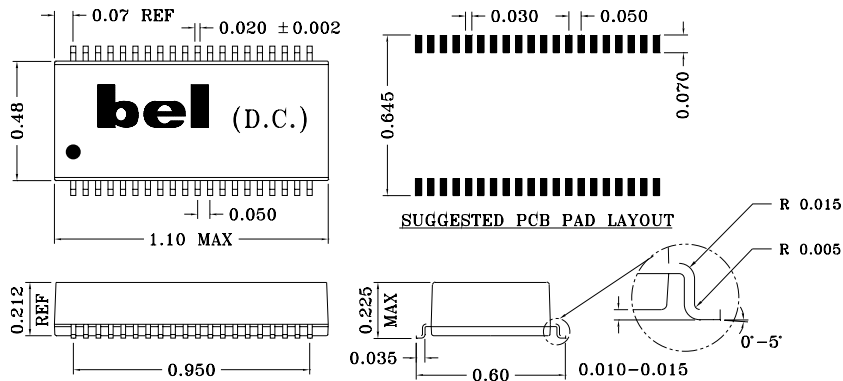

Specifications subject to change without notice.

10BASE-T NETWORK COMPONENTS

960064A

APPLICATION CIRCUIT

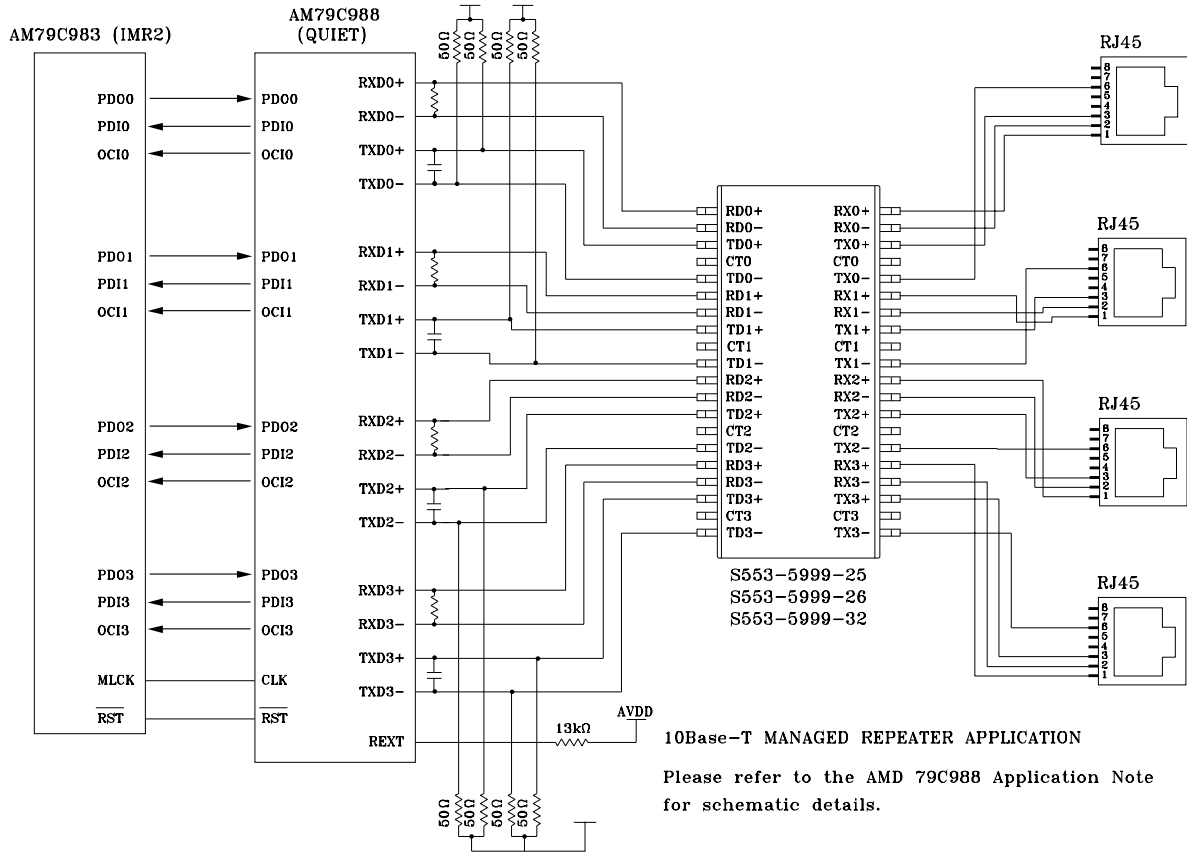

APPLICATION NOTES

- Bel has developed a variety of quad, 4-port part types for use with AMD's product line of quad, 4-port PHY transceivers that incorporate digital filtering techniques within the silicon itself. Bel's "filterless magnetics" are optimized for this specific application and create a very cost efficient design solution. Each Bel part type contains transmit and receive transformers to provide for wave shaping, high voltage isolation and EMI noise suppression.
- Bel has designed these parts as a family of parts with common footprint and pinouts to enable the designer to customize the use of common mode choke for optimum system performance.
- In multi-port system applications, good PCB layout and proper grounding techniques are very critical to achieve FCC class A and B equipment approvals. Bel recommendations are available and can be provided by contacting our engineering department or your local sales representative.
- Bel's low profile, surface mount packaging is ideal for high speed pick and place machinery. Parts can be shipped on tape and reel for high speed placement. Construction processes have been implemented for thermal compatibility with high temperature IR reflow assembly processing. Post dipping of leads assist with PC board solderability. Each part is optically inspected to meet rigid coplanarity requirements.

Corporate Office
Bel Fuse Inc.
 198 Van Vorst Street, Jersey City, NJ 07302-4496
 Tel: 201-432-0463
 Fax: 201-432-9542
 E-Mail: BelFuse@belfuse.com
 Internet: http://www.belfuse.com

Far East Office
Bel Fuse Ltd.
 8F/8 Luk Hop Street
 San Po Kong
 Kowloon, Hong Kong
 Tel: 852-2328-5515
 Fax: 852-2352-3706

European Office
Bel Fuse Europe Ltd.
 Preston Technology Management Centre
 Marsh Lane, Preston PR1 8UD
 Lancashire, U.K.
 Tel: 44-1772-556601
 Fax: 44-1772-888366