

Low Power High Speed Digital Coupler

Functional Diagram

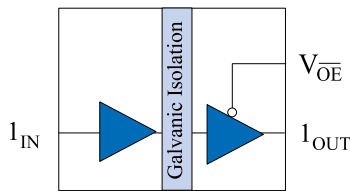

Features

- +5V/+3.3V CMOS/TTL Compatible
- High Speed: 110 MBd
- 2500VRMS Isolation (1 Min.)
- 2 ns Typical Pulse Width Distortion
- 4 ns Typical Propagation Delay Skew
- 10 ns Typical Propagation Delay
- 30 kV/us Typical Common Mode Rejection
- Tri State Output
- 8-pin PDIP and 8-pin SOIC Packages
- UL1577 Approval Pending
- IEC 61010-1 Approval Pending

Isolation Applications

- Digital Fieldbus
- USB, RS485 and RS422
- Multiplexed Data Transmission
- Data Interfaces
- Board-To-Board Communication
- Digital Noise Reduction
- Operator Interface
- Ground Loop Elimination
- Peripheral Interfaces
- Serial Communication
- Logic Level Shifting

Description

The IL7710 is a lower power version of NVE's popular IL710 device. It features half the quiescent current consumption of the IL710 but has equivalent dynamic specifications. Fabricated with NVE's patented IsoLoop technology, the IL7710 has only 10 ns typical propagation delay and 2ns pulse width distortion. The IL7710's specifications are valid over the industrial temperature range of -40°C to +85°C.

IL7710 ^{IsoLoop®}

Absolute Maximum Ratings

Parameters	Symbol	Min.	Max.	Units
Storage Temperature	T _S	-55	175	°C
Ambient Operating Temperature ⁽¹⁾	T _A	-55	125	°C
Supply Voltage	V _{DD1} , V _{DD2}	-0.5	7	Volts
Input Voltage	V _I	-0.5	V _{DD1} +0.5	Volts
Input Voltage	V _{OE}	-0.5	V _{DD2} +0.5	Volts
Output Voltage	V _O	-0.5	V _{DD2} +0.5	Volts
Output Current Drive	I _O		10	mA
Lead Solder Temperature (10s)			260	°C
ESD	2kV Human Body Model			

Recommended Operating Conditions

Parameters	Symbol	Min.	Max.	Units
Ambient Operating Temperature	T _A	-40	85	°C
Supply Voltage (3.3/5.0 V operation)	V _{DD1} , V _{DD2}	3.0	5.5	Volts
Supply Voltage (5.0 V operation)	V _{DD1} , V _{DD2}	4.5	5.5	Volts
Logic High Input Voltage	V _{IH}	2.4	V _{DD1}	Volts
Logic Low Input Voltage	V _{IL}	0	0.8	Volts
Minimum Signal Rise and Fall Times	t _{IR} , t _{IF}		1	µsec

Insulation Specifications

Parameter	Condition	Min.	Typ.	Max.	Units
Barrier Impedance			>10 ¹⁴ 3		Ω pF
Creepage Distance (External)		7.036 (PDIP) 4.026 (SOIC)			mm
Leakage Current	240 V _{RMS} 60Hz		0.2		µA

Package Characteristics

Parameter	Symbol	Min.	Typ.	Max.	Units	Test Conditions
Capacitance (Input-Output) ⁽⁵⁾	C _{I-O}		1.1		pF	f= 1MHz
Thermal Resistance (PDIP)	θ _{JCT}		54		°C/W	Thermocouple located at center underside of package
(SOIC)	θ _{JCT}		144		°C/W	
Package Power Dissipation	P _{PD}			15	mW	f= 1MHz, V _{DD} =5V

IEC61010-1

TUV Certificate Numbers: Pending (PDIP)
Pending (SOIC)

Classification as Table 1.

Model	Pollution Degree	Material Group	Max Working Voltage	Package Type	
				8-PDIP	8-SOIC
IL7710-2	II	III	300 VRMS	✓	
IL7710-3	II	III	150 VRMS		✓

UL 1577

Component Recognition program. File # Pending
Rated 2500Vrms for 1min.

Electrical Specifications

Electrical Specifications are T_{min} to T_{max} unless otherwise stated.

Parameter	Symbol	3.3 Volt Specifications			5.0 Volt Specifications			Units	Test Conditions
		Min.	Typ.	Max.	Min.	Typ.	Max.		
DC Specifications									
Input Quiescent Supply Current	I_{DD1}		8	10		10	15	μA	
Output Quiescent Supply Current	I_{DD2}		1.7	2		2.5	3	mA	
Logic Input Current	I_I	-10		10	-10		10	μA	
Logic High Output Voltage	V_{OH}	$V_{DD2}-0.1$ $0.8*V_{DD2}$	V_{DD2} $V_{DD2}-0.5$		$V_{DD2}-0.1$ $0.8*V_{DD2}$	V_{DD2} $V_{DD2}-0.5$		V	$I_O = -20 \mu A, V_I = V_{IH}$ $I_O = -4 mA, V_I = V_{IH}$
Logic Low Output Voltage	V_{OL}		0 0.5	0.1 0.8		0 0.5	0.1 0.8	V	$I_O = 20 \mu A, V_I = V_{IL}$ $I_O = 4 mA, V_I = V_{IL}$
Switching Specifications									
Maximum Data Rate		100	110		100	110		MBd	$C_L = 15 pF$
Pulse Width	PW	10			10			ns	
Propagation Delay Input to Output (High to Low)	t_{PHL}		12	18		10	15	ns	$C_L = 15 pF$
Propagation Delay Input to Output (Low to High)	t_{PLH}		12	18		10	15	ns	$C_L = 15 pF$
Propagation Delay Enable to Output (High to High Impedance)	t_{PHZ}		3	5		3	5	ns	$C_L = 15 pF$
Propagation Delay Enable to Output (Low to High Impedance)	t_{PLZ}		3	5		3	5	ns	$C_L = 15 pF$
Propagation Delay Enable to Output (High Impedance to High)	t_{PZH}		3	5		3	5	ns	$C_L = 15 pF$
Propagation Delay Enable to Output (High Impedance to Low)	t_{PZL}		3	5		3	5	ns	$C_L = 15 pF$
Pulse Width Distortion ⁽²⁾			2	3		2	3		
Propagation Delay Skew ⁽³⁾	t_{PSK}		4	6		4	6	ns	$C_L = 15 pF$
Output Rise Time (10-90%)	t_R		2	4		1	3	ns	$C_L = 15 pF$
Output Fall Time (10-90%)	t_F		2	4		1	3	ns	$C_L = 15 pF$
Common Mode Transient Immunity (Output Logic High or Logic Low) ⁽⁴⁾	$ CMH $ $ CML $	20	30		20	30		kV/ μs	$V_{cm} = 300V$

Notes:

1. Absolute Maximum ambient operating temperature means the device will not be damaged if operated under these conditions. It does not guarantee performance.
2. PWD is defined as $|t_{PHL} - t_{PLH}|$. %PWD is equal to the PWD divided by the pulse width.
3. t_{PSK} is equal to the magnitude of the worst case difference in t_{PHL} and/or t_{PLH} that will be seen between units at 25°C.
4. CM_H is the maximum common mode voltage slew rate that can be sustained while maintaining $V_O > 0.8 V_{DD2}$. CM_L is the maximum common mode input voltage that can be sustained while maintaining $V_O < 0.8 V$. The common mode voltage slew rates apply to both rising and falling common mode voltage edges.
5. Device is considered a two terminal device:
pins 1-4 shorted and pins 5-8 shorted.

Application Notes:

Dynamic Power Consumption

IsoLoop® devices achieve their low power consumption from the manner by which they transmit data across the isolation barrier. By detecting the edge transitions of the input logic signal and converting these to narrow current pulses, a magnetic field is created around the GMR Wheatstone bridge. Depending on the direction of the magnetic field, the bridge causes the output comparator to switch following the input logic signal. Since the current pulses are narrow, about 2.5ns wide, the power consumption is independent of mark-to-space ratio and solely dependent on frequency. This has obvious advantages over optocouplers whose power consumption is heavily dependent on its on-state and frequency.

The approximate power supply current per channel for IsoLoop® is:

$$I(\text{input}) = 40 \left(\frac{f}{f_{\text{max}}} \right) \left(\frac{1}{4} \right) \text{ mA}$$

where f = operating frequency
 f_{max} = 50 MHz

Power Supply Decoupling

Both power supplies to these devices should be decoupled with low ESR 47 nF ceramic capacitors. For data rates in excess of 10MBd, use of ground planes for both GND1 and GND2 is highly recommended. Capacitors should be located as close as possible to the device.

Signal Status on Start-up and Shut Down

To minimize power dissipation, the input signals are differentiated and then latched on the output side of the isolation barrier to reconstruct the signal. This could result in an ambiguous output state depending on power up, shutdown and power loss sequencing. Therefore, the designer should consider the inclusion of an initialization signal in his start-up circuit. Initialization consists of toggling the input either high then low or low then high, depending on the desired state.

Electrostatic Discharge Sensitivity

This product has been tested for electrostatic sensitivity to the limits stated in the specifications. However, NVE recommends that all integrated circuits be handled with appropriate care to avoid damage. Damage caused by inappropriate handling or storage could range from performance degradation to complete failure.

Data Transmission Rates

The reliability of a transmission system is directly related to the accuracy and quality of the transmitted digital information. For a digital system, those parameters which determine the limits of the data transmission are *pulse width distortion* and *propagation delay skew*.

Propagation delay is the time taken for the signal to travel through the device. This is usually different when sending a low-to-high than when sending a high-to-low signal. This difference, or error, is called pulse width distortion (PWD) and is usually in ns. It may also be expressed as a percentage:

$$\text{PWD}\% = \frac{\text{Maximum Pulse Width Distortion (ns)}}{\text{Signal Pulse Width (ns)}} \times 100\%$$

For example: For data rates of 12.5 Mb

$$\text{PWD}\% = \frac{3 \text{ ns}}{80 \text{ ns}} \times 100\% = 3.75\%$$

This figure is almost **three times** better than for any available optocoupler with the same temperature range, and **two times** better than any optocoupler regardless of published temperature range. The IsoLoop® range of isolators surpasses the 10% maximum PWD recommended by PROFIBUS, and will run at almost 35 Mb before reaching the 10% limit.

Propagation delay skew is the difference in time taken for two or more channels to propagate their signals. This becomes significant when clocking is involved since it is undesirable for the clock pulse to arrive before the data has settled. A short propagation delay skew is therefore critical, especially in high data rate parallel systems, to establish and maintain accuracy and repeatability. The IsoLoop® range of isolators all have a maximum propagation delay skew of 6 ns, which is **five times** better than any optocoupler.

Applications

Isolated RS-485

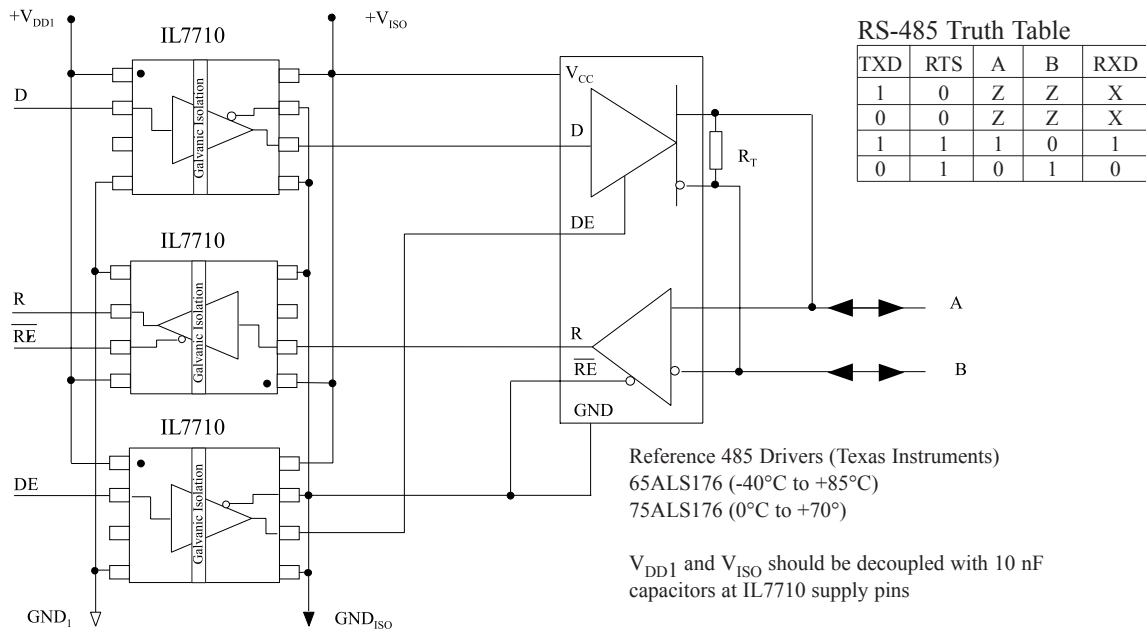

USB

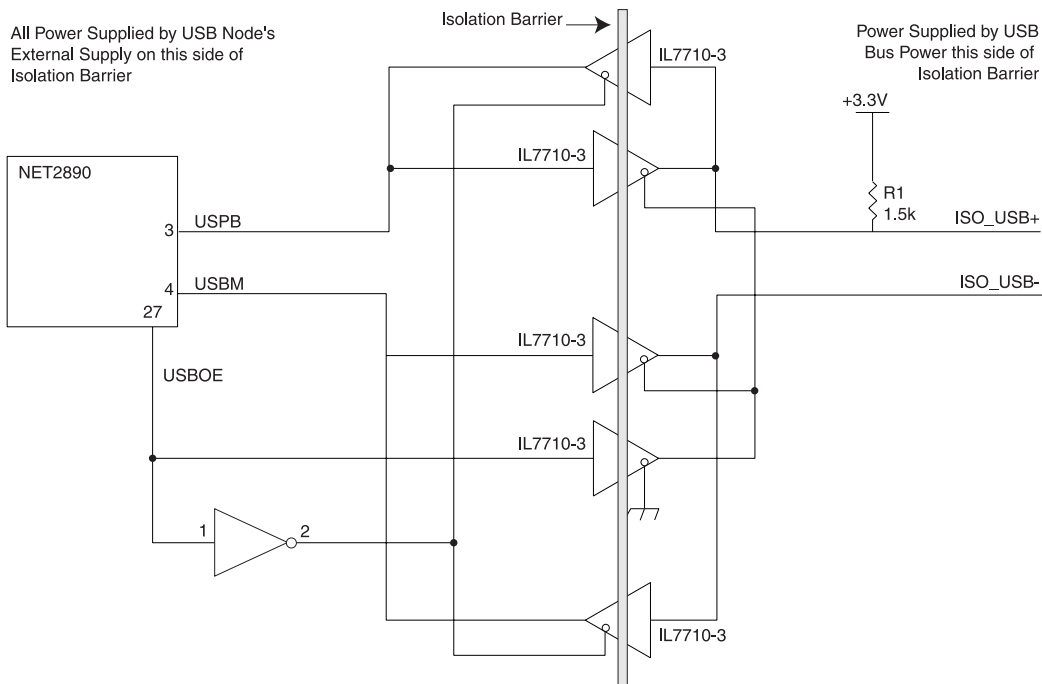

IL7710 IsoLoop®

Pin Configuration

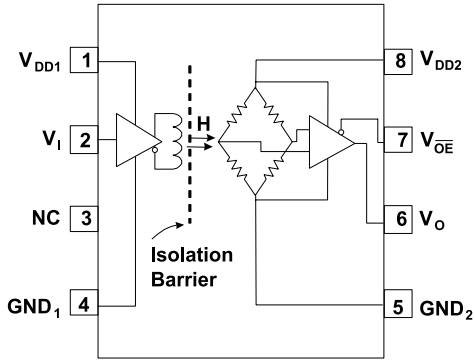

Truth Table

V_I	V_{OE}	V_O
L	L	L
H	L	H
L	H	Z
H	H	Z

Timing Diagram

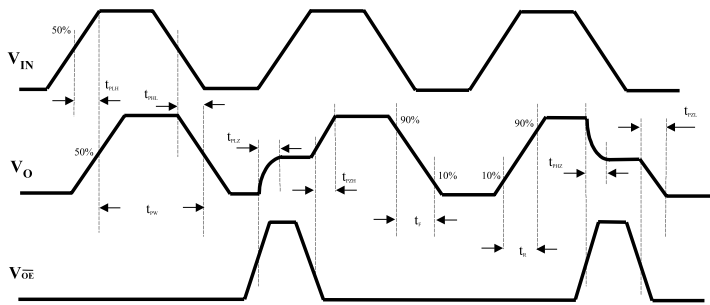

Legend

t_{PLH}	Propagation Delay, Low to High
t_{PHL}	Propagation Delay, High to Low
t_{PW}	Minimum Pulse Width
t_{PLZ}	Propagation Delay, Low to High Impedance
t_{PZH}	Propagation Delay, High Impedance to High
t_{PHZ}	Propagation Delay, High to High Impedance
t_{PZL}	Propagation Delay, High Impedance to Low
t_R	Rise Time
t_F	Fall Time

IR Soldering Profile

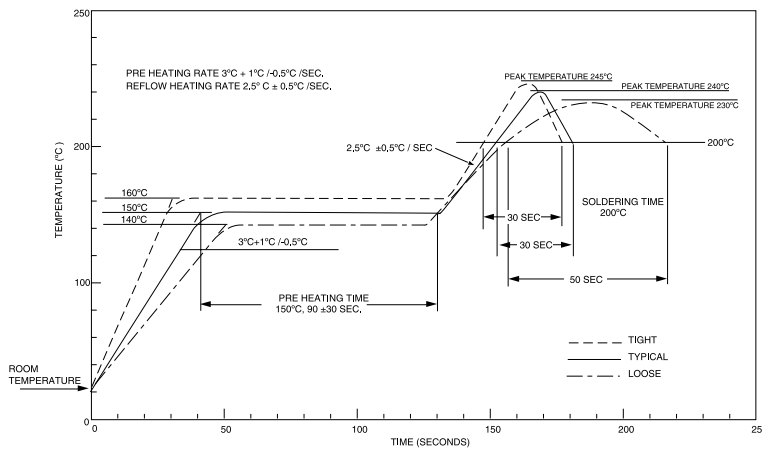

Recommended profile shown. Maximum temperature allowed on any profile is 260°C .

IL7710-2 (8-Pin PDIP Package)

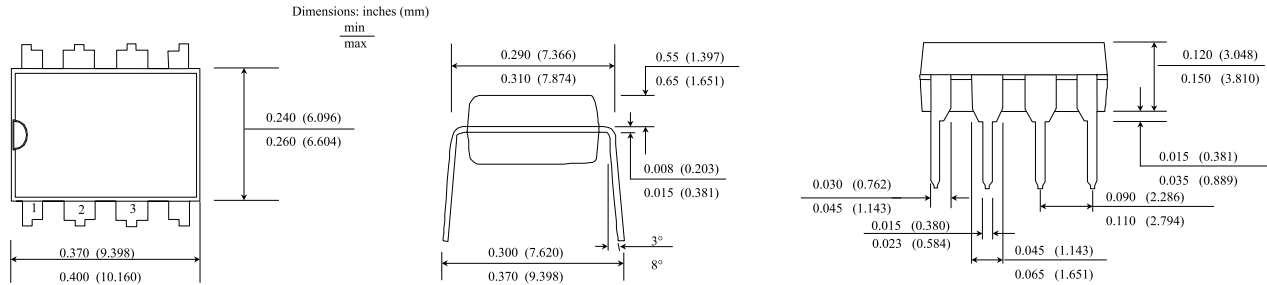

IL7710-3 (Small Outline SOIC-8 package)

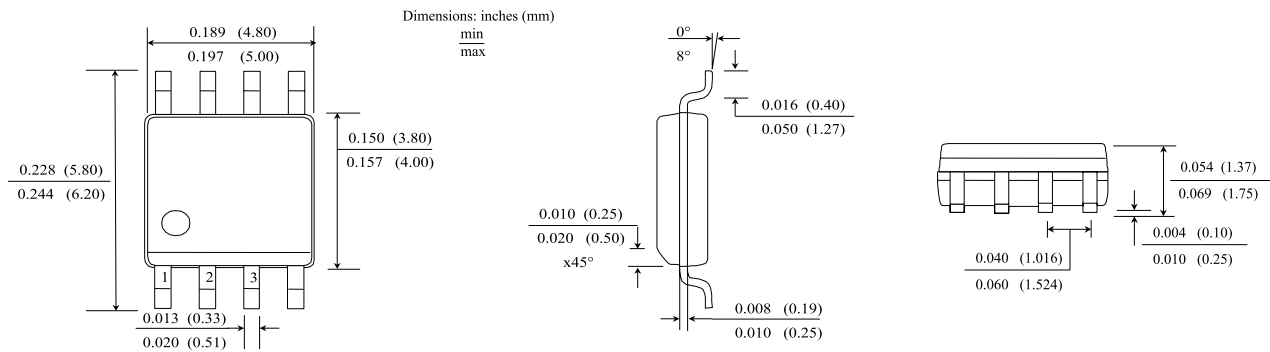

Ordering Information: use the following format to order these devices

IL 7710 -2 TR7

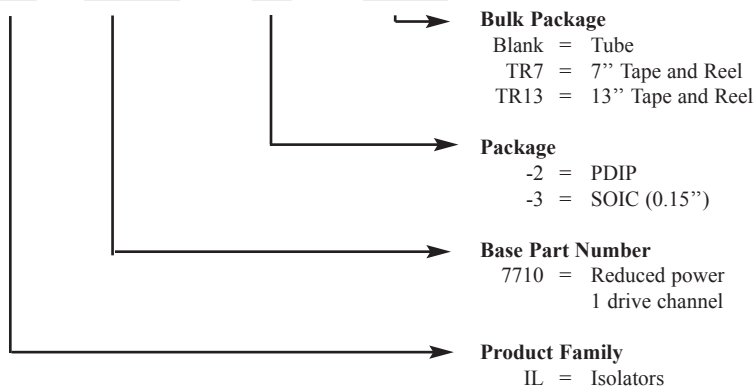

Valid Part Numbers

IL 7710-2
 IL 7710-3
 IL 7710-3TR13
 IL 7710-3TR7



About NVE

NVE Corporation is a world leader in the practical commercialization of "spintronics," which many experts believe represents the next generation of microelectronics — the successor to the transistor. Unlike conventional electronics, which rely on electron charge, spintronics uses electron spin to store and transmit information. Spintronics devices are smaller, faster, and more accurate, compared to charge-based microelectronics.

It is the spin of electrons that causes magnetism. NVE's products use proprietary spintronic materials called Giant Magnetoresistors (GMR). These materials are made of exotic alloys a few atoms thick, and provide very large signals (the "Giant" in "Giant Magnetoresistor"). NVE has the unique capability to combine leading edge GMR materials with integrated circuits to make high performance electronic components.

We are pioneers in creating practical products using this revolutionary technology and introduced the world's first GMR products in 1994. We also license spintronics/Magnetic Random Access Memory (MRAM) designs to world-class memory manufacturers.

Our products include:

- Digital Signal Isolators
- Isolated Bus Transceivers
- Magnetic Field Sensors
- Magnetic Field Gradient Sensors (Gradiometer)
- Digital Magnetic Field Sensors.

NVE Corporation
11409 Valley View Road
Eden Prairie, Mn 55344-3617 USA
Telephone: (952) 829-9217
Fax: (952) 829-9189
Internet: www.nve.com
e-mail: isoinfo@nve.com

The information provided by NVE Corporation is believed to be accurate. However, no responsibility is assumed by NVE Corporation for its use, nor for any infringement of patents, nor rights or licenses granted to third parties, which may result from its use. No license is granted by implication, or otherwise, under any patent or patent rights of NVE Corporation. NVE Corporation does not authorize, nor warrant, any NVE Corporation product for use in life support devices or systems or other critical applications. The use of NVE Corporation's products in such applications is understood to be entirely at the customer's own risk.

Specifications shown are subject to change without notice.



ISB-DS-001-IL7710-A
November 2003