



Features

- Radial Leaded Devices
- Cured, flame retardant epoxy polymer insulating material meets UL 94V-0 requirements
- Bulk packaging, tape and reel and Ammo-Pak available on most models
- Agency recognition:   

Applications

- Almost anywhere there is a low voltage power supply, up to 60V and a load to be protected, including:
- Security and fire alarm systems
 - Loud speakers
 - Power transformers

MF-RX Series - PTC Resettable Fuses

Electrical Characteristics

Model	V max. Volts	I max. Amps	I_{hold}	I_{trip}	Initial Resistance		1 Hour (R_1) Post-Trip Resistance	Max. Time To Trip		Tripped Power Dissipation
			Amperes at 23°C		Ohms at 23°C			Amperes at 23°C	Seconds at 23°C	
			Hold	Trip	Min.	Max.	Max.			
MF-RX110	60	40	1.10	2.20	0.15	0.25	0.38	5.5	8.2	1.50
MF-RX135	60	40	1.35	2.70	0.12	0.19	0.30	6.75	9.6	1.70
MF-RX160	60	40	1.60	3.20	0.09	0.14	0.22	8.0	11.4	1.90
MF-RX185	60	40	1.85	3.70	0.08	0.12	0.19	9.25	12.6	2.10
MF-RX250	60	40	2.50	5.00	0.05	0.08	0.13	12.5	15.6	2.50
MF-RX300	60	40	3.00	6.00	0.04	0.06	0.10	15.0	19.8	2.80
MF-RX375	60	40	3.75	7.50	0.03	0.05	0.08	18.75	24.0	3.20

Environmental Characteristics

Operating/Storage Temperature-40°C to +85°C
Maximum Device Surface Temperature	
in Tripped State125°C
Passive Aging+85°C, 1000 hours±5% typical resistance change
Humidity Aging+85°C, 85% R.H. 1000 hours.....±5% typical resistance change
Thermal Shock+125°C to -55°C, 10 times±10% typical resistance change
Solvent ResistanceMIL-STD-202, Method 215No change
VibrationMIL-STD-883C, Method 2007.1,No change Condition A

Test Procedures And Requirements For Model MF-RX Series

Test	Test Conditions	Accept/Reject Criteria
Visual/Mech.Verify dimensions and materials.....Per MF physical description
ResistanceIn still air @ 23°C $R_{min} \leq R \leq R_{max}$
Time to Trip5 times I_{hold} , V_{max} , 23°C $T \leq \text{max. time to trip (seconds)}$
Hold Current30 min. at I_{hold}No trip
Trip Cycle Life V_{max} , I_{max} , 100 cyclesNo arcing or burning
Trip Endurance V_{max} , 48 hoursNo arcing or burning
UL File NumberE 174545S	
CSA File NumberCA 110338	
TÜV File NumberR2057213	

Thermal Derating Chart - I_{hold} / I_{trip} (Amps)

Model	Ambient Operating Temperature								
	-40°C	-20°C	0°C	23°C	40°C	50°C	60°C	70°C	85°C
MF-RX110	1.71 / 3.42	1.50 / 3.00	1.31 / 2.62	1.10 / 2.20	0.89 / 1.78	0.79 / 1.58	0.69 / 1.38	0.59 / 1.18	0.44 / 0.88
MF-RX135	2.09 / 4.18	1.84 / 3.68	1.61 / 3.22	1.35 / 2.70	1.09 / 2.18	0.97 / 1.94	0.85 / 1.70	0.73 / 1.46	0.54 / 1.08
MF-RX160	2.48 / 4.96	2.18 / 4.36	1.90 / 3.80	1.60 / 3.20	1.30 / 2.60	1.15 / 2.30	1.01 / 2.02	0.86 / 1.72	0.64 / 1.28
MF-RX185	2.87 / 5.74	2.52 / 5.04	2.20 / 4.40	1.85 / 3.70	1.50 / 3.00	1.33 / 2.66	1.17 / 2.34	1.00 / 2.00	0.74 / 1.48
MF-RX250	3.88 / 7.76	3.40 / 6.80	2.98 / 5.96	2.50 / 5.00	2.03 / 4.06	1.80 / 3.60	1.58 / 3.16	1.35 / 2.70	1.00 / 2.00
MF-RX300	4.65 / 9.30	4.08 / 8.16	3.57 / 7.14	3.00 / 6.00	2.43 / 4.86	2.16 / 4.32	1.89 / 3.78	1.62 / 3.24	1.20 / 2.40
MF-RX375	5.81 / 11.6	5.10 / 10.2	4.46 / 8.92	3.75 / 7.50	3.04 / 6.08	2.70 / 5.40	2.36 / 4.72	2.03 / 4.06	1.50 / 3.00

Additional Features

- Resettable circuit protection
- Patents pending

MF-RX Series - PTC Resettable Fuses

BOURNS®

Product Dimensions

Model	A	B	C		D	E	Physical Characteristics		
	Max.	Max.	Nom.	Tol. ±	Min.	Max.	Style	Lead Dia.	Material
MF-RX110	13.0 (0.512)	18.0 (0.709)	5.1 (0.201)	0.7 (0.028)	7.6 (0.299)	3.1 (0.122)	1	0.81 (0.032)	Sn/Cu
MF-RX135	14.5 (0.571)	19.6 (0.772)	5.1 (0.201)	0.7 (0.028)	7.6 (0.299)	3.1 (0.122)	1	0.81 (0.032)	Sn/Cu
MF-RX160	16.3 (0.642)	21.3 (0.839)	5.1 (0.201)	0.7 (0.028)	7.6 (0.299)	3.1 (0.122)	1	0.81 (0.032)	Sn/Cu
MF-RX185	17.8 (0.701)	22.9 (0.902)	5.1 (0.201)	0.7 (0.028)	7.6 (0.299)	3.1 (0.122)	1	0.81 (0.032)	Sn/Cu
MF-RX250	21.3 (0.839)	26.4 (1.039)	10.2 (0.402)	0.7 (0.028)	7.6 (0.299)	3.1 (0.122)	1	0.81 (0.032)	Sn/Cu
MF-RX300	24.9 (0.980)	30.0 (1.181)	10.2 (0.402)	0.7 (0.028)	7.6 (0.299)	3.1 (0.122)	1	0.81 (0.032)	Sn/Cu
MF-RX375	28.4 (1.118)	33.5 (1.319)	10.2 (0.402)	0.7 (0.028)	7.6 (0.299)	3.1 (0.122)	1	0.81 (0.032)	Sn/Cu

Packaging options:

BULK: All models = 500 pcs. per bag.

TAPE & REEL: MF-RX110 – MF-RX160 = 1500 pcs. per reel; MF-RX185 – MF-RX375 = 1000 pcs. per reel

AMMO-PACK: MF-RX110 – MF-RX160 = 1000 pcs. per reel; MF-RX185 – MF-RX375 = 500 pcs. per reel

0.81 (20AWG)

DIMENSIONS = $\frac{\text{MM}}{\text{(INCHES)}}$

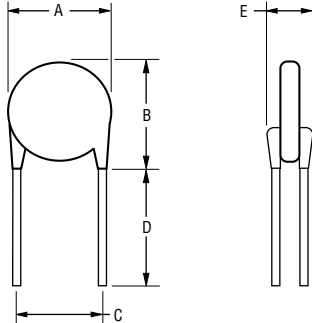

NOTE: Kinked lead option is available for board standoff. Contact factory for details.

Typical Part Marking

Represents total content. Layout may vary.

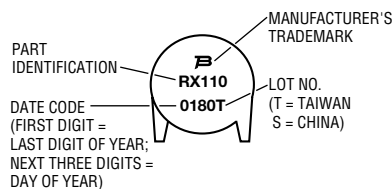

How to Order

MF - RX 110 -

Multifuse® Product Designator

Series **RX** = Radial Leded Component

Hold Current, I_{hold} **110-375** (1.10 Amps - 3.75 Amps)

Packaging Options

- = Bulk Packaging
- 2 = Tape and Reel*
- AP = Ammo-Pak*

*Packaged per EIA 486-B

Typical Time to Trip at 23°C

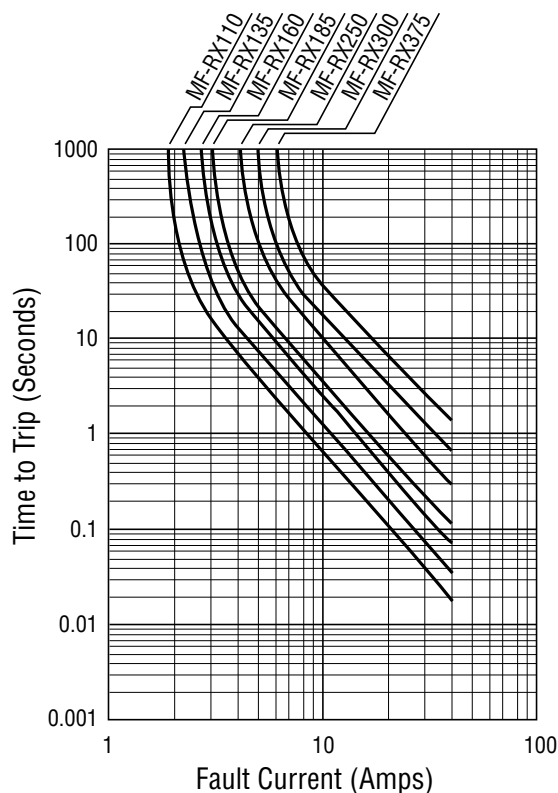

MF-RX SERIES, REV. G, 08/01

Specifications are subject to change without notice.

Tape and Reel Specifications

MF-R, MF-RX & MF-R/250 Series Tape and Reel Specifications

BOURNS®

Devices taped using EIA468-B/IEC286-2 standards. See table below and Figures 1 and 2 for details.

Dimension Description	IEC Mark	EIA Mark	Dimensions	
			Dimensions	Tolerance
Carrier tape width	<i>W</i>	<i>W</i>	$\frac{18}{(.709)}$	$\frac{-0.5/+1.0}{(-0.02/+0.039)}$
Hold down tape width		<i>W4</i>	$\frac{5}{(.197)}$	min.
Hold down tape	<i>W0</i>		No protrusion	
Top distance between tape edges	<i>W2</i>	<i>W6</i>	$\frac{3}{(.118)}$	max.
Sprocket hole position	<i>W1</i>	<i>W5</i>	$\frac{9}{(.354)}$	$\frac{-0.5/+0.75}{(-0.02/+0.03)}$
Sprocket hole diameter	<i>D0</i>	<i>D0</i>	$\frac{4}{(.157)}$	$\frac{\pm 0.2}{(\pm .0078)}$
Abscissa to plane (straight lead)	<i>H</i>	<i>H</i>	$\frac{18.5}{(.728)}$	$\frac{\pm 3.0}{(\pm .118)}$
Abscissa to plane (kinked lead)	<i>H0</i>	<i>H0</i>	$\frac{16}{(.63)}$	$\frac{\pm 0.5}{(\pm .02)}$
Abscissa to top	<i>H1</i>	<i>H1</i>	$\frac{32.2}{(1.268)}$	max.
Overall width w/lead protrusion		<i>C1</i>	$\frac{43.2}{(1.7)}$	max.
Overall width w/o lead protrusion		<i>C2</i>	$\frac{42.5}{(1.673)}$	max.
Lead protrusion	<i>I1</i>	<i>L1</i>	$\frac{1.0}{(.039)}$	max.
Protrusion of cutout	<i>L</i>	<i>L</i>	$\frac{11}{(.433)}$	max.
Protrusion beyond hold tape	<i>I2</i>	<i>I2</i>	Not specified	
Sprocket hole pitch	<i>P0</i>	<i>P0</i>	$\frac{12.7}{(0.5)}$	$\frac{\pm 0.3}{(\pm .012)}$
Pitch tolerance			20 seconds	± 1 second
Device pitch: MF-R010 – MF-R160			$\frac{12.7}{(0.5)}$	
Device pitch: MF-R185 – MF-R400			$\frac{25.4}{(1.0)}$	
Device pitch: MF-RX110 – MF-RX160			$\frac{12.7}{(0.5)}$	
Device pitch: MF-RX185 – MF-RX375			$\frac{12.7}{(0.5)}$	
Device pitch: MF-R012/250			$\frac{25.4}{(1.0)}$	
Tape thickness	<i>t</i>	<i>t</i>	$\frac{0.9}{(.035)}$	max.
Tape thickness with splice		<i>t1</i>	$\frac{2.0}{(.079)}$	max.
Splice sprocket hole alignment			0	$\frac{\pm 0.3}{(\pm .012)}$
Body lateral deviation	Δh	Δh	0	$\frac{\pm 1.0}{(\pm .039)}$
Body tape plane deviation	Δp	Δp	0	$\frac{\pm 1.3}{(\pm .051)}$
Lead seating plane deviation	$\Delta P1$	<i>P1</i>	0	$\frac{\pm 0.7}{(\pm .028)}$
Lead spacing	<i>F</i>	<i>F</i>	$\frac{5.08}{(0.2)}$	$\frac{\pm 0.8}{(\pm .035)}$
Reel width	<i>w</i>	<i>w</i>	$\frac{56}{(2.205)}$	max.
Reel diameter	<i>d</i>	<i>a</i>	$\frac{370}{(14.57)}$	max.
Space between flanges less device			$\frac{4.75}{(.187)}$	$\frac{\pm 3.25}{(\pm .128)}$

DIMENSIONS = $\frac{\text{MM}}{\text{(INCHES)}}$

Dimension Description	IEC Mark	EIA Mark	Dimensions	
			Dimensions	Tolerance
Space between flanges less device			$\frac{4.75}{(.187)}$	$\frac{\pm 3.25}{(\pm .128)}$
Arbor hole diameter	<i>f</i>	<i>c</i>	$\frac{26}{(1.024)}$	$\frac{\pm 12.0}{(\pm .472)}$
Core diameter	<i>h</i>	<i>n</i>	$\frac{80}{(3.15)}$	max.
Box			$\frac{56}{(2.2)}$ $\frac{372}{(14.6)}$ $\frac{372}{(14.6)}$	max.
Consecutive missing places			3 maximum	
Empty places per reel			Not specified	

DIMENSIONS = $\frac{\text{MM}}{\text{(INCHES)}}$

Taped Component Dimensions

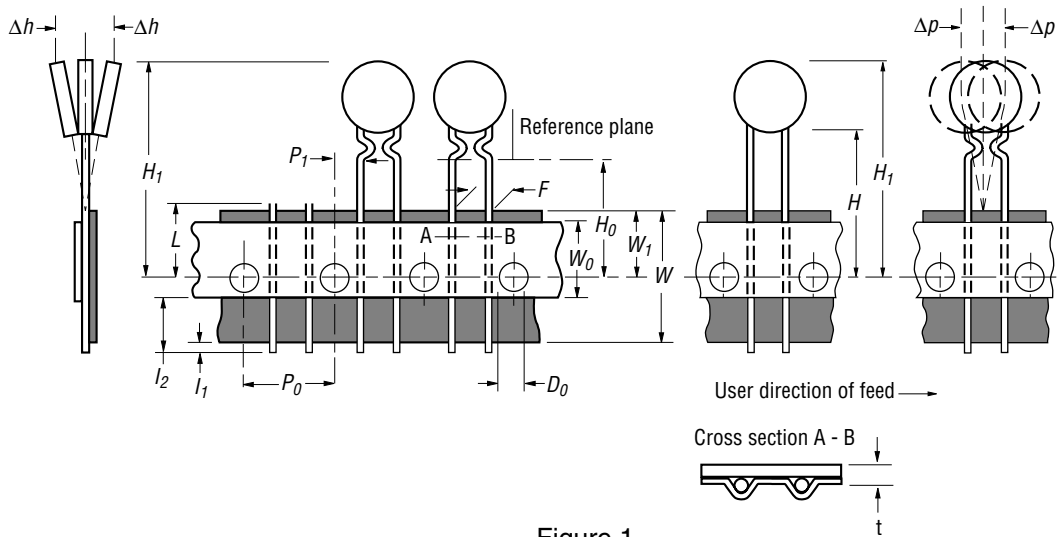

Figure 1

Reel Dimensions

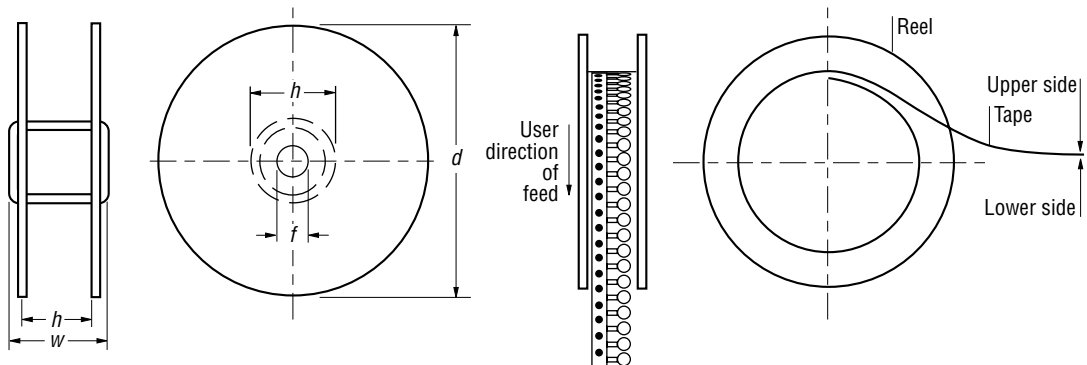

Figure 2