

2.00mm (0.079") PITCH CONNECTOR



Wire-to-Board
Wafer

20039WS Series

DIP

Straight

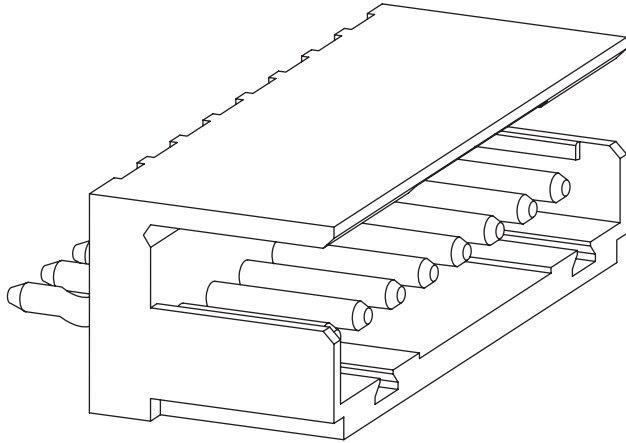

Material

I/NO	DESCRIPTION	TITLE	MATERIAL
1	WAFER	20039WS	PA66, UL 94V Grade
2	PIN		BRASS & Tin-Plated

Available Pin

PARTS NO.	A	B	C	D
20039WS-02A00	5.9	5.0	2.0	-
20039WS-03A00	7.9	7.0	4.0	-
20039WS-04A00	9.9	9.0	6.0	3.2
20039WS-05A00	11.9	11.0	8.0	5.2
20039WS-06A00	13.9	13.0	10.0	7.2
20039WS-07A00	15.9	15.0	12.0	9.2
20039WS-08A00	17.9	17.0	14.0	11.2
20039WS-09A00	19.9	19.0	16.0	13.2
20039WS-10A00	21.9	21.0	18.0	15.2
20039WS-11A00	23.9	23.0	20.0	17.2
20039WS-12A00	25.9	25.0	22.0	19.2
20039WS-13A00	27.9	27.0	24.0	21.2
20039WS-14A00	29.9	29.0	26.0	23.2
20039WS-15A00	31.9	31.0	28.0	25.2

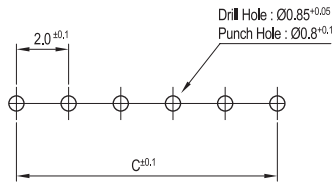
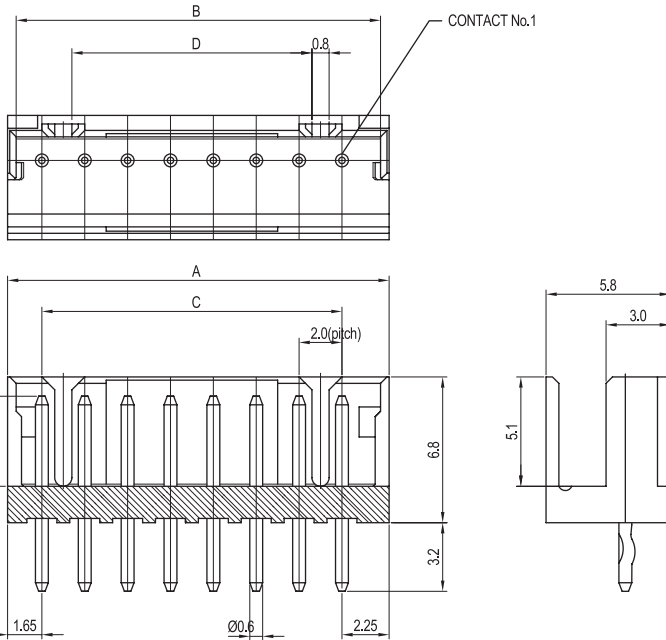

PCB LAYOUT

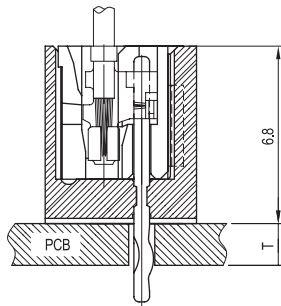

PCB ASS'Y

Specification

ITEM	SPEC
Voltage Rating	AC/DC 125V
Current Rating	AC/DC 3A
Operating Temperature	-25°C~+85°C
Contact Resistance	30mΩ MAX
Withstanding Voltage	AC1000V/1min
Insulation Resistance	1000MΩ MIN
Applicable Wire	-
Applicable P.C.B	1.2~1.6mm
Applicable FPC/FFC	-
Solder Height	-
Crimp Tensile Strength	-
UL FILE NO	-