

MIP708

Silicon MOS IC

■ Features

- 3-pin intelligent power device
- Five protective functions (over-current, over-voltage, short circuit load, over heat, ESD) built-in
- Acceptable both AC and DC power supply

■ Applications

- For lamp and solenoid drive

■ Absolute Maximum Ratings (Ta = 25°C)

Parameter	Symbol	Ratings	Unit
Output voltage	V_{DS}	40	V
Output peak current	I_{OP}	± 3	A
Output current	I_O	± 1	A
Input voltage	V_{IN}	-0.5 to 6	V
Input current	I_{IN}	± 5	mA
Drain clamp energy	E_{CLP}	24* ¹	mJ
Allowable power dissipation	Ta = 25°C	P_{D1}	1* ² W
	Tc = 25°C	P_{D2}	2 W
Operating ambient temperature	T_{opr}	-40 to +125	°C
Channel temperature	T_{ch}	150	°C
Storage temperature	T_{stg}	-55 to +150	°C

*¹ L = 10mH, $I_L = 2.19A$, $V_{DD} = 20V$, 1pulse, $T_C = 25^\circ C$

*² Mounting on the PCB (the copper foil of the drain portion has a area of 100mm² or more and the thickness of glass epoxy board is 1.7mm.)

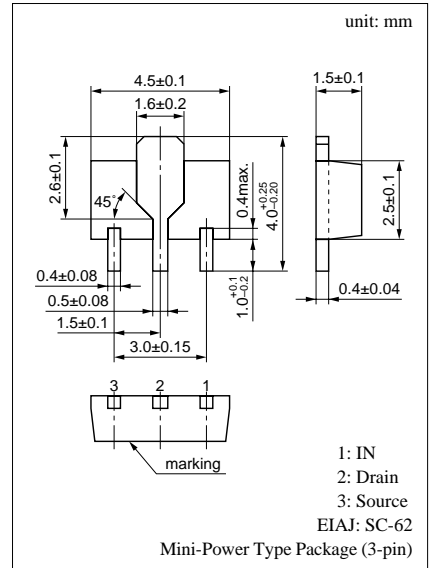

■ Block Diagram

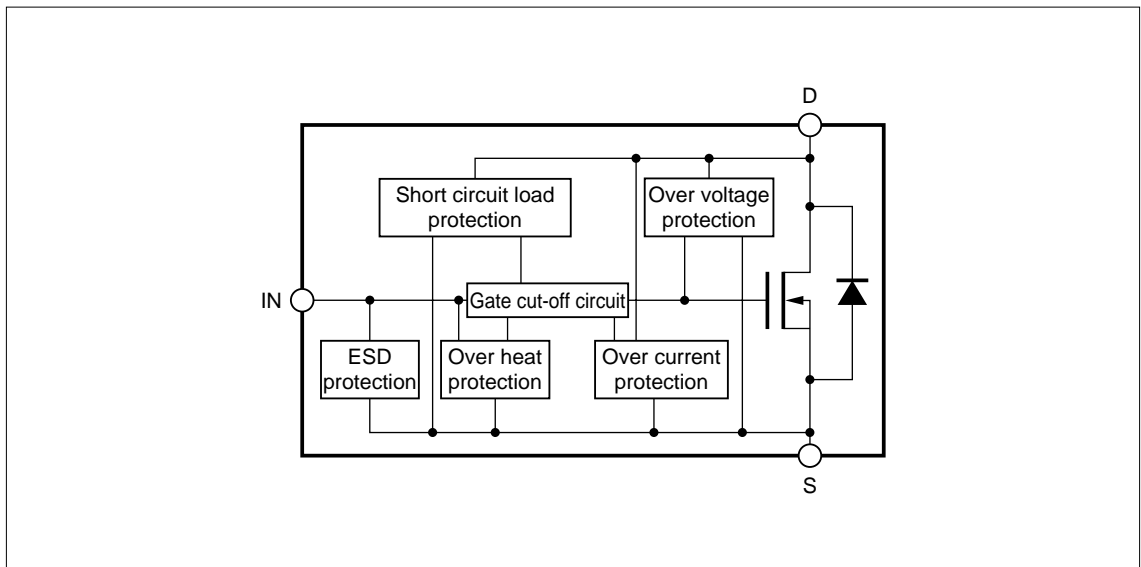

■ Electrical Characteristics ($T_C = 25 \pm 3^\circ\text{C}$)

Parameter	Symbol	Conditions	min	typ	max	Unit
Drain to Source ON-resistance	$R_{DS(on)}$	$V_{IN} = 5\text{V}, I_{DS} = 1\text{A}$		0.5	0.8	Ω
Drain to Source ON-voltage	$V_{DS(on)}$	$V_{IN} = 5\text{V}, I_{DS} = 1\text{A}$		0.5	0.8	V
Drain clamp voltage	$V_{DS(CLIP)}$	$V_{IN} = 0, I_{DS} = 3\text{mA}$	40	49		V
Drain OFF current (1)	$I_{DS(off)1}$	$V_{IN} = 0, V_{DS} = 12\text{V}$		50	100	μA
Drain OFF current (2)	$I_{DS(off)2}$	$V_{IN} = 0, V_{DS} = 16\text{V}$		70	140	mA
Input voltage (High)	$V_{IN(H)}$	$I_{DS} = 1\text{A}$	4			V
Input voltage (Low)	$V_{IN(L)}$	$I_{DS} = 1\text{mA}$			0.8	V
Input current	$I_{IN(on)}$	$V_{IN} = 5\text{V}, V_{DS} = 0$		0.15	1	mA
Over current protection limit	I_{OCP}	$V_{IN} = 5\text{V}$	2	3		A
Short circuit load protection limit	$V_{DS(SHT)}$	$V_{IN} = 5\text{V}$	2	4		V

Note: The oscillation of the output current is caused when the drain voltage exceeds the short circuit load detection voltage under the ON state of output.

■ Electrical Characteristics ($T_C = 25 \pm 2^\circ\text{C}$)

Parameter	Symbol	Conditions	min	typ	max	Unit
Over heat protection temperature	T_{SHD}	$V_{IN} = 5\text{V}$	160	190		$^\circ\text{C}$
Turn on delay time	$t_{d(on)}$	$V_{IN} = 5\text{V}, I_{DS} = 1\text{A}$		1		μs
Turn-on time	t_{on}			5.5		μs
Turn off delay time	$t_{d(off)}$	$V_{DD} = 12\text{V}, R_L = 12\Omega$		3.4		μs
Turn-off time	t_{off}			7.2		μs

Note 1: The above values of characteristics are not guaranteed values and are only references for designing.

Note 2: If the chip temperature exceeds the "Over Heat Protection Temperature", output current is shut down.

■ Timing Chart

