

NEW Product



- 18 A output current
- 12 V input voltage
- Wide-output voltage adjust
 - 1.2 Vdc to 5.5 Vdc for suffix 'W' and 0.8 Vdc to 1.8 Vdc for suffix 'L'
- Auto-track™ sequencing*
- Margin up/down controls
- Efficiencies up to 95%
- Output ON/OFF inhibit
- Output voltage sense
- Point-of-Load-Alliance (POLA) compatible
- Available RoHS compliant



The PTH12020 is a next generation series of non-isolated dc-dc converters offering some of the most advanced POL features available in the industry. The primary new feature provides for sequencing between multiple modules, a function, which is becoming a necessity for powering advanced silicon including DSP's, FPGA's and ASIC's requiring controlled power-up and power-down. Other industry leading features include margin up/down controls and efficiencies up to 95%. The PTH12020 has an input voltage of 10.8 Vdc to 13.2 Vdc and offers a wide output voltage range adjustable with external trim resistor, allowing for maximum design flexibility and a pathway for future upgrades.



All specifications are typical at nominal input, full load at 25 °C unless otherwise stated
 $C_{in} = 560 \mu F$, $C_{out} = 0 \mu F$

SPECIFICATIONS

OUTPUT SPECIFICATIONS		
Voltage adjustability (See Note 4)	Suffix 'W' Suffix 'L'	1.2-5.5 Vdc 0.8V-1.8 Vdc
Setpoint accuracy		±2.0% Vo
Line regulation		±5 mV typ.
Load regulation		±5 mV typ.
Total regulation		±3.0% Vo
Minimum load		0 A
Ripple and noise 20 MHz bandwidth	Suffix 'W' Suffix 'L'	32 mV pk-pk 1% Vo
Temperature co-efficient	-40 °C to +85 °C	±0.5% Vo
Transient response (See Note 5)		70 µs recovery time Overshoot/undershoot 130 mV
Margin adjustment		±5.0% Vo

INPUT SPECIFICATIONS		
Input voltage range	(See Note 3)	10.8-13.2 Vdc
Input current	No load	10 mA typ.
Remote ON/OFF	(See Note 1)	Positive logic
Start-up time		1 V/ms
Undervoltage lockout		9.2-9.7 V typ.
Track input voltage	Pin 8 (See Note 6)	±0.3 Vin

EMC CHARACTERISTICS		
Electrostatic discharge		EN61000-4-2, IEC801-2
Conducted immunity		EN61000-4-6
Radiated immunity		EN61000-4-3

GENERAL SPECIFICATIONS		
Efficiency		See Efficiency Table on page 2
Insulation voltage		Non-isolated
Switching frequency	Suffix 'W' Suffix 'L'	260 kHz to 380 kHz 200 kHz to 300 kHz
Approvals and standards		EN60950 UL/cUL60950
Material flammability		UL94V-0
Dimensions	(L x W x H)	37.97 x 22.10 x 9.00 mm 1.495 x 0.870 x 0.354 in
Weight		7 g (0.25 oz)
MTBF	Telcordia SR-332	5,236,000 hours

ENVIRONMENTAL SPECIFICATIONS		
Thermal performance (See Note 2)	Operating ambient, temperature Non-operating	-40 °C to +85 °C -40 °C to +125 °C
MSL ('Z' suffix only)	JEDEC J-STD-020C	Level 3

PROTECTION		
Short-circuit	Auto reset	30 A typ.
Thermal		Auto recovery

International Safety Standard Approvals



UL/cUL CAN/CSA-C22.2 No. 60950-1-03/UL 60950-1, File No. E174104



TÜV Product Service (EN60950) Certificate No. B 04 06 38572 044
 CB Report and Certificate to IEC60950, Certificate No. US/8292/UL

*Auto-track™ is a trade mark of Texas Instruments

OUTPUT POWER (MAX.)	INPUT VOLTAGE	OUTPUT VOLTAGE	OUTPUT CURRENT (MIN.)	OUTPUT CURRENT (MAX.)	EFFICIENCY (MAX.)	REGULATION		MODEL NUMBER ^(8,9)
						LINE	LOAD	
99 W	10.8-13.2 Vdc	0.8-1.8 Vdc	0 A	18 A	89%	±5 mV	±5 mV	PTH12020L
99 W	10.8-13.2 Vdc	1.2-5.5 Vdc	0 A	18 A	95%	±5 mV	±5 mV	PTH12020W

Part Number System with Options

PTH12020WAST

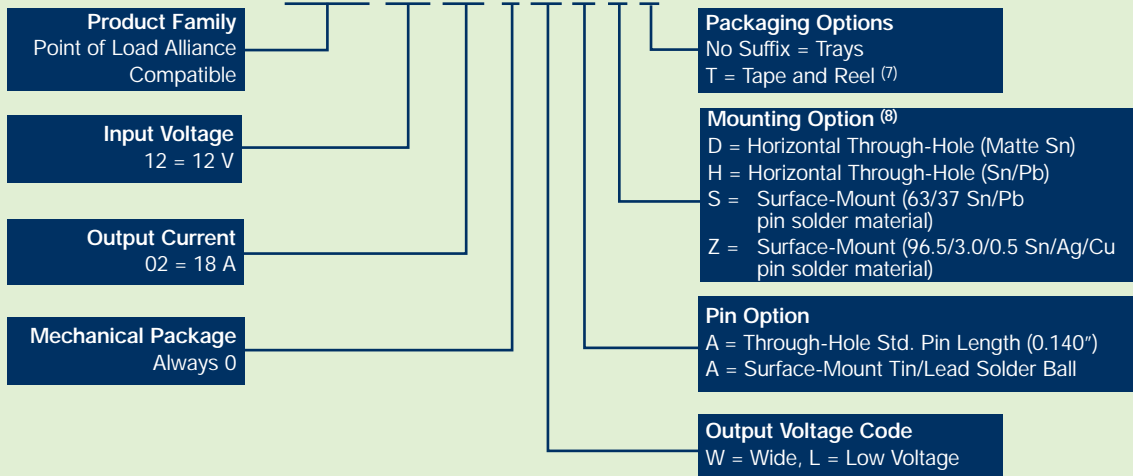

Output Voltage Adjustment of the PTH12020 Series

The ultra-wide output voltage trim range offers major advantages to users who select the PTH12020. It is no longer necessary to purchase a variety of modules in order to cover different output voltages. The output voltage can be trimmed in a range of 1.2 Vdc to 5.5 Vdc. When the PTH12020 converter leaves the factory the output has been adjusted to the default voltage of 1.2 V.

EFFICIENCY TABLE - PTH12020W(I_O = 18 A)

OUTPUT VOLTAGE	EFFICIENCY
Vo = 5.0 V	95%
Vo = 3.3 V	93%
Vo = 2.5 V	92%
Vo = 1.8 V	90%
Vo = 1.5 V	88%
Vo = 1.2 V	86%

EFFICIENCY TABLE - PTH12020L (I_O = 18 A)

OUTPUT VOLTAGE	EFFICIENCY
Vo = 1.8 V	89%
Vo = 1.5 V	87%
Vo = 1.2 V	85%
Vo = 1.0 V	83%
Vo = 0.8 V	80%

Notes

- Remote ON/OFF. Positive Logic
ON: Pin 3 open; or V > Vin - 0.5 V
OFF: Pin 3 GND; or V < 0.8 V (min - 0.2 V).
- See Figures 1, 2 and 3 for safe operating curves.
- A 560 µF electrolytic input capacitor is required for proper operation. The capacitor must be rated for a minimum of 800 mA rms of ripple current.
- An external output capacitor is not required for basic operation. Adding 330 µF of distributed capacitance at the load will improve the transient response.
- 1 A/µs load step, 50 to 100% I_{o,max}, C_{out} = 330 µF.
- If utilized V_{out} will track applied voltage by ±0.3 V (up to V_o set point).
- Tape and reel packaging only available on the surface-mount versions.
- To order Pb-free (RoHS compatible) surface-mount parts replace the mounting option 'S' with 'Z', e.g. PTH12020WAZ. To order Pb-free (RoHS compatible) through-hole parts replace the mounting option 'H' with 'D', e.g. PTH12020WAD.
- NOTICE: Some models do not support all options. Please contact your local Artesyn representative or use the on-line model number search tool at <http://www.artesyn.com/powergroup/products.htm> to find a suitable alternative.

PTH12020W Characteristic Data

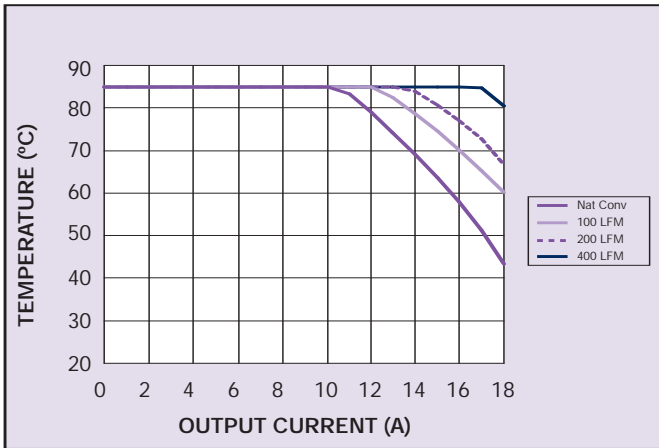

Figure 1 - Safe Operating Area
Vin = 12 V, Output Voltage = 5 V (See Note A)

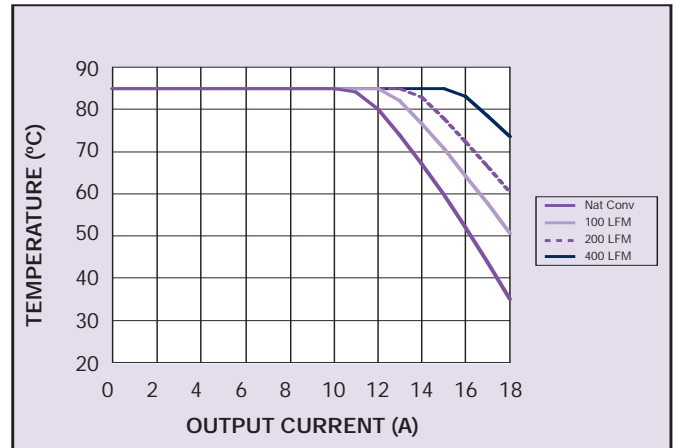

Figure 2 - Safe Operating Area
Vin = 12 V, Output Voltage = 3.3 V (See Note A)

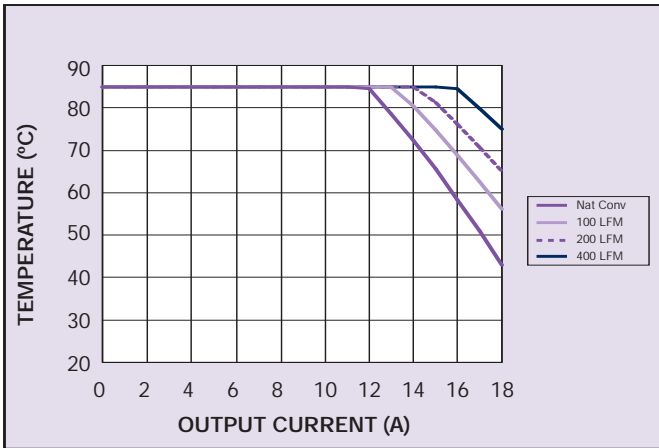

Figure 3 - Safe Operating Area
Vin = 12 V, Output Voltage = 1.8 V (See Note A)

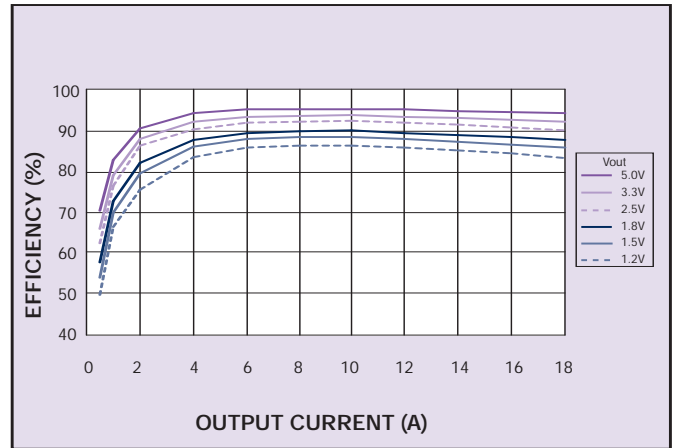

Figure 4 - Efficiency vs Load Current
Vin = 12 V (See Note B)

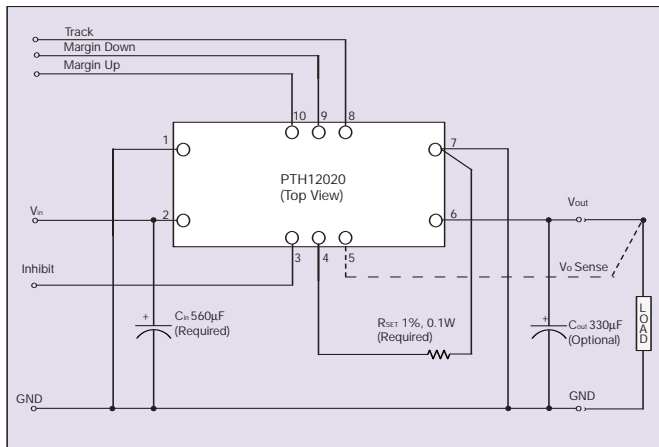

Figure 5 - Standard Application

Notes

- A SOA curves represent the conditions at which internal components are within the Artesyn derating guidelines.
- B Characteristic data has been developed from actual products tested at 25 °C. This data is considered typical data for the converter.

PTH12020L Characteristic Data

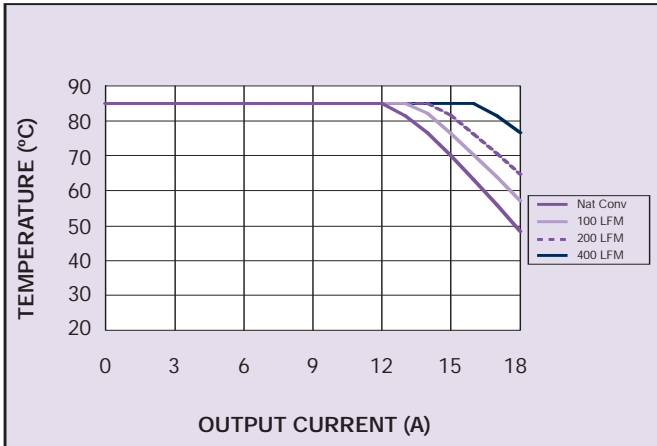

Figure 6 - Safe Operating Area for PTH12020L
Vin = 12 V, Output Voltage = 1.8 V (See Note A)

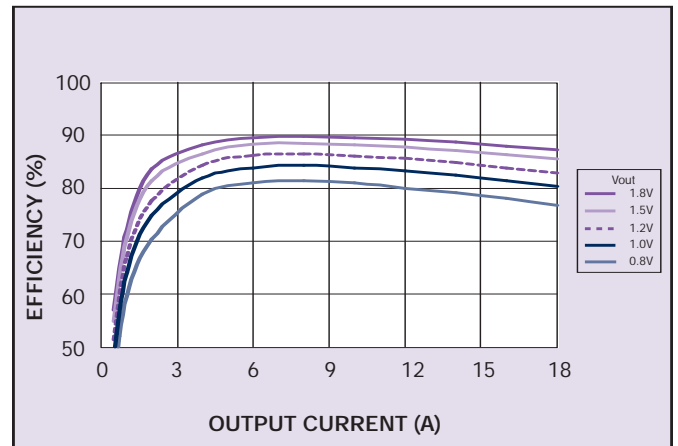

Figure 7 - Efficiency vs Load Current for PTH12020L
Vin = 12 V (See Note B)

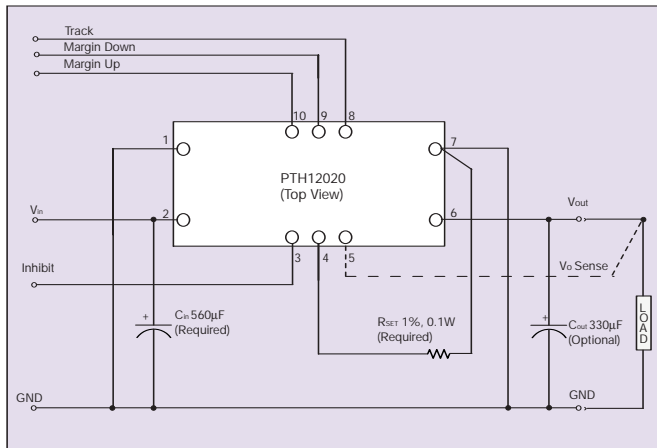

Figure 8 - Standard Application

Notes

- A SOA curves represent the conditions at which internal components are within the Artesyn derating guidelines.
- B Characteristic data has been developed from actual products tested at 25 °C. This data is considered typical data for the converter.

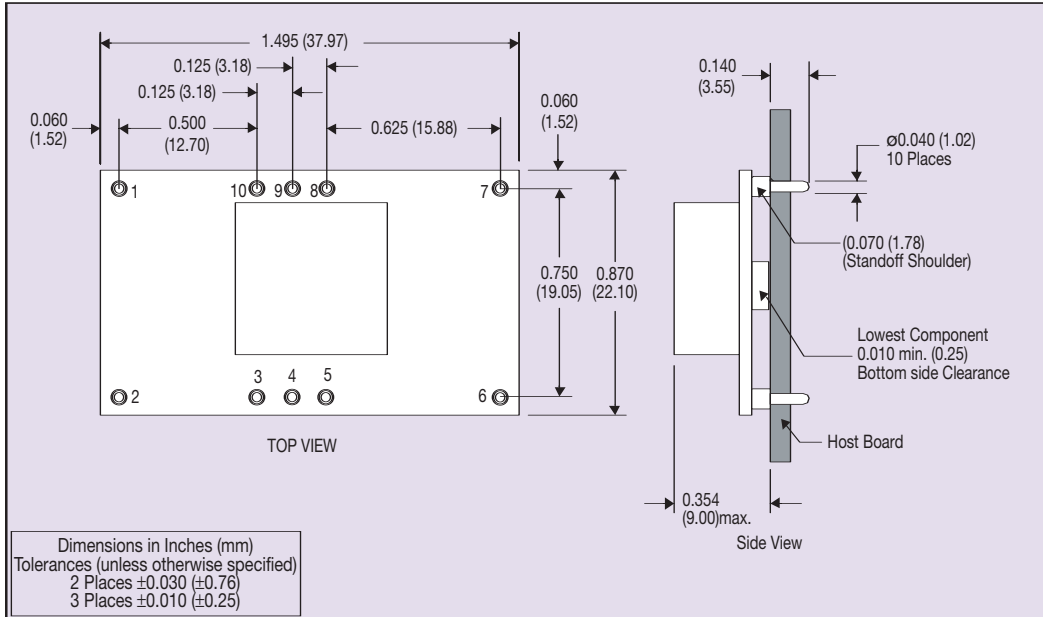

Figure 9 - Plated Through-Hole Mechanical Drawing

PIN CONNECTIONS	
PIN NO.	FUNCTION
1	Ground
2	Vin
3	Inhibit*
4	Vo adjust
5	Vo sense
6	Vout
7	Ground
8	Track
9	Margin down*
10	Margin up*

*Denotes negative logic:
Open = Normal operation
Ground = Function active

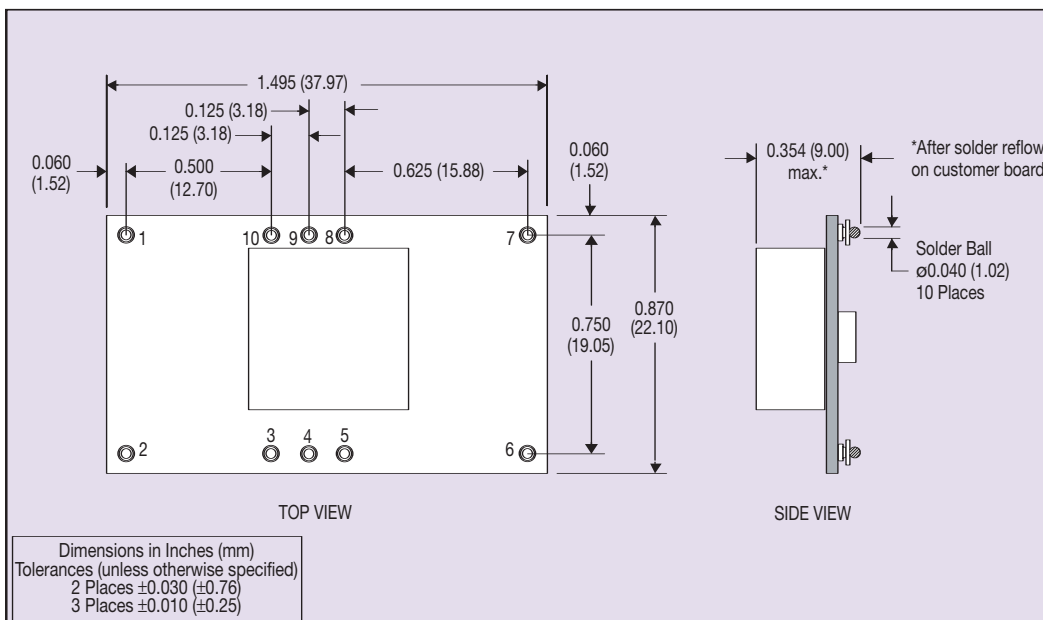

Figure 10 - Surface-Mount Mechanical Drawing