

3.3V 20Mbps RS485/RS422 Transceivers with Integrated Switchable Termination

FEATURES

- Integrated, Logic-Selectable 120Ω Termination Resistor
- 3.3V Supply Voltage
- 20Mbps Maximum Data Rate
- No Damage or Latchup Up to ±25kV HBM
- High Input Impedance Supports 256 Nodes
- Guaranteed Failsafe Receiver Operation Over the Entire Common Mode Range
- Current Limited Drivers and Thermal Shutdown
- Delayed Micropower Shutdown: 5μA Maximum
- Power Up/Down Glitch-Free Driver Outputs
- Low Operating Current: 370μA Typical in Receive Mode
- Compatible with TIA/EIA-485-A Specifications
- Available in 10-Pin 3mm × 3mm DFN, 12-Pin 4mm × 3mm DFN and 16-Pin SSOP Packages

APPLICATIONS

- Low Power RS485/RS422 Transceiver
- Level Translator
- Backplane Transceiver

LT, LT, LTC and LTM are registered trademarks of Linear Technology Corporation. All other trademarks are the property of their respective owners.

DESCRIPTION

The LTC[®]2854 and LTC2855 are low power, 20Mbps RS485/RS422 transceivers operating on 3.3V supplies. The receiver includes a logic-selectable 120Ω termination, one-eighth unit load supporting up to 256 nodes per bus, and a failsafe feature that guarantees a high output state under conditions of floating or shorted inputs.

The driver maintains a high output impedance over the entire common mode range when disabled or when the supply is removed. Excessive power dissipation caused by bus contention or a fault is prevented by current limiting all outputs and by a thermal shutdown.

Enhanced ESD protection allows the LTC2854 to withstand ±25kV (human body model) and the LTC2855 to withstand ±15kV on the transceiver interface pins without latchup or damage.

PRODUCT SELECTION GUIDE

PART NUMBER	DUPLEX	PACKAGE
LTC2854	HALF	DFN-10
LTC2855	FULL	SSOP-16, DFN-12

TYPICAL APPLICATION

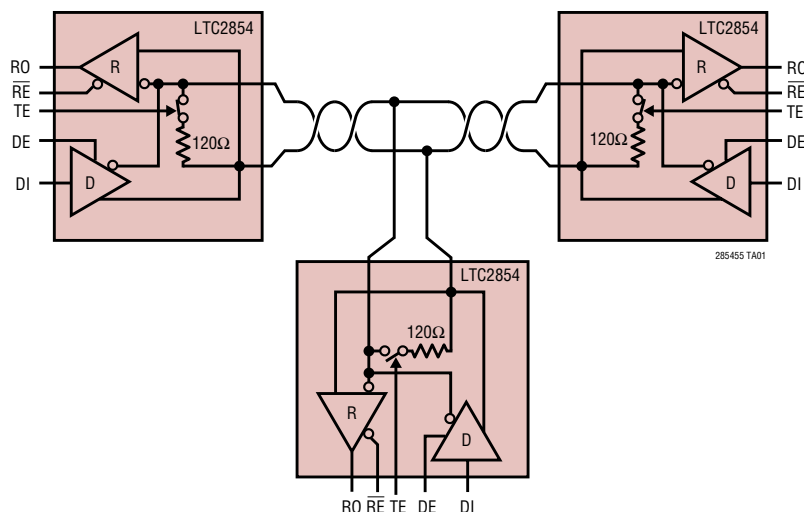

LTC2854 at 20Mbps into 54Ω

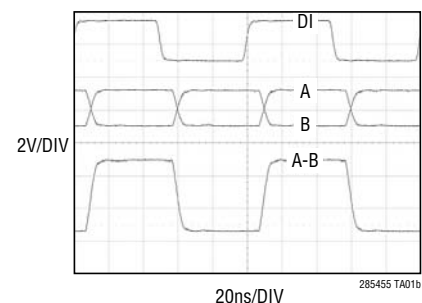

LTC2854/LTC2855

ABSOLUTE MAXIMUM RATINGS (Note 1)

Supply Voltage (V_{CC})	-0.3V to 7V	Operating Temperature (Note 4)	
Logic Input Voltages (\overline{RE} , DE, DI, TE)	-0.3V to 7V	LTC2854C, LTC2855C	0°C to 70°C
Interface I/O:		LTC2854I, LTC2855I	-40°C to 85°C
A, B, Y, Z	($V_{CC}-15V$) to +15V	Storage Temperature Range	-65°C to 125°C
(A-B) or (B-A) with Terminator Enabled	6V	Lead Temperature (Soldering, 10 sec)	
Receiver Output Voltage (RO)	-0.3V to ($V_{CC}+0.3V$)	GN Package	300°C

PACKAGE/ORDER INFORMATION

<p>DD PACKAGE 10-LEAD (3mm x 3mm) PLASTIC DFN EXPOSED PAD (PIN 11) PCB GND CONNECTION $T_{JMAX} = 125^{\circ}C$, $\theta_{JA} = 43^{\circ}C/W$ $\theta_{JC} = 2.96^{\circ}C/W$</p>		<p>DE PACKAGE 12-LEAD (4mm x 3mm) PLASTIC DFN EXPOSED PAD (PIN 13) PCB GND CONNECTION $T_{JMAX} = 125^{\circ}C$, $\theta_{JA} = 44^{\circ}C/W$ $\theta_{JC} = 4.3^{\circ}C/W$</p>		<p>GN PACKAGE 16-LEAD (NARROW 0.150) PLASTIC SSOP $T_{JMAX} = 125^{\circ}C$, $\theta_{JA} = 110^{\circ}C/W$ $\theta_{JC} = 40^{\circ}C/W$</p>	
ORDER PART NUMBER	DD PART* MARKING	ORDER PART NUMBER	DE PART* MARKING	ORDER PART NUMBER	GN PART MARKING
LTC2854CDD LTC2854IDD	LCQG LCQG	LTC2855CDE LTC2855IDE	2855 2855	LTC2855CGN LTC2855IGN	2855 2855I
Order Options Tape and Reel: Add #TR Lead Free: Add #PBF Lead Free Tape and Reel: Add #TRPBF Lead Free Part Marking: http://www.linear.com/leadfree/					

Consult LTC Marketing for parts specified with wider operating temperature ranges. *The temperature grade is identified by a label on the shipping container.

ELECTRICAL CHARACTERISTICS

The ● denotes the specifications which apply over the full operating temperature range, otherwise specifications are at $T_A = 25^\circ\text{C}$, $V_{CC} = 3.3\text{V}$ unless otherwise noted (Note 2).

SYMBOL	PARAMETER	CONDITIONS	MIN	TYP	MAX	UNITS
Driver						
$ V_{OD} $	Differential Driver Output Voltage	$R = \infty$, $V_{CC} = 3\text{V}$ (Figure 1) $R = 27\Omega$, $V_{CC} = 3\text{V}$ (Figure 1) $R = 50\Omega$, $V_{CC} = 3.13\text{V}$ (Figure 1)	● ● ●	1.5 2	V_{CC} V_{CC} V_{CC}	V V V
$\Delta V_{OD} $	Change in Magnitude of Driver Differential Output Voltage for Complementary Output States	$R = 27\Omega$ or $R = 50\Omega$ (Figure 1)	●		0.2	V
V_{OC}	Driver Common Mode Output Voltage	$R = 27\Omega$ or $R = 50\Omega$ (Figure 1)	●		3	V
$\Delta V_{OC} $	Change in Magnitude of Driver Common Mode Output Voltage for Complementary Output States	$R = 27\Omega$ or $R = 50\Omega$ (Figure 1)	●		0.2	V
I_{OZD}	Driver Three-State (High Impedance) Output Current on Y and Z	$DE = 0\text{V}$, (Y or Z) = -7V , $+12\text{V}$ (LTC2855)	●		± 10	μA
I_{OSD}	Maximum Driver Short-Circuit Current	$-7\text{V} \leq (\text{Y or Z}) \leq 12\text{V}$ (Figure 2)	● ●	180 -250	± 250 300	mA mA
Receiver						
I_{IN}	Receiver Input Current (A, B)	$DE = TE = 0\text{V}$, $V_{CC} = 0\text{V}$ or 3.3V , $V_{IN} = 12\text{V}$ (Figure 3) $DE = TE = 0\text{V}$, $V_{CC} = 0\text{V}$ or 3.3V , $V_{IN} = -7\text{V}$, (Figure 3)	● ●		125	μA μA
R_{IN}	Receiver Input Resistance	$\overline{RE} = V_{CC}$ or 0V , $DE = TE = 0\text{V}$, $V_{IN} = -7\text{V}$, -3V , $+3\text{V}$, $+7\text{V}$, $+12\text{V}$ (Figure 3)	●	96	125	$\text{k}\Omega$
V_{TH}	Receiver Differential Input Threshold Voltage	$-7\text{V} \leq B \leq 12\text{V}$	●		± 0.2	V
ΔV_{TH}	Receiver Input Hysteresis	$B = 0\text{V}$		25		mV
V_{OH}	Receiver Output HIGH Voltage	$I(RO) = -4\text{mA}$, $A-B = 200\text{mV}$, $V_{CC} = 3\text{V}$	●	2.4		V
V_{OL}	Receiver Output LOW Voltage	$I(RO) = 4\text{mA}$, $A-B = -200\text{mV}$, $V_{CC} = 3\text{V}$	●		0.4	V
I_{OZR}	Receiver Three-State (High Impedance) Output Current on RO	$\overline{RE} = V_{CC}$, $0\text{V} \leq RO \leq V_{CC}$	●		± 1	μA
I_{OSR}	Receiver Short-Circuit Current	$0\text{V} \leq RO \leq V_{CC}$	●		± 85	mA
R_{TERM}	Receiver Input Terminating Resistor	$TE = V_{CC}$, $V_{AB} = 2\text{V}$, $V_B = -7\text{V}$, 0V , 10V (Figure 8)	●	108	120	156 Ω
Logic						
V_{IH}	Logic Input High Voltage	$V_{CC} = 3.6\text{V}$	●	2		V
V_{IL}	Logic Input Low Voltage	$V_{CC} = 3\text{V}$	●		0.8	V
I_{INL}	Logic Input Current		●	0	± 10	μA
Supplies						
I_{CCS}	Supply Current in Shutdown Mode	$DE = 0\text{V}$, $\overline{RE} = V_{CC}$, $TE = 0\text{V}$	●	0	5	μA
I_{CCR}	Supply Current in Receive Mode	$DE = 0\text{V}$, $\overline{RE} = 0\text{V}$, $TE = 0\text{V}$	●	370	900	μA
I_{CCT}	Supply Current in Transmit Mode	No Load, $DE = V_{CC}$, $\overline{RE} = V_{CC}$, $TE = 0\text{V}$	●	450	1000	μA
I_{CCTR}	Supply Current with Both Driver and Receiver Enabled	No Load, $DE = V_{CC}$, $\overline{RE} = 0\text{V}$, $TE = 0\text{V}$	●	450	1000	μA
I_{CCTERM}	Supply Current in Termination Mode	$DE = 0\text{V}$, $\overline{RE} = V_{CC}$, $TE = V_{CC}$	●	110	180	μA
$I_{CCTERM R}$	Supply Current in Receive and Termination Mode	$DE = 0\text{V}$, $\overline{RE} = 0\text{V}$, $TE = V_{CC}$	●	450	950	μA

ELECTRICAL CHARACTERISTICS

The ● denotes the specifications which apply over the full operating temperature range, otherwise specifications are at $T_A = 25^\circ\text{C}$, $V_{CC} = 3.3\text{V}$, $T_E = 0\text{V}$ unless otherwise noted (Note 2).

SYMBOL	PARAMETER	CONDITIONS	MIN	TYP	MAX	UNITS
I_{CCTERM}	Supply Current in Transmit and Termination Mode	$DE = V_{CC}$, $\overline{RE} = V_{CC}$, $TE = V_{CC}$	●	470	1000	μA
$I_{CCTERMTR}$	Supply Current with Driver, Receiver and Termination Enabled	$DE = V_{CC}$, $\overline{RE} = 0\text{V}$, $TE = V_{CC}$	●	470	1000	μA

ESD Protection

	ESD Protection for RS485/RS422 Pins	A, B on LTC2854, Human Body Model Y, Z, A, B on LTC2855, Human Body Model		± 25		kV
				± 15		kV

SWITCHING CHARACTERISTICS

The ● denotes the specifications which apply over the full operating temperature range, otherwise specifications are at $T_A = 25^\circ\text{C}$, $V_{CC} = 3.3\text{V}$, $T_E = 0\text{V}$ unless otherwise noted (Note 2).

SYMBOL	PARAMETER	CONDITIONS	MIN	TYP	MAX	UNITS
Driver						
f_{MAX}	Maximum Data Rate	Note 3	●	20		Mbps
t_{PLHD} , t_{PHLD}	Driver Input to Output	$R_{DIFF} = 54\Omega$, $C_L = 100\text{pF}$ (Figure 4)	●	10	50	ns
Δt_{PD}	Driver Input to Output Difference $ t_{PLHD} - t_{PHLD} $	$R_{DIFF} = 54\Omega$, $C_L = 100\text{pF}$ (Figure 4)	●	1	6	ns
t_{SKEWD}	Driver Output Y to Output Z	$R_{DIFF} = 54\Omega$, $C_L = 100\text{pF}$ (Figure 4)	●	1	± 6	ns
t_{RD} , t_{FD}	Driver Rise or Fall Time	$R_{DIFF} = 54\Omega$, $C_L = 100\text{pF}$ (Figure 4)	●	4	12.5	ns
t_{ZLD} , t_{ZHD} , t_{LZD} , t_{HZD}	Driver Enable or Disable Time	$R_L = 500\Omega$, $C_L = 50\text{pF}$, $\overline{RE} = 0$ (Figure 5)	●		70	ns
t_{ZHSD} , t_{ZLSD}	Driver Enable from Shutdown	$R_L = 500\Omega$, $C_L = 50\text{pF}$, $\overline{RE} = V_{CC}$ (Figure 5)	●		8	μs
t_{SHDN}	Time to Shutdown	$(DE = \overline{1}, \overline{RE} = V_{CC})$ or $(DE = 0, \overline{RE} = \overline{1})$ (Figure 5)	●		100	ns
Receiver						
t_{PLHR} , t_{PHLR}	Receiver Input to Output	$C_L = 15\text{pF}$, $V_{CM} = 1.5\text{V}$, $ V_{AB} = 1.5\text{V}$, t_R and $t_F < 4\text{ns}$ (Figure 6)	●	50	70	ns
t_{SKEWR}	Differential Receiver Skew $ t_{PLHR} - t_{PHLR} $	$C_L = 15\text{pF}$ (Figure 6)	●	1	6	ns
t_{RR} , t_{FR}	Receiver Output Rise or Fall Time	$C_L = 15\text{pF}$ (Figure 6)	●	3	12.5	ns
t_{ZLR} , t_{ZHR} , t_{LZR} , t_{HZR}	Receiver Enable/Disable	$R_L = 1\text{k}$, $C_L = 15\text{pF}$, $DE = V_{CC}$ (Figure 7)	●		50	ns
t_{ZHSR} , t_{ZLSR}	Receiver Enable from Shutdown	$R_L = 1\text{k}$, $C_L = 15\text{pF}$, $DE = 0\text{V}$ (Figure 7)	●		8	μs
t_{RTEN} , t_{RTZ}	Termination Enable or Disable Time	$V_B = 0\text{V}$, $V_{AB} = 2\text{V}$, $\overline{RE} = V_{CC}$, $DE = 0\text{V}$ (Figure 8)	●		100	μs

Note 1: Stresses beyond those listed under Absolute Maximum Ratings may cause permanent damage to the device. Exposure to any Absolute Maximum Rating condition for extended periods may affect device reliability and lifetime.

Note 2: All currents into device pins are positive; all currents out of device pins are negative. All voltages are referenced to device ground unless otherwise specified.

Note 3: Maximum data rate is guaranteed by other measured parameters and is not tested directly.

Note 4: This IC includes overtemperature protection that is intended to protect the device during momentary overload conditions. Junction temperature will exceed 125°C when overtemperature protection is active. Continuous operation above the specified maximum operating junction temperature may result in device degradation or failure.

TEST CIRCUITS

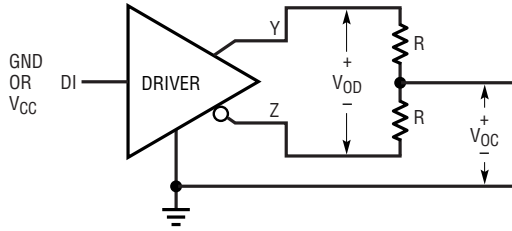

Figure 1. Driver DC Characteristics

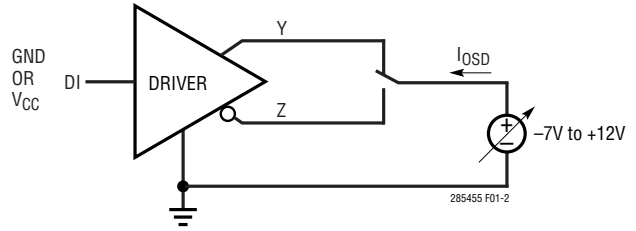

Figure 2. Driver Output Short-Circuit Current

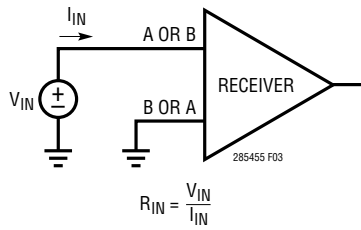

Figure 3. Receiver Input Current and Input Resistance

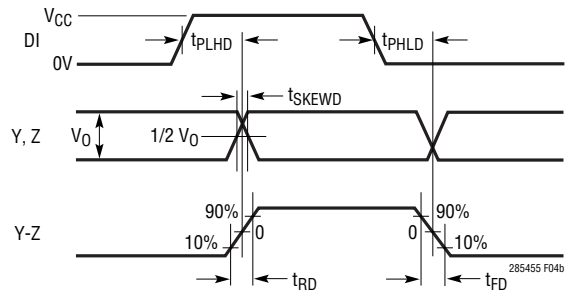
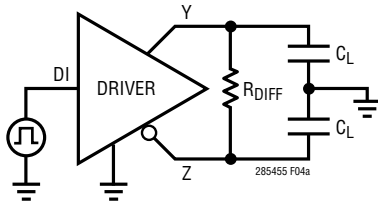

Figure 4. Driver Timing Measurement

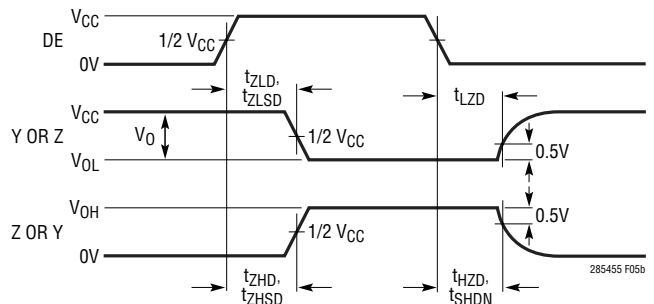
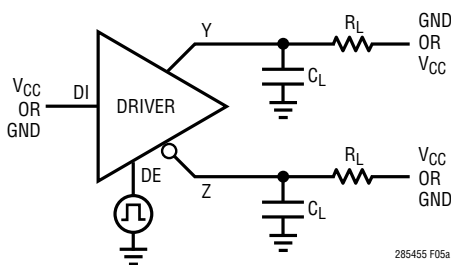

Figure 5. Driver Enable and Disable Timing Measurements

TEST CIRCUITS

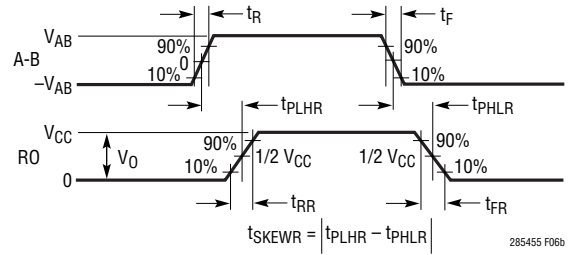
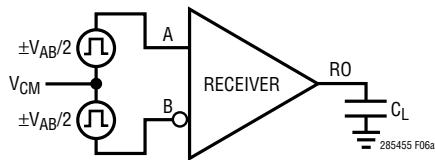

Figure 6. Receiver Propagation Delay Measurements

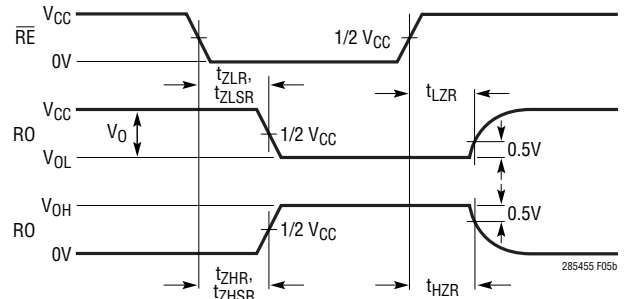
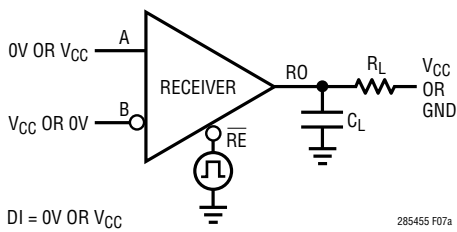
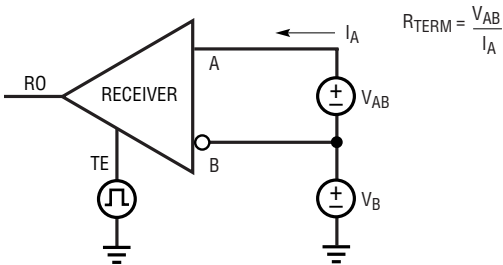

Figure 7. Receiver Enable and Disable Timing Measurements



$$R_{TERM} = \frac{V_{AB}}{I_A}$$

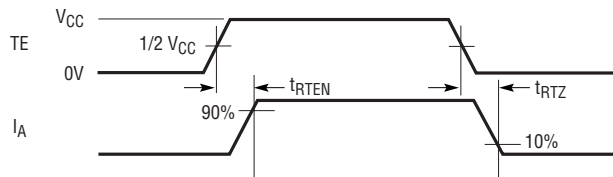
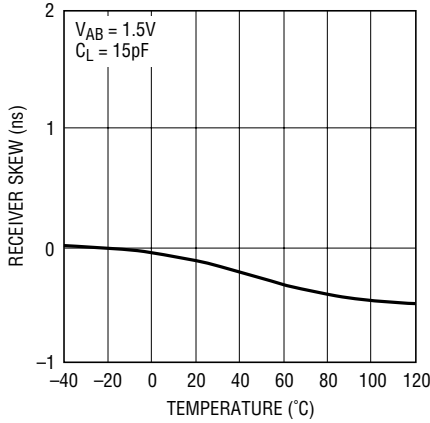

Figure 8. Termination Resistance and Timing Measurements

TYPICAL PERFORMANCE CHARACTERISTICS $T_A = 25^\circ\text{C}$, $V_{CC} = 3.3\text{V}$, unless otherwise noted.

Receiver Skew vs Temperature



285455 G01

Driver Skew vs Temperature

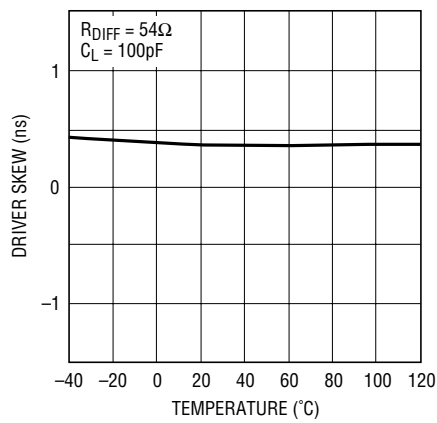

285455 G02

Driver Propagation Delay vs Temperature

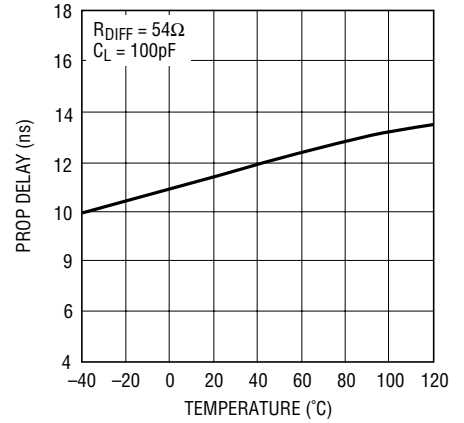

285455 G03

R_{TERM} vs Temperature

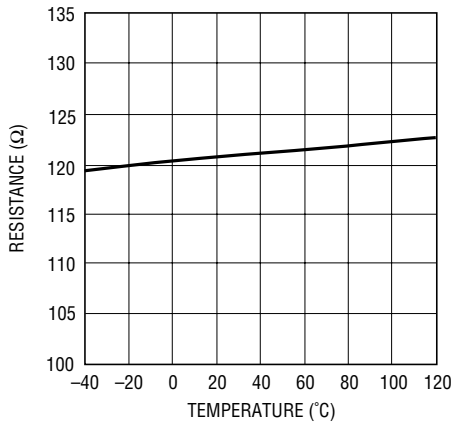

285455 G04

Driver Output Low/High Voltage vs Output Current

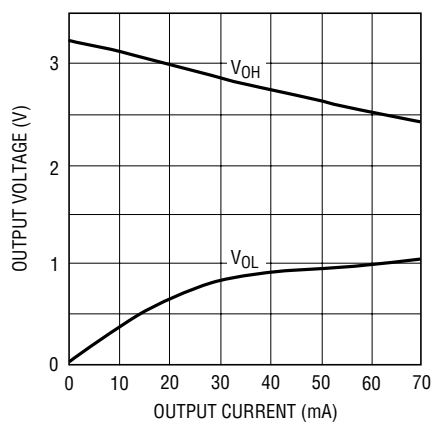

285455 G05

Driver Differential Output Voltage vs Temperature

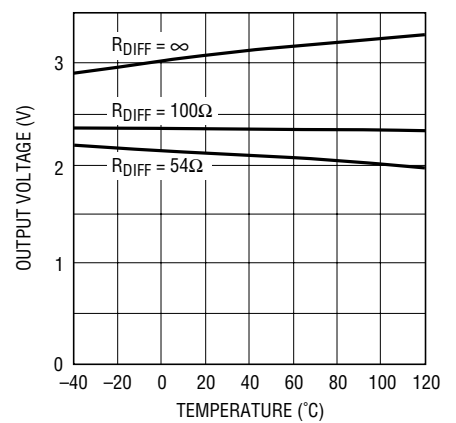

285455 G06

Receiver Output Voltage vs Output Current (Source and Sink)

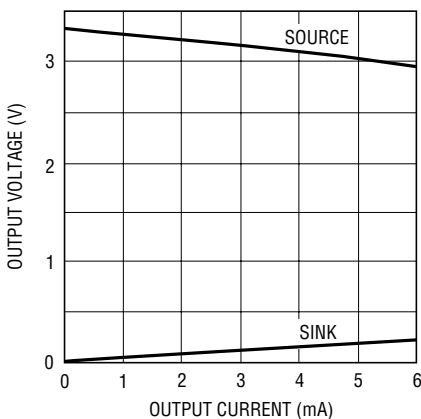

285455 G07

Receiver Propagation Delay vs Temperature

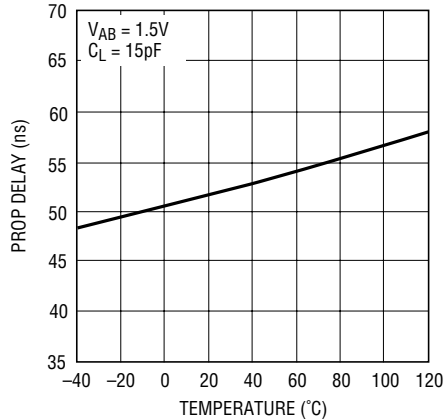

285455 G08

Supply Current vs Data Rate

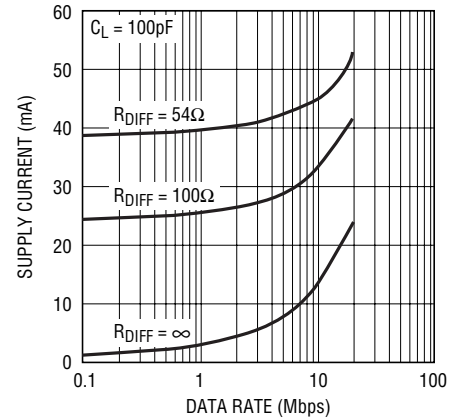

285455 G09

PIN FUNCTIONS (DD/DE/GN)

RO (Pin 1): Receiver Output. If the receiver output is enabled (\overline{RE} low) and $A > B$ by 200mV, then RO will be high. If $A < B$ by 200mV, then RO will be low. If the receiver inputs are open, shorted, or terminated without a signal, RO will be high.

\overline{RE} (Pin 2): Receiver Enable. A low enables the receiver. A high input forces the receiver output into a high impedance state.

DE (Pin 3): Driver Enable. A high on DE enables the driver. A low input will force the driver outputs into a high impedance. If \overline{RE} is high with DE and TE low, the part will enter a low power shutdown state.

DI (Pin 4): Driver Input. If the driver outputs are enabled (DE high), then a low on DI forces the driver positive output low and negative output high. A high on DI, with the driver outputs enabled, forces the driver positive output high and negative output low.

TE (Pin 5): Internal Termination Resistance Enable. A high input will connect a termination resistor (120 Ω typical) between pins A and B.

GND (Pins 6,11/6,13/6): Ground. Pins 11 and 13 are backside thermal pad, connected to Ground.

Y (Pins NA/8/12): Positive Driver Output for LTC2855.

Z (Pins NA/9/13): Negative Driver Output for LTC2855.

B (Pins 9/10/14): Negative Receiver Input (and Negative Driver Output for LTC2854).

A (Pins 8/11/15): Positive Receiver Input (and Positive Driver Output for LTC2854).

V_{CC} (Pins 10/12/16): Positive Supply. $V_{CC} = 3.0V < V_{CC} < 3.6V$. Bypass with 0.1 μ F ceramic capacitor.

FUNCTION TABLES

LTC2854

LOGIC INPUTS			MODE	A, B	RO	TERMINATOR
DE	\overline{RE}	TE				
0	0	0	RECEIVE	R_{IN}	DRIVEN	OFF
0	0	1	RECEIVE WITH TERM	R_{TERM}	DRIVEN	ON
0	1	0	SHUTDOWN	R_{IN}	HIGH-Z	OFF
0	1	1	TERM ONLY	R_{TERM}	HIGH-Z	ON
1	0	0	TRANSMIT WITH RECEIVE	DRIVEN	DRIVEN	OFF
1	0	1	TRANSMIT WITH RECEIVE AND TERM	DRIVEN	DRIVEN	ON
1	1	0	TRANSMIT	DRIVEN	HIGH-Z	OFF
1	1	1	TRANSMIT WITH TERM	DRIVEN	HIGH-Z	ON

LTC2855

LOGIC INPUTS			MODE	A, B	Y, Z	RO	TERMINATOR
DE	\overline{RE}	TE					
0	0	0	RECEIVE	R_{IN}	HIGH-Z	DRIVEN	OFF
0	0	1	RECEIVE WITH TERM	R_{TERM}	HIGH-Z	DRIVEN	ON
0	1	0	SHUTDOWN	R_{IN}	HIGH-Z	HIGH-Z	OFF
0	1	1	TERM ONLY	R_{TERM}	HIGH-Z	HIGH-Z	ON
1	0	0	TRANSMIT WITH RECEIVE	R_{IN}	DRIVEN	DRIVEN	OFF
1	0	1	TRANSMIT WITH RECEIVE AND TERM	R_{TERM}	DRIVEN	DRIVEN	ON
1	1	0	TRANSMIT	R_{IN}	DRIVEN	HIGH-Z	OFF
1	1	1	TRANSMIT WITH TERM	R_{TERM}	DRIVEN	HIGH-Z	ON

BLOCK DIAGRAMS

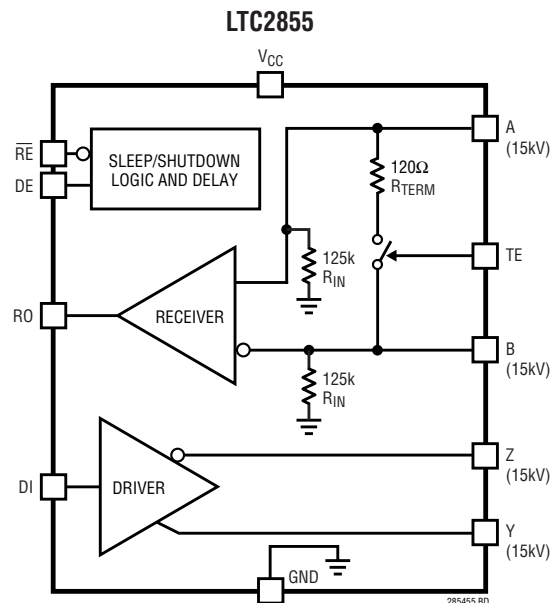
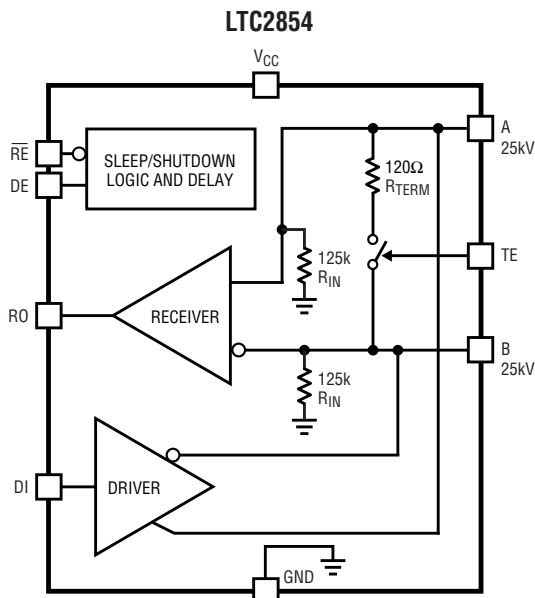

285455f

APPLICATIONS INFORMATION

Driver

The driver provides full RS485/RS422 compatibility. When enabled, if DI is high, Y-Z is positive for the full-duplex device (LTC2855) and A-B is positive for the half-duplex device (LTC2854).

When the driver is disabled, both outputs are high-impedance. For the full-duplex LTC2855, the leakage on the driver output pins is guaranteed to be less than $10\mu\text{A}$ over the entire common mode range of -7V to $+12\text{V}$. On the half-duplex LTC2854, the impedance is dominated by the receiver input resistance, R_{IN} .

Driver Overvoltage and Overcurrent Protection

The driver outputs are protected from short-circuits to any voltage within the Absolute Maximum range of ($V_{\text{CC}} - 15\text{V}$) to $+15\text{V}$. The typical peak current in this condition does not exceed 180mA .

If a high driver output is shorted to a voltage just above V_{CC} , a reverse current will flow into the supply. When this voltage exceeds V_{CC} by about 1.4V , the reverse current turns off. Preventing the driver from turning off with outputs shorted to output voltages just above V_{CC} keeps the driver active even for receiver loads that have a positive common mode with respect to the driver — a valid condition.

The worst-case peak reverse short-circuit current can be as high as 300mA in extreme cold conditions. If this current cannot be absorbed by the supply, a 3.6V Zener diode can be added in parallel with the supply to sink this current.

All devices also feature thermal shutdown protection that disables the driver and receiver in case of excessive power dissipation (see Note 4).

Receiver and Failsafe

With the receiver enabled, when the absolute value of the differential voltage between the A and B pins is greater than 200mV , the state of RO will reflect the polarity of (A-B).

The LTC2854/LTC2855 have a failsafe feature that guarantees the receiver output to be in a logic-high state when the inputs are either shorted, left open, or terminated (externally or internally), but not driven. This failsafe feature is guaranteed to work for inputs spanning the entire common mode range of -7V to $+12\text{V}$.

The receiver output is internally driven high (to V_{CC}) or low (to ground) with no external pull-up needed. When the receiver is disabled the RO pin becomes high-Z with leakage of less than $\pm 1\mu\text{A}$ for voltages within the supply range.

Receiver Input Resistance

The receiver input resistance from A or B to ground is guaranteed to be greater than $96\text{k}\Omega$ when the termination is disabled. This is 8X higher than the requirements for the RS485 standard and thus this receiver represents a one-eighth unit load. This, in turn, means that 8X the standard number of receivers, or 256 total, can be connected to a line without loading it beyond what is called out in the RS485 standard. The input resistance of the receivers is unaffected by enabling/disabling the receiver and by powering/unpowering the part. The equivalent input resistance looking into A and B is shown in Figure 9. The termination resistor cannot be enabled by TE if the device is unpowered or in thermal shutdown mode.

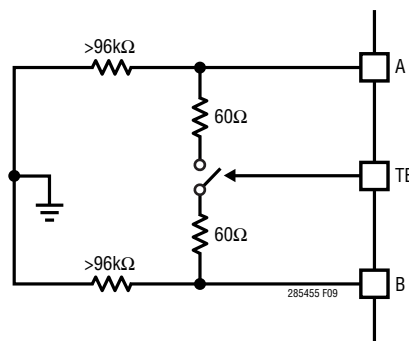

Figure 9. Equivalent Input Resistance into A and B (on the LTC2854, Valid if Driver is Disabled)

APPLICATIONS INFORMATION

Switchable Termination

Proper cable termination is very important for good signal fidelity. If the cable is not terminated with its characteristic impedance, reflections will result in distorted waveforms.

The LTC2854/LTC2855 are the first 3.3V RS485/RS422 transceivers to offer integrated switchable termination resistors on the receiver input pins. This provides the advantage of being able to easily change, through logic control, the line termination for optimal performance when configuring transceiver networks.

When the TE pin is high, the termination resistor is enabled and the differential resistance from A to B is 120Ω. Figure 10 shows the I/V characteristics between pins A and B with the termination resistor enabled and disabled. The resistance is maintained over the entire RS485 common mode range of -7V to +12V as shown in Figure 11.

The integrated termination resistor has a high frequency response which does not limit performance at the maximum specified data rate. Figure 12 shows the magnitude and phase of the termination impedance vs frequency.

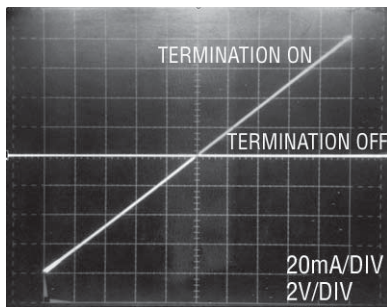
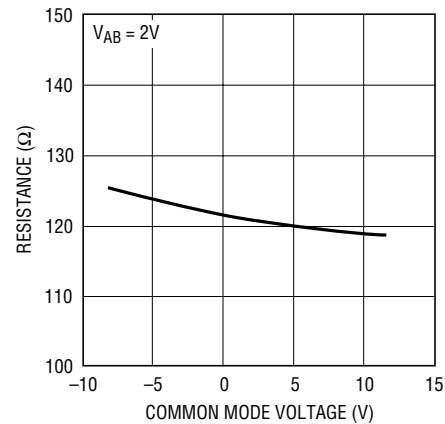
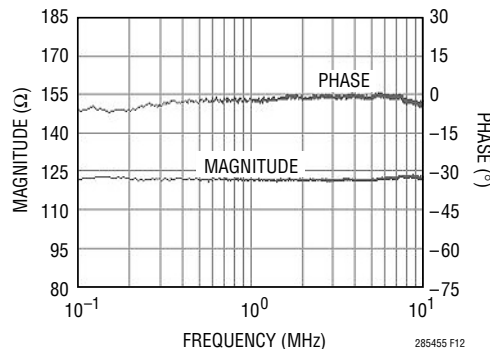

Figure 10. Curve Trace Between A and B with Termination Enabled and Disabled



285455 F11

Figure 11. Typical Resistance of the Enabled Terminator vs Voltage on B Pin



285455 F12

Figure 12. Termination Magnitude and Phase vs Frequency

APPLICATIONS INFORMATION

Supply Current

The unloaded static supply currents in the LTC2854/LTC2855 are very low — typically under 500 μ A for all modes of operation. In applications with resistively terminated cables, the supply current is dominated by the driver load. For example, when using two 120 Ω terminators with a differential driver output voltage of 2V, the DC current is 33mA, which is sourced by the positive voltage supply. This is true whether the terminators are external or internal such as in the LTC2854/LTC2855. Power supply current increases with toggling rate due to capacitive loading and this term can increase significantly at high data rates. Figure 13 shows supply current vs data rate for two different capacitive loads for the circuit configuration of Figure 4.

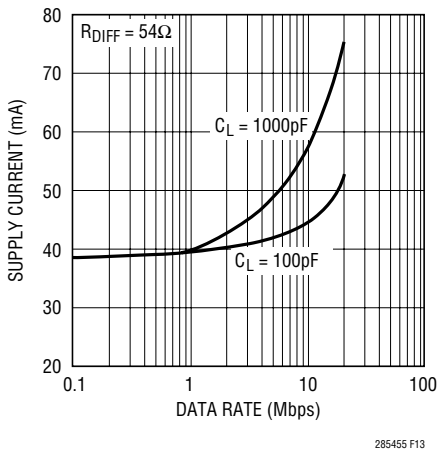

Figure 13. Supply Current vs Data Rate

High Speed Considerations

A ground plane layout is recommended for the LTC2854/LTC2855. A 0.1 μ F bypass capacitor less than one-quarter inch away from the V_{CC} pin is also recommended. The PC board traces connected to signals A/B and Z/Y (LTC2855) should be symmetrical and as short as possible to maintain good differential signal integrity. To minimize capacitive effects, the differential signals should be separated by more than the width of a trace and should not be routed on top of each other if they are on different signal planes.

Care should be taken to route outputs away from any sensitive inputs to reduce feedback effects that might cause noise, jitter, or even oscillations. For example, in

the full duplex LTC2855, DI and A/B should not be routed near the driver or receiver outputs.

The logic inputs of the LTC2854/LTC2855 have 150mV of hysteresis to provide noise immunity. Fast edges on the outputs can cause glitches in the ground and power supplies which are exacerbated by capacitive loading. If a logic input is held near its threshold (typically 1.5V), a noise glitch from a driver transition may exceed the hysteresis levels on the logic and data input pins causing an unintended state change. This can be avoided by maintaining normal logic levels on the pins and by slewing inputs through their thresholds by faster than 1V/ μ s when transitioning. Good supply decoupling and proper line termination also reduces glitches caused by driver transitions.

Cable Length vs Data Rate

For a given data rate, the maximum transmission distance is bounded by the cable properties. A typical curve of cable length vs data rate compliant with the RS485/RS422 standards is shown in Figure 14. Three regions of this curve reflect different performance limiting factors in data transmission. In the flat region of the curve, maximum distance is determined by resistive losses in the cable. The downward sloping region represents limits in distance and data rate due to AC losses in the cable. The solid vertical line represents the specified maximum data rate in the RS485/RS422 standards. The dashed lines at 20Mbps show the maximum data rates of the LTC2854/LTC2855.

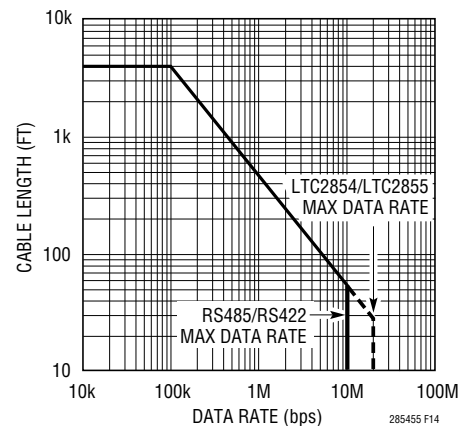
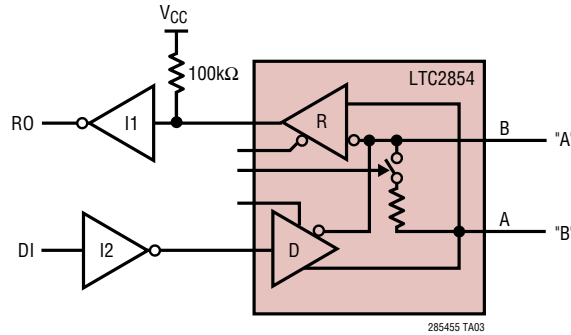

Figure 14. Cable Length vs Data Rate (RS485/RS422 Standards Shown in Vertical Solid Line)

TYPICAL APPLICATION

Failsafe "0" Application (Idle State = Logic "0")



PACKAGE DESCRIPTION

DD Package 10-Lead Plastic DFN (3mm × 3mm) (Reference LTC DWG # 05-08-1699)

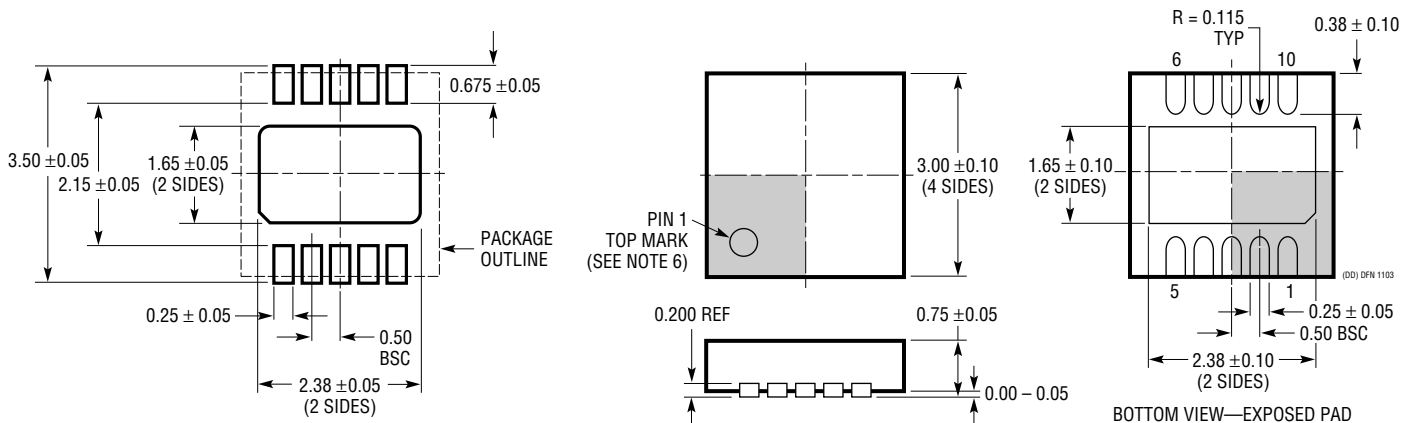

RECOMMENDED SOLDER PAD PITCH AND DIMENSIONS

NOTE:

1. DRAWING TO BE MADE A JEDEC PACKAGE OUTLINE M0-229 VARIATION OF (WEED-2). CHECK THE LTC WEBSITE DATA SHEET FOR CURRENT STATUS OF VARIATION ASSIGNMENT
2. DRAWING NOT TO SCALE
3. ALL DIMENSIONS ARE IN MILLIMETERS
4. DIMENSIONS OF EXPOSED PAD ON BOTTOM OF PACKAGE DO NOT INCLUDE MOLD FLASH. MOLD FLASH, IF PRESENT, SHALL NOT EXCEED 0.15mm ON ANY SIDE
5. EXPOSED PAD SHALL BE SOLDER PLATED
6. SHADED AREA IS ONLY A REFERENCE FOR PIN 1 LOCATION ON THE TOP AND BOTTOM OF PACKAGE

PACKAGE DESCRIPTION

DE/UE Package
12-Lead Plastic DFN (4mm × 3mm)
 (Reference LTC DWG # 05-08-1695)

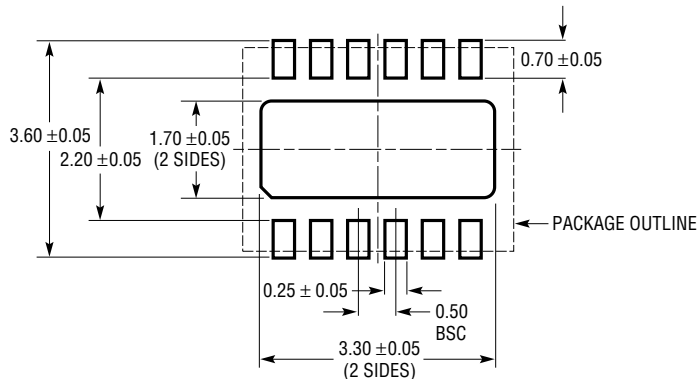

RECOMMENDED SOLDER PAD PITCH AND DIMENSIONS

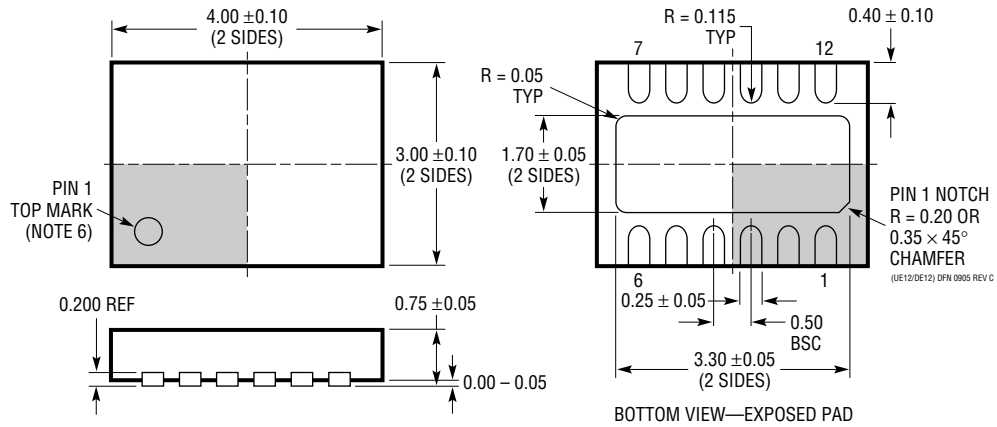

NOTE:

1. DRAWING PROPOSED TO BE A VARIATION OF VERSION (WGED) IN JEDEC PACKAGE OUTLINE M0-229
2. DRAWING NOT TO SCALE
3. ALL DIMENSIONS ARE IN MILLIMETERS
4. DIMENSIONS OF EXPOSED PAD ON BOTTOM OF PACKAGE DO NOT INCLUDE MOLD FLASH. MOLD FLASH, IF PRESENT, SHALL NOT EXCEED 0.15mm ON ANY SIDE
5. EXPOSED PAD SHALL BE SOLDER PLATED
6. SHADED AREA IS ONLY A REFERENCE FOR PIN 1 LOCATION ON THE TOP AND BOTTOM OF PACKAGE

PACKAGE DESCRIPTION

GN Package 16-Lead Plastic SSOP (Narrow .150 Inch) (Reference LTC DWG # 05-08-1641)

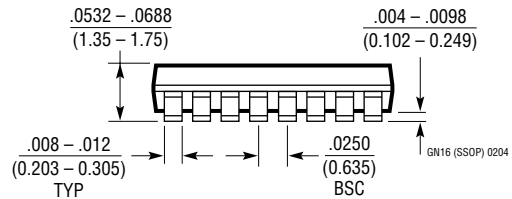
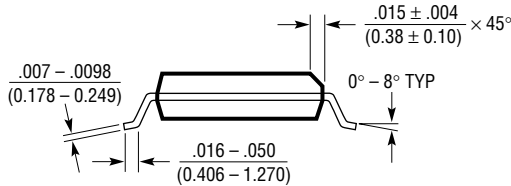
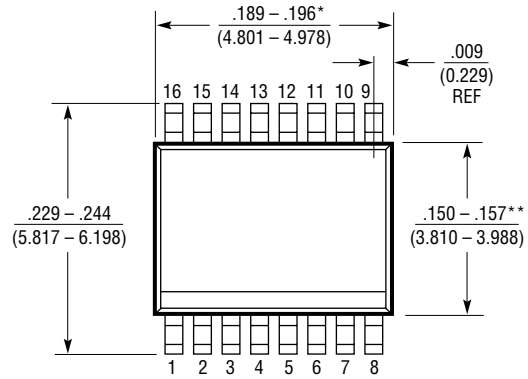
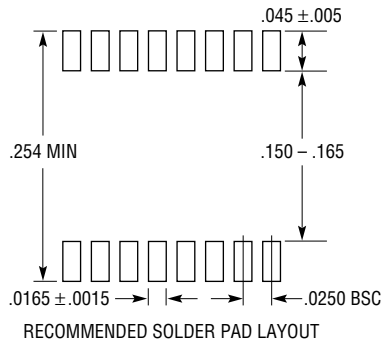

- NOTE:
1. CONTROLLING DIMENSION: INCHES
 2. DIMENSIONS ARE IN $\frac{\text{INCHES}}{\text{(MILLIMETERS)}}$
 3. DRAWING NOT TO SCALE

- *DIMENSION DOES NOT INCLUDE MOLD FLASH. MOLD FLASH SHALL NOT EXCEED 0.006* (0.152mm) PER SIDE
- **DIMENSION DOES NOT INCLUDE INTERLEAD FLASH. INTERLEAD FLASH SHALL NOT EXCEED 0.010* (0.254mm) PER SIDE

Information furnished by Linear Technology Corporation is believed to be accurate and reliable. However, no responsibility is assumed for its use. Linear Technology Corporation makes no representation that the interconnection of its circuits as described herein will not infringe on existing patent rights.

TYPICAL APPLICATION

Multi-Node Network with End Termination Using the LTC2854

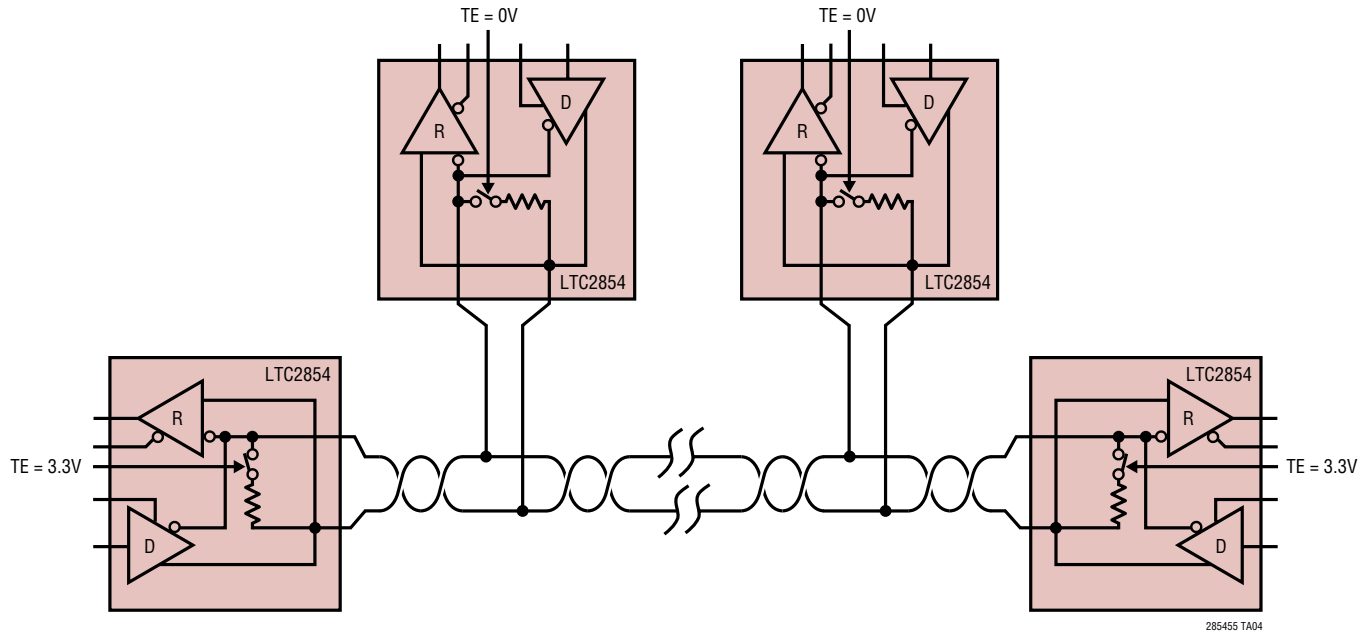

RELATED PARTS

PART NUMBER	DESCRIPTION	COMMENTS
LTC485	Low Power RS485 Interface Transceiver	$I_{CC} = 300\mu A$ (Typ)
LTC491	Differential Driver and Receiver Pair	$I_{CC} = 300\mu A$
LTC1480	3.3V Ultralow Power RS485 Transceiver	3.3V Operation
LTC1483	Ultralow Power RS485 Low EMI Transceiver	Controlled Driver Slew Rate
LTC1485	Differential Bus Transceiver	10Mbps Operation
LTC1487	Ultralow Power RS485 with Low EMI, Shutdown and High Input Impedance	Up to 256 Transceivers on the Bus
LTC1520	50Mbps Precision Quad Line Receiver	Channel-to-Channel Skew 400ps (Typ)
LTC1535	Isolated RS485 Full-Duplex Transceiver	2500V _{RMS} Isolation in Surface Mount Package
LTC1685	52Mbps RS485 Transceiver with Precision Delay	Propagation Delay Skew 500ps (Typ)
LT1785	60V Fault Protected RS485 Transceiver	60V Tolerant, 15kV ESD
LTC2856/LTC2857/ LTC2858	20Mbps and Slew Rate-Limited, 15kV RS485/RS422 Transceiver	Up to 256 Transceivers on the Bus
LTC2859/LTC2861	20Mbps RS485 Transceiver with Integrated Switchable Termination	5V Integrated, Switchable, 120Ω Termination Resistor, 15kV ESD