

Video Signal Driver for DVD Player Monolithic IC MM1623XFBE

Outline

This 6ch video driver IC was developed for use in DVD players/recorders.

The LPF that attenuates the DAC noise element has a built-in switching function to handle both progressive and interlace signals. In addition, the driver structure is 6db, 75Ω x 2 lines.

Also, the number of external ESD protection diodes has been reduced thanks to the S1/S2 DC superimpose function and reinforced output pin ESD protection element.

Features

1. 75W driver can drive 2 lines.
2. S/N=63dB typ.
3. Built-in 6dB amp.
4. Built-in filter switching function for progressive/interlace signal
5. Built-in high performance 4th LPF.
6. 0.75MHz/100kHz max. ±1.0dB 27MHz/100kHz typ. -40dB
7. +/- 15KV ESD for aerial discharge.
8. S1/S2 Built-in DC superimpose function.
9. Control pin allows component circuit to handle RGB signals.

Package

SOP-28

Pin Assignment

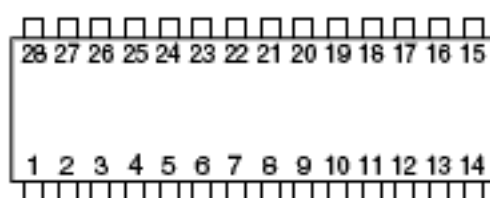

SOP-28
(TOP VIEW)

1	Vcc1	15	GND2
2	CIN	16	COUT
3	MUTE1	17	GND2
4	CVBSIN	18	COUT
5	YC MIX.	19	GND2
6	YIN	20	CYOUT
7	GND1	21	YOUT
8	BIAS	22	GND2
9	I/P	23	CVBSOUT
10	CYIN	24	S2
11	CLP	25	S1
12	CIN	26	COUT
13	MUTE2	27	S-DCOUT
14	CIN	28	Vcc2

Block Diagram

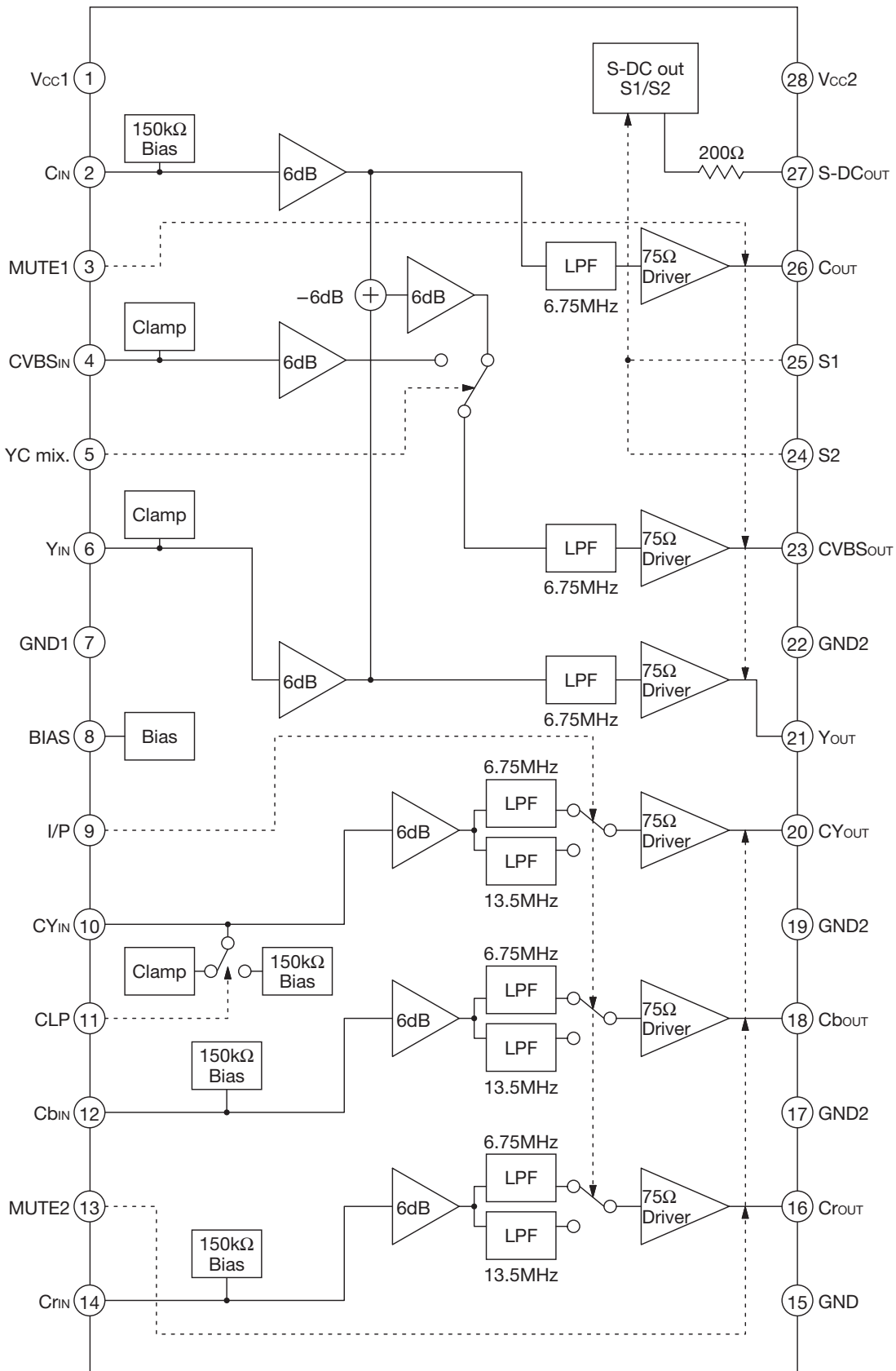

Pin Description

Pin no.	Pin name	Function	Internal equivalent circuit diagram
1 28	Vcc1 Vcc2	Vcc Vcc2 is power supply for 75Ω driver.	
2	CIN	Croma signal input	
3 13	MUTE1 MUTE2	Mute select Using of MUTE and POWER-SAVING.	
4 6	CVBSIN YIN	Video signal input (Composite video or Y) Sync tip clamp input	
5	YC mix.	YC MIX select	
7 15 17 19 22	GND1 GND2 GND2 GND2 GND2	GND GND2 is ground for 75Ω driver.	

Pin no.	Pin name	Function	Internal equivalent circuit diagram
8	BIAS	Bias	
9	I/P	Interlace / Progressive select	
10	CY _{IN}	Luminance input The input can select Sync tip clamp or Bias. Input signal : Y or G	
11	CLP	Input clamp select	
12 14	Cb _{IN} Cr _{IN}	Component input Input signal : Cb or B Cr or R	

Pin no.	Pin name	Function	Internal equivalent circuit diagram
16 18 20 21 23 26	C _{OUT} Cb _{OUT} CY _{OUT} Y _{OUT} CVBS _{OUT} C _{OUT}	Signal output	
24 25	S1 S2	S1/S2 select	
27	S-DC _{OUT}	S1/S2 DC output	

Absolute Maximum Ratings (Ta=25°C)

Item	Symbol	Ratings	Units
Storage temperature	T _{STG}	-65~+150	°C
Operating temperature	T _{OPR}	-40~+85	°C
Supply Voltage	V _{CC max.}	7	V
Allowable loss *	P _d	1.4	W

* Board mounting power dissipation. Board size 100 X100 X1.6mm

Recommended Operating Conditions

Item	Symbol	Ratings	Units
Operating temperature	T _{OPR}	-40~+85	°C
Operating voltage	V _{CCOP}	4.5~5.5	V

Electrical Characteristics (Except where noted otherwise, Ta=25°C, V_{CC}=5V)

Item	Symbol	Measurement conditions	Min.	Typ.	Max.	Units		
Supply current 1	I _{CC1}	No signal	77	110	143	mA		
Supply current 2	I _{CC2}	No signal, Mute1: ON	39	56	73	mA		
Supply current 3	I _{CC3}	No signal, Mute2: ON	39	56	73	mA		
Supply current 4	I _{CC4}	No signal, Mute1 and Mute2: ON	1	3	5	mA		
Croma input	V _{CIN}	2 PIN	1.9	2.4	2.9	V		
Composite video input	V _{CVBSIN}	4 PIN	0.9	1.1	1.3	V		
Luminance input	V _{YIN, CYIN}	6, 10 PIN	0.9	1.1	1.3	V		
Component input	V _{CBIN, CHIN}	12, 14 PIN	1.9	2.4	2.9	V		
Croma output	V _{COUT}	26 PIN		2.4		V		
Composite video output	V _{CVBSOUT}	23 PIN		1.1		V		
Luminance output	V _{YOUT, CYOUT}	21, 20 PIN		1.1		V		
Component output	V _{CBOUT, CHOUT}	18, 16 PIN		2.4		V		
Control terminal input current	H	I _{IHm} (*1)	3, 5, 9, 11, 13, 24, 25 PIN V _H =4.5V		350	μA		
	L	I _{ILm} (*1)	3, 5, 9, 11, 13, 24, 25 PIN V _L =0.4V		35	μA		
Control terminal input voltage	H	V _{thHm} (*1)	2.1			V		
	L	V _{thLm} (*1)			0.7	V		
S-DC out terminal output voltage	L	V _{DCCOUTL}	R _L =10kΩ+100kΩ		0.1	0.5	V	
	M	V _{DCCOUTM}	R _L =10kΩ+100kΩ		1.6	2.1	2.4	V
	H	V _{DCCOUTH}	R _L =10kΩ+100kΩ		4.3	4.6	V	
Input impedance	Z _{CIN, CBIN, CHIN}	2, 12, 14 PIN	100	150	200	kΩ		
Output impedance	Z _{S-DCOUT}	27 PIN		200		Ω		
Voltage gain	G _{1n} (*2)	SIN wave: 1V, f=100kHz	5.7	6.0	6.3	dB		

Item	Symbol	Measurement conditions	Min.	Typ.	Max.	Units
Frequency characteristic 1 (C, CVBS, Y)	f ₁₋₅ (*2)	100 (IRE) SIN wave+40 (IRE) SYNC 6.75MHz/100kHz	-1.5	-0.5	0.5	dB
	f ₂₋₅ (*2)	100 (IRE) SIN wave+40 (IRE) SYNC 27MHz/100kHz		-33	-27	dB
Frequency characteristic 2 (CY, Cb, Cr) at Interlace select	f ₃₋₈ (*2)	100 (IRE) SIN wave+40 (IRE) SYNC 6.75MHz/100kHz	-0.5	0.5	1.5	dB
	f ₄₋₈ (*2)	100 (IRE) SIN wave+40 (IRE) SYNC 27MHz/100kHz		-28	-22	dB
Frequency characteristic 3 (CY, Cb, Cr) at Progressive select	f ₅₋₈ (*2)	100 (IRE) SIN wave+40 (IRE) SYNC 13.5MHz/100kHz	-1.5	-0.5	0.5	dB
	f ₆₋₈ (*2)	100 (IRE) SIN wave+40 (IRE) SYNC 54MHz/100kHz		-28	-22	dB
Differential gain	DG ₁₋₃ (*2)	Staircase signal 1V		1.0	1.5	%
Differential phase	DP ₁₋₃ (*2)	Staircase signal 1V		1.0	1.5	°
Output dynamic range	DR _{1,4,7,8} (*2)	SIN wave; 100kHz, THD=1.0%	2.6	3.0		V
	DR _{2,3,5,6} (*2)	SIN wave; 100kHz, THD=1.0%	2.6	2.8		V
Crosstalk	CT _n (*2)	f=4.43MHz, 1V		-60	-55	dB
S/N1	SN ₁₄₋₈ (*2)	BW: 100k~6MHz		-83		dB
S/N2	SN ₂₁₋₃ (*2)	BW: 100k~6MHz at mix. OUT		-77		dB
Group delay 1	t _{1GD1-5} (*2)	at 100kHz		40	80	ns
Group delay 2	t _{2GD6-8} (*2)	Interlace select at 100kHz		35	80	ns
Group delay 3	t _{3GD6-8} (*2)	Progressive select at 100kHz		22	50	ns
Group delay deviation 1 (C, CVBS Y)	Δt _{1GD1-5} (*2)	to 3.58MHz		4	10	ns
		to 4.42MHz		6	10	ns
		to 6MHz		12	20	ns
Group delay deviation 2 (CY, Cb Cr) at Interlace select	Δt _{2GD6-8} (*2)	to 1MHz		1	10	ns
		to 4MHz		4	10	ns
		to 6MHz		10	20	ns
Group delay deviation 3 (CY, Cb Cr) at Progressive select	Δt _{3GD6-8} (*2)	to 2MHz		1	10	ns
		to 8MHz		4	10	ns
		to 12MHz		10	20	ns
Between channel Group delay deviation 1	Δt _{1chGD}	Between C and Y at 3.58MHz		1	10	ns
Between channel Group delay deviation 2	Δt _{2chGD}	Between CY and Cb (Cr) at 1MHz (Interlace)		1	10	ns
Between channel Group delay deviation 3	Δt _{3chGD}	Between CY and Cb (Cr) at 2MHz (Progressive)		1	10	ns

Note: *1 The subscript number "m" is the terminal of right table.

m	Terminal
1	MUTE1
2	MUTE2
3	YC mix.
4	I/P
5	CLP
6	S1
7	S2

Note: *2 The subscript number "n" is the combination of right table.

n	Input	Output
1	C _{IN}	CVBS _{OUT}
2	CVBS _{IN}	
3	Y _{IN}	
4	C _{IN}	C _{OUT}
5	Y _{IN}	Y _{OUT}
6	CY _{IN}	CY _{OUT}
7	Cb _{IN}	Cb _{OUT}
8	Cr _{IN}	Cr _{OUT}

Measuring Circuit

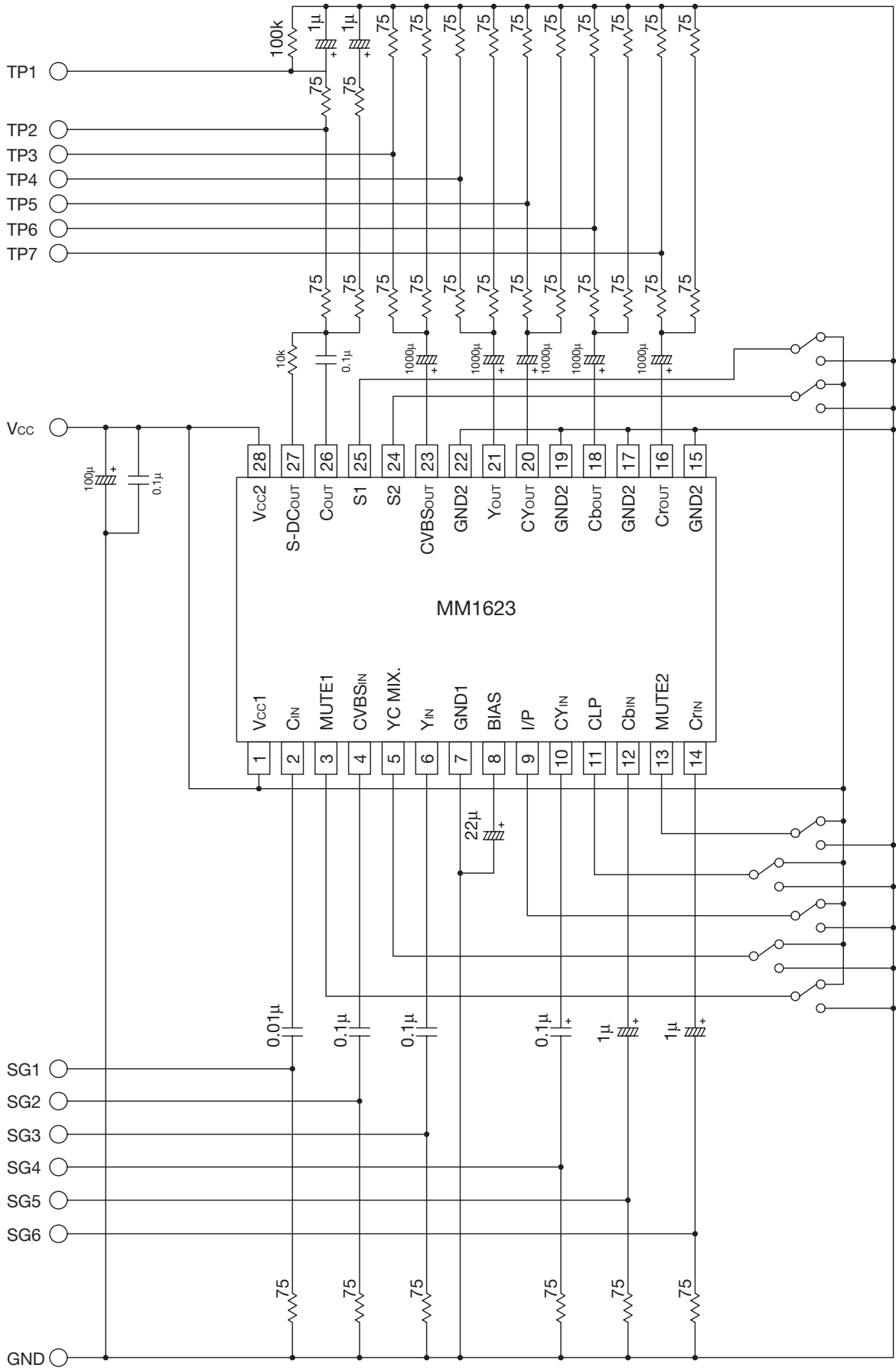

Switch Control Table

Input select	Output terminal	Control terminal			
		MUTE1	YC MIX.	MUTE2	CLP
MUTE	C _{OUT}	Low	*	*	*
C _{IN}		High	*	*	*
MUTE	CVBS _{OUT}	Low	*	*	*
Y _{IN} +C _{IN}		High	Low	*	*
CVBS _{IN}			High	*	*
MUTE	Y _{OUT}	Low	*	*	*
Y _{IN}		High	*	*	*
MUTE	CY _{OUT}	*	*	Low	*
CY _{IN} (CLAMP)		*	*	High	Low
CY _{IN} (Bias)		*	*		High
MUTE	Cb _{OUT}	*	*	Low	*
Cb _{IN}		*	*	High	*
MUTE	Cr _{OUT}	*	*	Low	*
Cr _{IN}		*	*	High	*

*: Don't care

Control terminal	Status	CY, Cb, Cr LPF Bandwidth
I/P	Low	13.5MHz (Progressive)
	High	6.75MHz (Interlace)

Control terminal		S-DC _{OUT}	Signal Mode
S1	S2	Output Voltage	
Low	Low	0V	4:3 Normal
Low	High	2.1V	4:3 Letter box
High	High		
High	Low	4.6V	16:9 Squeeze

*: R_L=10kΩ+100kΩ

Application Circuit 2

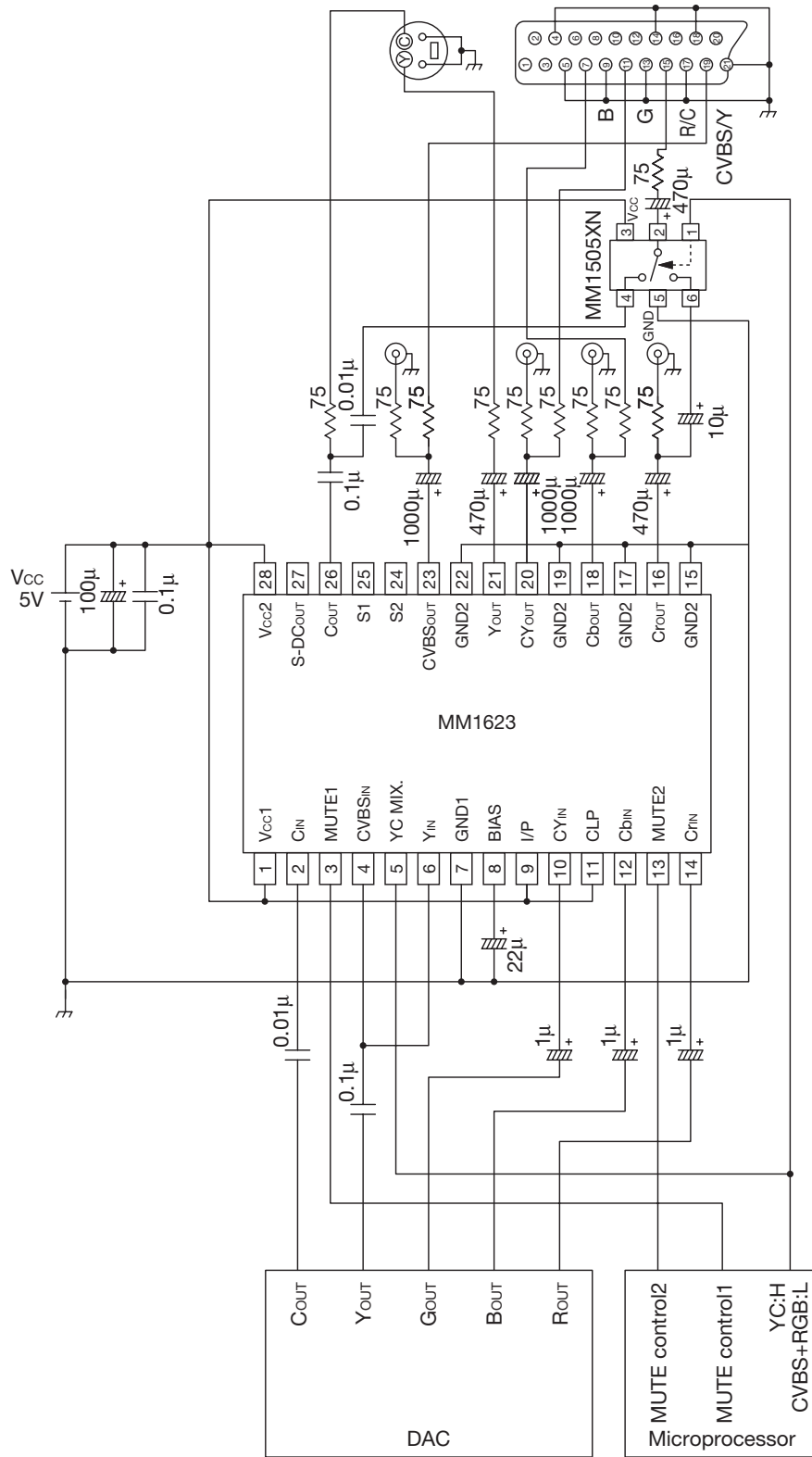

Note 1 Please arrange power supply bypass capacitor near the Vcc2 terminal (28pin).

Note 2 Please arrange the stray capacity component added to a signal output terminal to 20pF or less.

Characteristics

Frequency characteristic (COUT, CVBSout, Yout)

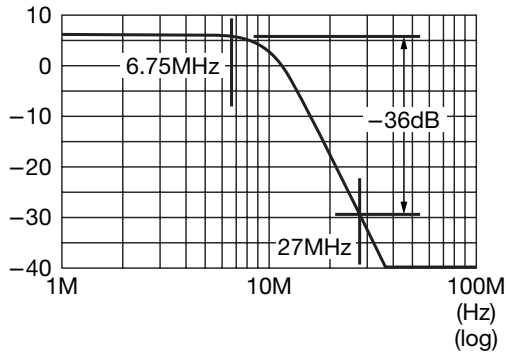

Group delay (COUT, CVBSout, Yout)

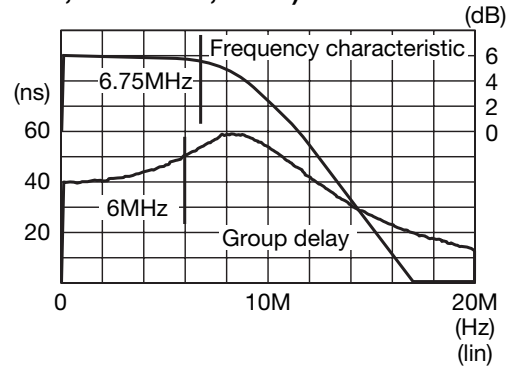

Frequency characteristic (CYout, Cbout, CrouT) (at Interlace)

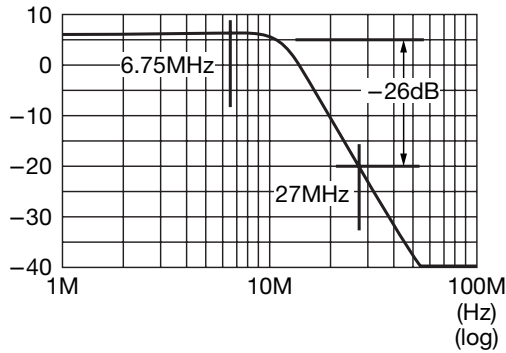

Group delay (CYout, Cbout, CrouT) (at Interlace)

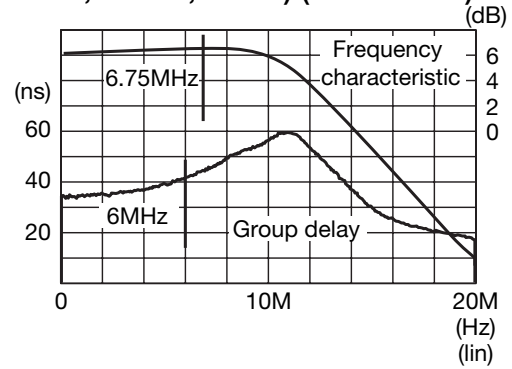

Frequency characteristic (CYout, Cbout, CrouT) (at Progressive)

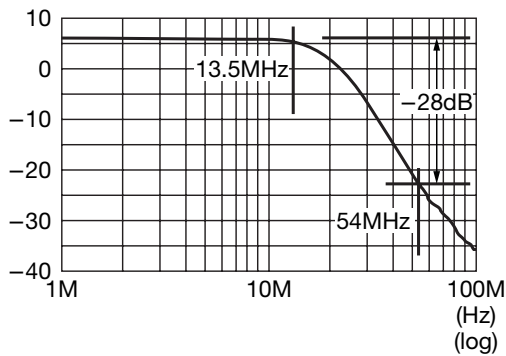

Group delay (CYout, Cbout, CrouT) (at Progressive)

