

**MSM52V1016LP****65,536-Word × 16-Bit CMOS STATIC RAM****DESCRIPTION**

The MSM52V1016LP is a 65,536-word by 16-bit CMOS static RAM featuring 3.0 V to 3.6 V power supply operation in the range of  $-40^{\circ}\text{C}$  to  $85^{\circ}\text{C}$  and direct LVCMOS input/output compatibility. Since the circuitry is completely static, external clock and refreshing operations are unnecessary, making this device very easy to use. The MSM52V1016LP can be used in the high-speed operation of an access time 100 ns due to adopting a high-performance CMOS technology and in the low current consumption of a standby current max.  $50\ \mu\text{A}$  when there is no chip selection. In addition, the MSM52V1016LP is provided with a chip enable signal (CE) suited to the expansion of a memory capacity, an output enable signal ( $\overline{\text{OE}}$ ) suited to the I/O bus line control, and a byte select signal ( $\overline{\text{LB}}$ ,  $\overline{\text{UB}}$ ) that can independently control the input/output of a lower byte and an upper byte.

**FEATURES**

- 65,536-word × 16-bit configuration
- Power supply voltage: 3.0 V to 3.6 V
- Fully static operation
- Operating temperature range:  $T_a = -40^{\circ}\text{C}$  to  $85^{\circ}\text{C}$
- (Input/Output) LVCMOS compatible
- 3-state output
- Data retention available at power supply voltage 2 V
- Package options:
 

40-pin 525 mil plastic SOP	(SOP40-P-525-1.27-K)	(Product: MSM52V1016LP-xxGS-K)
44-pin 400 mil plastic TSOP (Type II)	(TSOPII44-P-400-0.80-K)	(Product: MSM52V1016LP-xxTS-K)
	(TSOPII44-P-400-0.80-L)	(Product: MSM52V1016LP-xxTS-L)

 xx indicates speed rank.

**PRODUCT FAMILY**

Family	Access Time (Max.)	Power Dissipation	
		Operating (Max.)	Standby (Max.)
MSM52V1016LP-10	100 ns	180 mW	0.18 mW
MSM52V1016LP-12	120 ns	144 mW	

**PIN CONFIGURATION (TOP VIEW)**

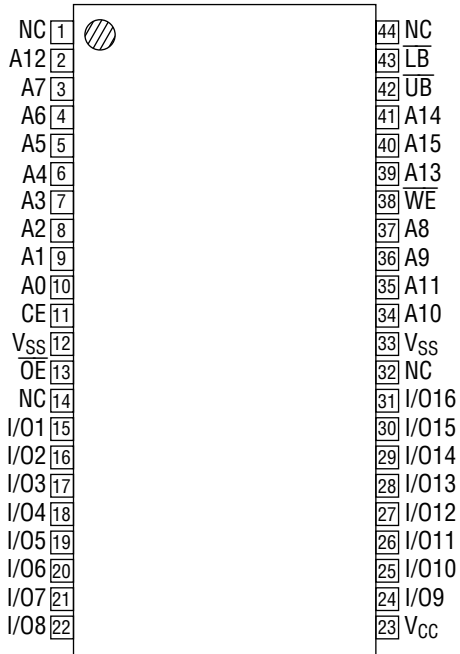

44-Pin Plastic TSOP (II)  
(K Type)

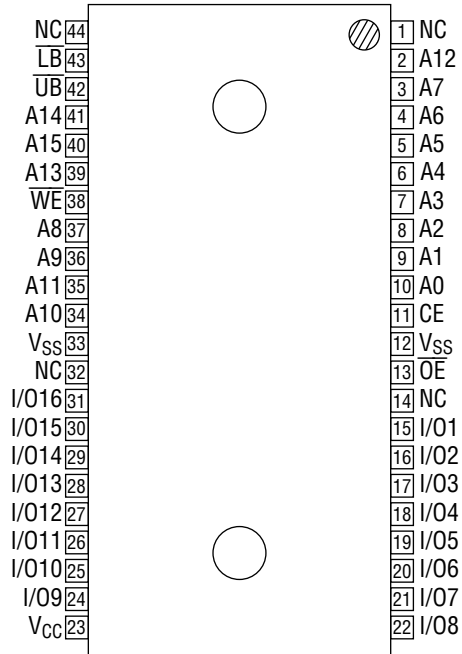

44-Pin Plastic TSOP (II)  
(L Type)

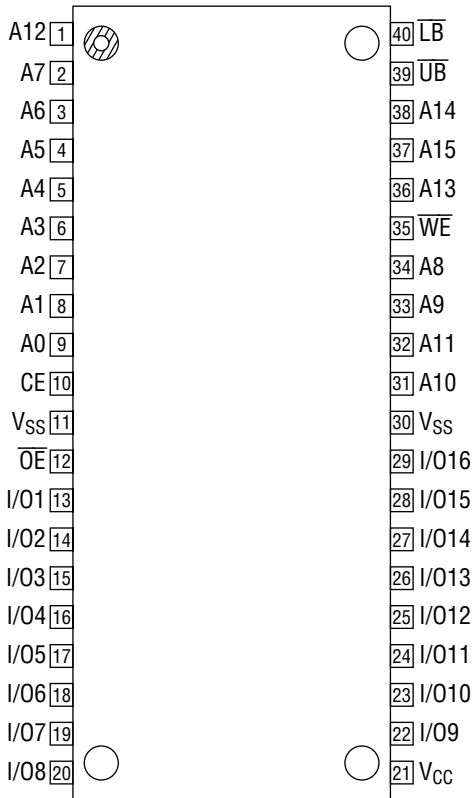

40-Pin Plastic SOP

Pin Name	Function
A0 - A15	Address Input
I/O1 - I/O16	Data Input/Output
CE	Chip Enable
WE	Write Enable
OE	Output Enable
LB, UB	Byte Data Select
Vcc, Vss	Power Supply
NC	No Connection

**BLOCK DIAGRAM**

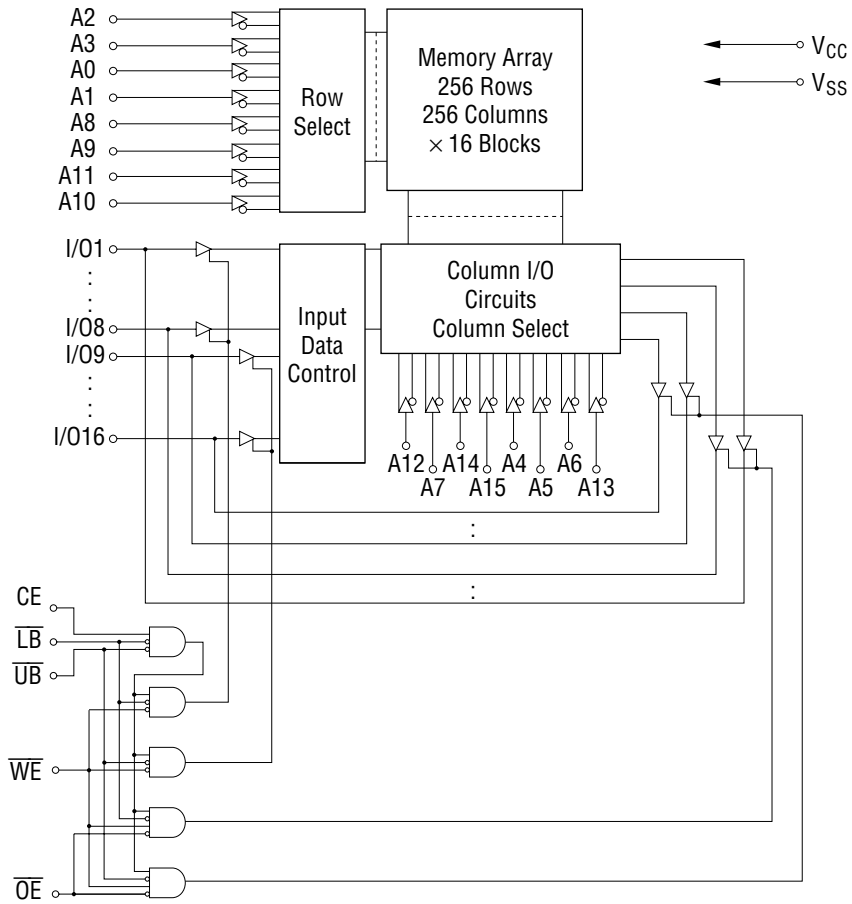

**FUNCTION TABLE**

Operating Mode	CE	LB	UB	WE	OE	I/O1 - I/O8	I/O9 - I/O16	Power Mode
Non Selectable	L	X	X	X	X	High-Z	High-Z	Standby
	X	H	H	X	X	High-Z	High-Z	Standby
Read Cycle	H	L	L	H	L	Data Read	Data Read	Active
	H	L	H	H	L	Data Read	High-Z	Active
	H	H	L	H	L	High-Z	Data Read	Active
	H	L	L	H	H	High-Z	High-Z	Active
	H	L	H	H	H	High-Z	High-Z	Active
	H	H	L	H	H	High-Z	High-Z	Active
Write Cycle	H	L	L	L	X	Data Write	Data Write	Active
	H	L	H	L	X	Data Write	High-Z	Active
	H	H	L	L	X	High-Z	Data Write	Active

X: Don't Care ("H" or "L")

## ELECTRICAL CHARACTERISTICS

### Absolute Maximum Ratings

Parameter	Symbol	Condition	Rating	Unit
Power Supply Voltage	$V_{CC}$	$T_a = 25^\circ\text{C}$ , for $V_{SS}$	-0.5 to 4.6	V
Pin Voltage	$V_T$		$-0.5^*$ to $V_{CC} + 0.5$	V
Power Dissipation	$P_D$	$T_a = 25^\circ\text{C}$	0.7	W
Operating Temperature	$T_{opr}$	—	-40 to 85	$^\circ\text{C}$
Storage Temperature	$T_{stg}$	—	-55 to 125	$^\circ\text{C}$

\* -1.2 V Min. for pulse width less than 30 ns.

### Recommended Operating Conditions

Parameter	Symbol	Condition	Min.	Typ.	Max.	Unit
Power Supply Voltage	$V_{CC}$	—	3.0	—	3.6	V
	$V_{SS}$		0	0	0	V
Data Retention Voltage	$V_{CCH}$	—	2	—	3.6	V
Input High Voltage	$V_{IH}$	$V_{CC} = 3.0\text{ V to }3.6\text{ V}$	2.4	—	$V_{CC} + 0.3$	V
Input Low Voltage	$V_{IL}$		$-0.3^*$	—	0.4	V
Load Capacitance	$C_L$	—	—	—	100	pF
Fan Out	N	LVC MOS	—	—	1	—

\* -1.2 V Min. for pulse width less than 30 ns.

### Capacitance

( $T_a = 25^\circ\text{C}$ ,  $f = 1\text{ MHz}$ )

Parameter	Symbol	Condition	Min.	Max.	Unit
Input Capacitance	$C_I$	$V_I = 0\text{ V}$	—	10	pF
Input/Output Capacitance	$C_{I/O}$	$V_{I/O} = 0\text{ V}$	—	10	pF

Note: This parameter is periodically sampled and not 100% tested.

**DC Characteristics**

( $V_{CC} = 3.0\text{ V to }3.6\text{ V}$ ,  $T_a = -40^\circ\text{C to }85^\circ\text{C}$ )

Parameter	Symbol	Condition	MSM52V1016LP			Unit
			Min.	Typ.	Max.	
Input Leakage Current	$I_{LI}$	$V_{IN} = 0\text{ to }V_{CC}$	-1.0	—	1.0	$\mu\text{A}$
Output Leakage Current	$I_{LO}$	$CE = V_{IL}\text{ or } \overline{LB}, \overline{UB} = V_{IH}$ or $\overline{OE} = V_{IH}\text{ or } \overline{WE} = V_{IL}$ , $V_{OUT} = 0\text{ to }V_{CC}$	-1.0	—	1.0	$\mu\text{A}$
Output High Voltage	$V_{OH}$	$I_{OH} = -100\ \mu\text{A}$	$V_{CC} - 0.2$	—	—	V
Output Low Voltage	$V_{OL}$	$I_{OL} = 100\ \mu\text{A}$	—	—	0.2	V
Standby Power Supply Current	$I_{CCS}$	$\overline{LB}, \overline{UB} \geq V_{CC} - 0.2\text{ V}$ , $CE \geq V_{CC} - 0.2\text{ V}$ or $0\text{ V} \leq CE \leq 0.2\text{ V}$ , $V_{IN} = 0\text{ to }V_{CC}$	—	—	50	$\mu\text{A}$
	$I_{CCS1}$	$\overline{LB}, \overline{UB} = V_{IH}\text{ or } CE = V_{IL}$	—	—	0.6	mA
Operating Power Supply Current	$I_{CCA}$	$\overline{LB}, \overline{UB} = V_{IL}$ , $CE = V_{IH}$ , $V_{IN} = V_{IH} / V_{IL}$ , $T_{CYC} = \text{Min. cycle}$ , $I_{OUT} = 0\text{ mA}$	—	—	①	mA
		$\overline{LB}, \overline{UB} \leq 0.2\text{ V}$ , $CE \geq V_{CC} - 0.2\text{ V}$ , $V_{IH} \geq V_{CC} - 0.2\text{ V}$ , $V_{IL} \leq 0.2\text{ V}$ , $T_{CYC} = 1\ \mu\text{s}$ , $I_{OUT} = 0\text{ mA}$	—	—	15	mA

① 52V1016LP-10 50 mA  
52V1016LP-12 40 mA

**AC Characteristics**

**Test Conditions**

Parameter	Condition
Input Pulse Level	$V_{IH} = 2.4\text{ V}$ , $V_{IL} = 0.4\text{ V}$
Input Rise and Fall Times	5 ns
Input/Output Timing Level	1.4 V
Output Load	$C_L = 100\text{ pF}$ , 1 LVCMOS

Read Cycle

(V<sub>CC</sub> = 3.0 V to 3.6 V, T<sub>a</sub> = -40°C to 85°C)

Parameter	Symbol	MSM52V1016LP-10		MSM52V1016LP-12		Unit
		Min.	Max.	Min.	Max.	
Read Cycle Time	t <sub>RC</sub>	100	—	120	—	ns
Address Access Time	t <sub>AA</sub>	—	100	—	120	ns
$\overline{\text{LB}}$ , $\overline{\text{UB}}$ Access Time	t <sub>LB</sub>	—	100	—	120	ns
	t <sub>UB</sub>	—	100	—	120	
CE Access Time	t <sub>CO</sub>	—	100	—	120	ns
$\overline{\text{OE}}$ Access Time	t <sub>OE</sub>	—	50	—	60	ns
$\overline{\text{LB}}$ , $\overline{\text{UB}}$ to Output in Low-Z	t <sub>LBLZ</sub>	10	—	10	—	ns
	t <sub>UBLZ</sub>	10	—	10	—	
CE to Output in Low-Z	t <sub>CLZ</sub>	10	—	10	—	ns
$\overline{\text{OE}}$ to Output in Low-Z	t <sub>OLZ</sub>	5	—	5	—	ns
$\overline{\text{LB}}$ , $\overline{\text{UB}}$ to Output in High-Z	t <sub>LBHZ</sub>	—	35	—	35	ns
	t <sub>UBHZ</sub>	—	35	—	35	
CE to Output in High-Z	t <sub>CHZ</sub>	—	35	—	35	ns
$\overline{\text{OE}}$ to Output in High-Z	t <sub>OHZ</sub>	—	35	—	35	ns
Output Hold Time from Address Change	t <sub>OH</sub>	10	—	10	—	ns

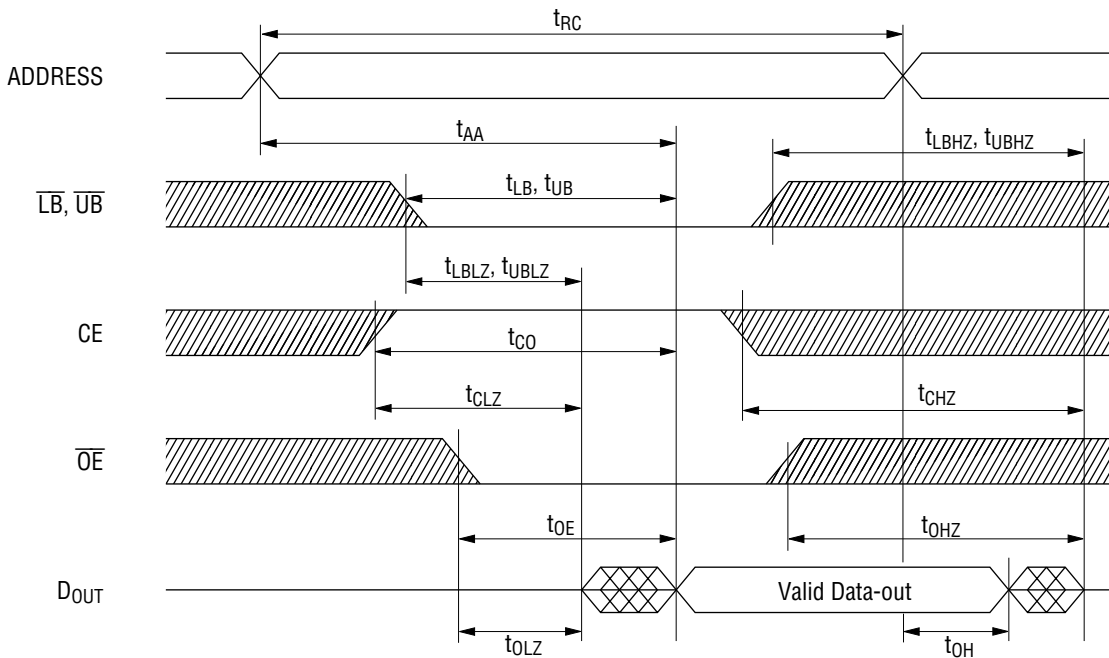

- Notes:
1. A read cycle occurs during the overlap of  $\overline{\text{LB}} = \text{"L"}$  (or  $\overline{\text{UB}} = \text{"L"}$ ), CE = "H",  $\overline{\text{OE}} = \text{"L"}$  and  $\overline{\text{WE}} = \text{"H"}$ .
  2. t<sub>LBHZ</sub>, t<sub>UBHZ</sub>, t<sub>CHZ</sub> and t<sub>OHZ</sub> are specified by the time when DATA is floating, not defined by the output level.

Write Cycle

( $V_{CC} = 3.0\text{ V to }3.6\text{ V}$ ,  $T_a = -40^\circ\text{C to }85^\circ\text{C}$ )

Parameter	Symbol	MSM52V1016LP-10		MSM52V1016LP-12		Unit
		Min.	Max.	Min.	Max.	
Write Cycle Time	$t_{WC}$	100	—	120	—	ns
Address Setup Time	$t_{AS}$	0	—	0	—	ns
Write Pulse Width	$t_{WP}$	75	—	90	—	ns
Write Recovery Time	$t_{WR}$	5	—	5	—	ns
Data Setup Time	$t_{DS}$	40	—	50	—	ns
Data Hold Time	$t_{DH}$	0	—	0	—	ns
$\overline{LB}$ , $\overline{UB}$ to End of Write	$t_{LBW}$	90	—	100	—	ns
	$t_{UBW}$	90	—	100	—	
CE to End of Write	$t_{CW}$	90	—	100	—	ns
Address Valid to End of Write	$t_{AW}$	90	—	100	—	ns
$\overline{WE}$ to Output in High-Z	$t_{WHZ}$	—	35	—	35	ns
Output Active from End of Write	$t_{WLZ}$	5	—	5	—	ns

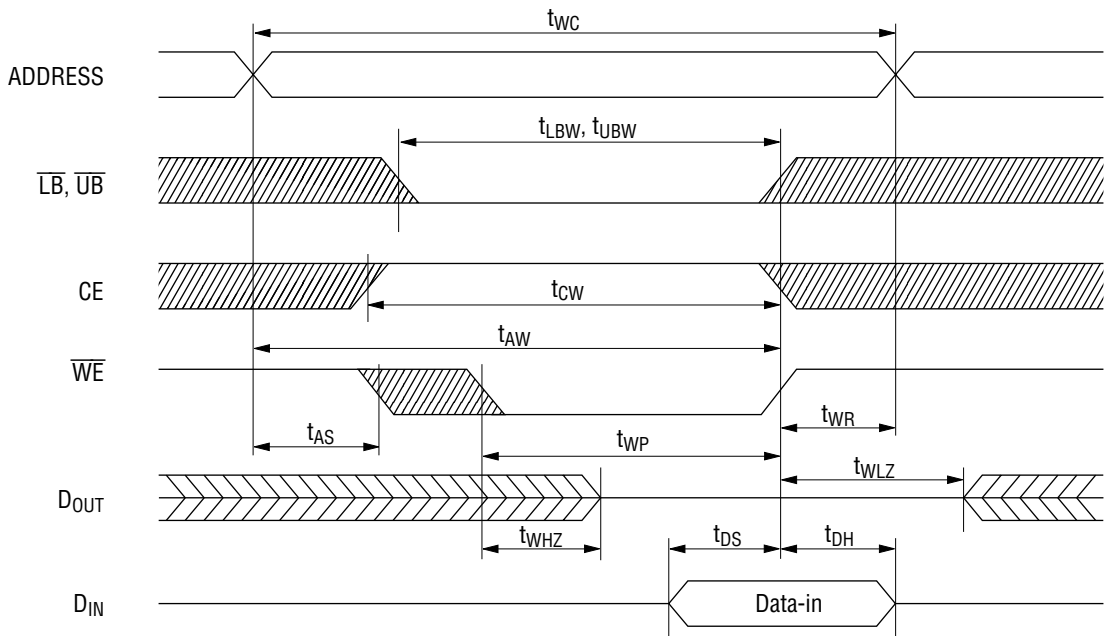

- Notes:
1. A write cycle occurs during the overlap of  $\overline{LB} = "L"$  (or  $\overline{UB} = "L"$ ),  $CE = "H"$  and  $\overline{WE} = "L"$ .
  2.  $\overline{OE}$  may be either of "H" or "L" in the write cycle.
  3.  $t_{AS}$  is specified from  $\overline{LB} = "L"$  (or  $\overline{UB} = "L"$ ),  $CE = "H"$  or  $\overline{WE} = "L"$ , whichever occurs last.
  4.  $t_{WP}$  is an overlap time of  $\overline{LB} = "L"$  (or  $\overline{UB} = "L"$ ),  $CE = "H"$  and  $\overline{WE} = "L"$ .
  5.  $t_{WR}$ ,  $t_{DS}$  and  $t_{DH}$  are specified from  $\overline{LB} = "H"$  (or  $\overline{UB} = "H"$ ),  $CE = "L"$  or  $\overline{WE} = "H"$ , whichever occurs first.
  6.  $t_{WHZ}$  is specified by the time when DATA output is floating, not defined by the output level.
  7. When I/O pins are in the output mode, don't apply the inverted input signal to the output pins.

Data Retention Characteristics

(Ta = -40°C to 85°C)

Parameter	Symbol	Condition	Min.	Typ.	Max.	Unit
Data Retention Power Supply Voltage	V <sub>CCH</sub>	$\overline{LB}, \overline{UB} \geq V_{CC} - 0.2 V,$ $CE \geq V_{CC} - 0.2 V$ or $0 V \leq CE \leq 0.2 V,$ $V_{IN} = 0 \text{ to } V_{CC}$	2.0	—	—	V
Data Retention Power Supply Current	I <sub>CCH</sub>	$V_{CC} = 3 V,$ $\overline{LB}, \overline{UB} \geq V_{CC} - 0.2 V,$ $CE \geq V_{CC} - 0.2 V$ or $0 V \leq CE \leq 0.2 V,$ $V_{IN} = 0 \text{ to } V_{CC}$	—	—	40*	μA
Chip Deselect to Data Retention Time	t <sub>CDR</sub>	—	0	—	—	ns
Operation Recovery Time	t <sub>R</sub>	—	50	—	—	ms

\* 5 μA Max. when Ta = 0°C to 40°C.

**$\overline{LB}, \overline{UB}$  Control**

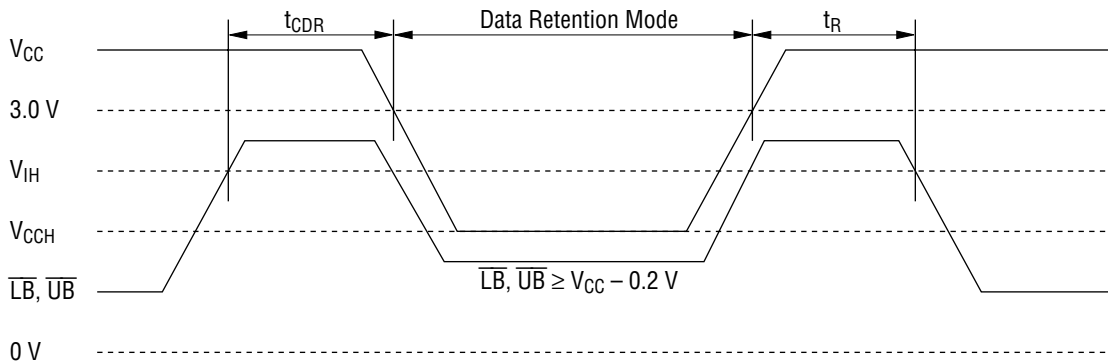

**CE Control**

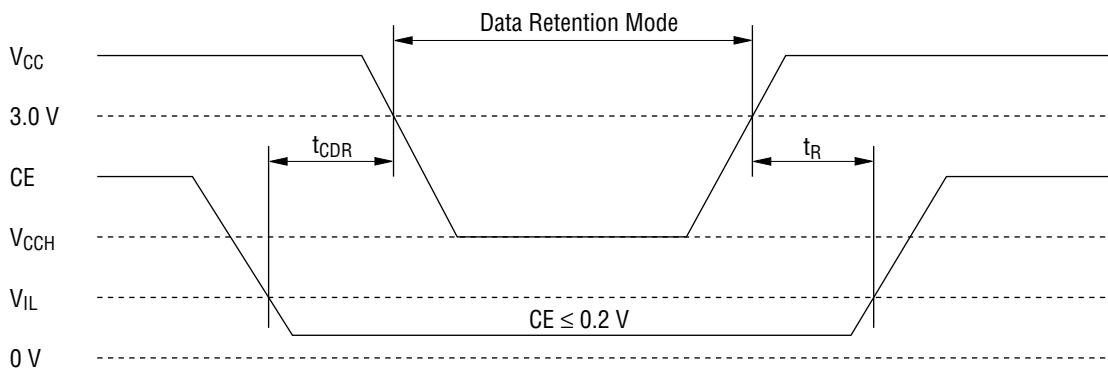



**PACKAGE DIMENSIONS**

(Unit : mm)

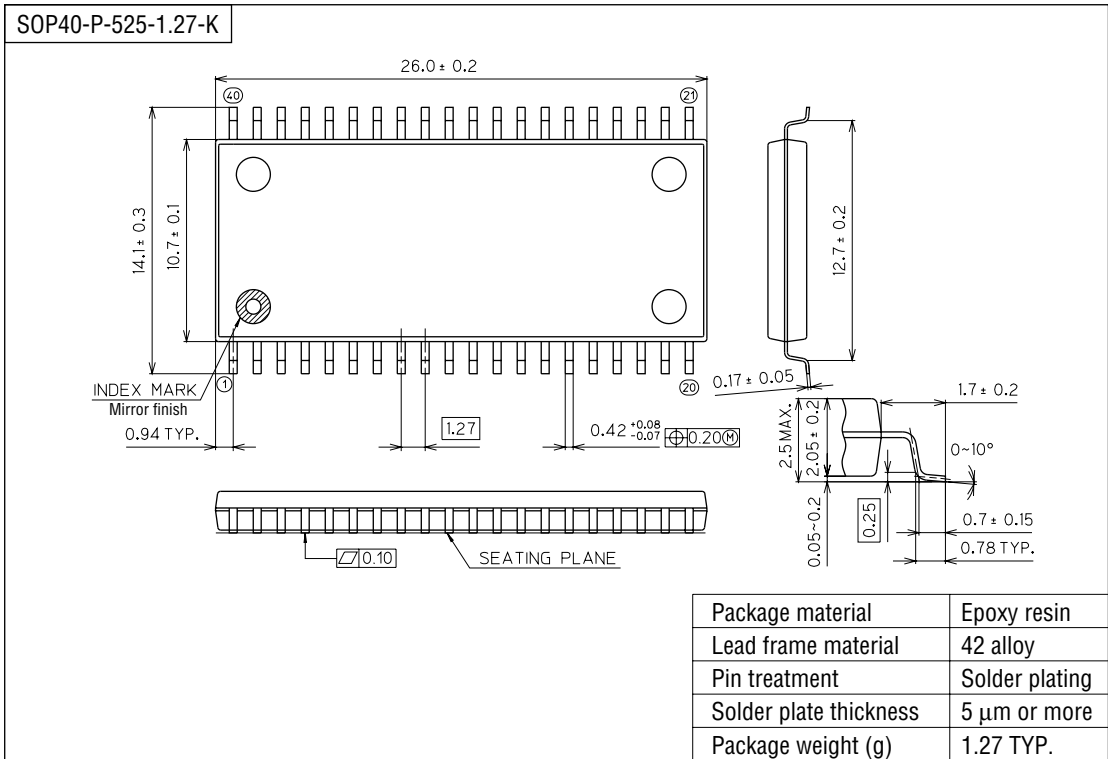

Notes for Mounting the Surface Mount Type Package

The SOP, QFP, TSOP, SOJ, QFJ (PLCC), SHP and BGA are surface mount type packages, which are very susceptible to heat in reflow mounting and humidity absorbed in storage. Therefore, before you perform reflow mounting, contact Oki's responsible sales person for the product name, package name, pin number, package code and desired mounting conditions (reflow method, temperature and times).

(Unit : mm)

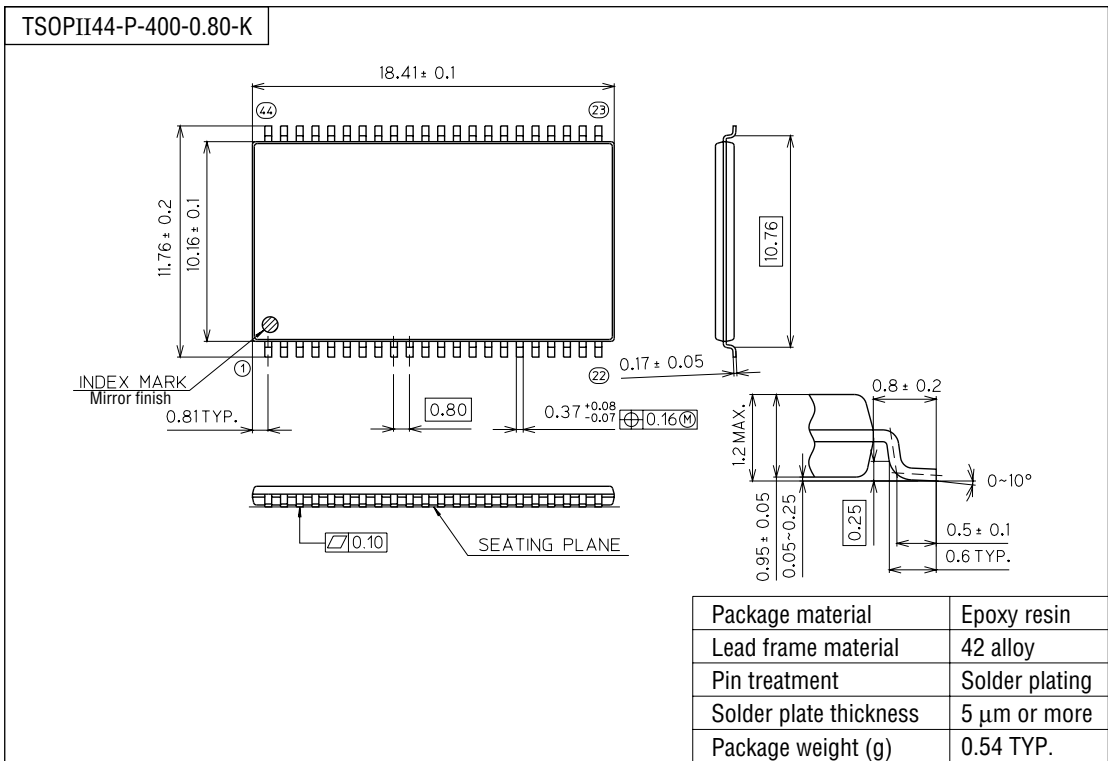

Notes for Mounting the Surface Mount Type Package

The SOP, QFP, TSOP, SOJ, QFJ (PLCC), SHP and BGA are surface mount type packages, which are very susceptible to heat in reflow mounting and humidity absorbed in storage. Therefore, before you perform reflow mounting, contact Oki's responsible sales person for the product name, package name, pin number, package code and desired mounting conditions (reflow method, temperature and times).