

TC74ACT151P, TC74ACT151F, TC74ACT151FN

8 - CHANNEL MULTIPLEXER

The TC74ACT151 is an advanced high speed CMOS 8 - CHANNEL MULTIPLEXER fabricated with silicon gate and double - layer metal wiring C²MOS technology.

It achieves the high speed operation similar to equivalent Bipolar Schottky TTL while maintaining the CMOS low power dissipation.

This device may be used as a level converter for interfacing TTL or NMOS to High Speed CMOS. The inputs are compatible with TTL, NMOS and CMOS output voltage levels.

One of eight data input signals (D0 - D7) is selected by decoding of the three - bit address input (A, B, C). The selected data appears on two outputs: non - inverting (Y) and inverting (W).

The STROBE input provides two output conditions; a low level on the STROBE input transfers the selected data to the outputs. A high level on the STROBE input sets the Y output low and the the W output high without regard to the data or select input conditions.

All inputs are equipped with protection circuits against static discharge or transient excess voltage.

FEATURES:

- High Speed..... $t_{pd} = 7.1ns(typ.)$ at $V_{CC} = 5V$
- Low Power Dissipation..... $I_{CC} = 8\mu A(Max.)$ at $T_a = 25^\circ C$
- Compatible with TTL outputs ... $V_{IL} = 0.8V (Max.)$
 $V_{IH} = 2.0V (Min.)$
- Symmetrical Output Impedance... $|I_{OH}| = I_{OL} = 24mA (Min.)$
Capability of driving 50Ω transmission lines.
- Balanced Propagation Delays..... $t_{pLH} \approx t_{pHL}$
- Pin and Function Compatible with 74F151

(Note) The JEDEC SOP (FN) is not available in Japan.

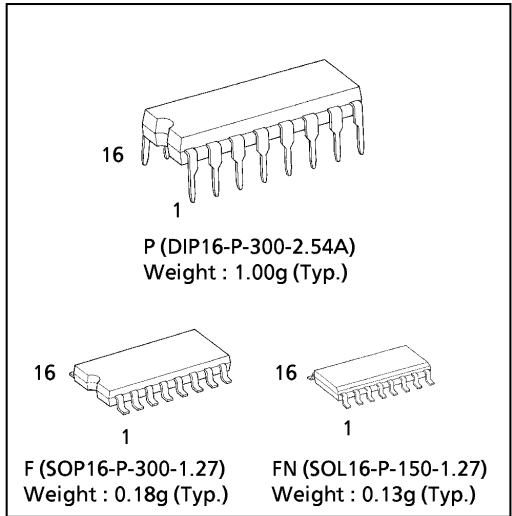

PIN ASSIGNMENT

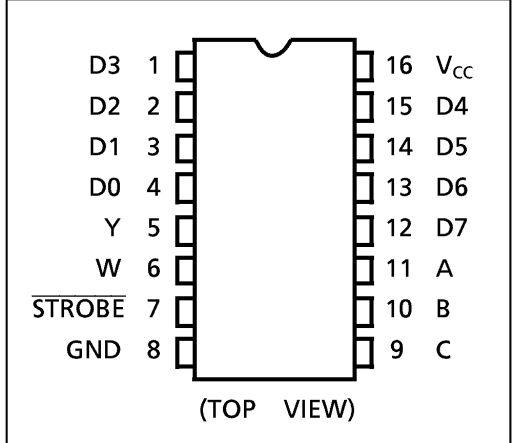

TRUTH TABLE

INPUTS			STROBE	OUTPUT	
SELECT				Y	W
C	B	A			
X	X	X	H	L	H
L	L	L	L	D0	$\overline{D0}$
L	L	H	L	D1	$\overline{D1}$
L	H	L	L	D2	$\overline{D2}$
L	H	H	L	D3	$\overline{D3}$
H	L	L	L	D4	$\overline{D4}$
H	L	H	L	D5	$\overline{D5}$
H	H	L	L	D6	$\overline{D6}$
H	H	H	L	D7	$\overline{D7}$

X : Don't Care

IEC LOGIC SYMBOL

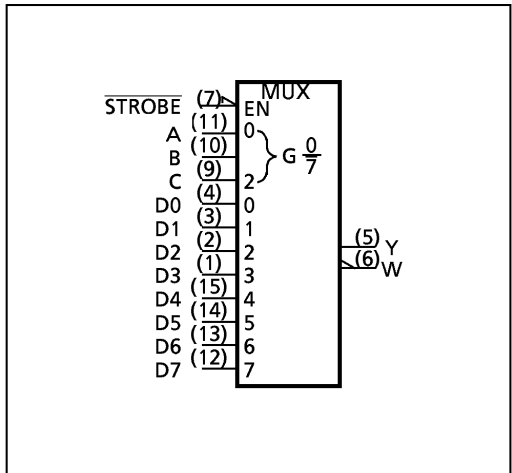

961001EBA2

● TOSHIBA is continually working to improve the quality and the reliability of its products. Nevertheless, semiconductor devices in general can malfunction or fail due to their inherent electrical sensitivity and vulnerability to physical stress. It is the responsibility of the buyer, when utilizing TOSHIBA products, to observe standards of safety, and to avoid situations in which a malfunction or failure of a TOSHIBA product could cause loss of human life, bodily injury or damage to property. In developing your designs, please ensure that TOSHIBA products are used within specified operating ranges as set forth in the most recent products specifications. Also, please keep in mind the precautions and conditions set forth in the TOSHIBA Semiconductor Reliability Handbook.

SYSTEM DIAGRAM

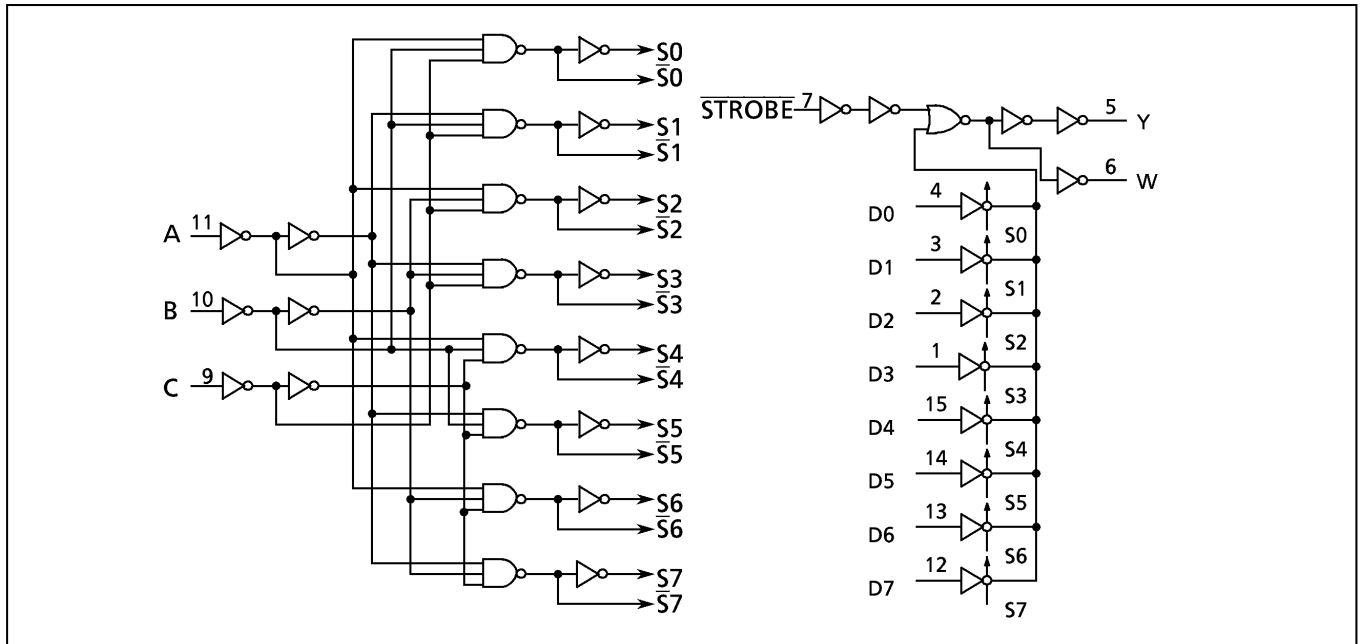

ABSOLUTE MAXIMUM RATINGS

PARAMETER	SYMBOL	VALUE	UNIT
Supply Voltage Range	V_{CC}	-0.5~7.0	V
DC Input Voltage	V_{IN}	-0.5~ $V_{CC}+0.5$	V
DC Output Voltage	V_{OUT}	-0.5~ $V_{CC}+0.5$	V
Input Diode Current	I_{IK}	± 20	mA
Output Diode Current	I_{OK}	± 50	mA
DC Output Current	I_{OUT}	± 50	mA
DC V_{CC} /Ground Current	I_{CC}	± 100	mA
Power Dissipation	P_D	500 (DIP)* / 180 (SOP)	mW
Storage Temperature	T_{stg}	-65~150	$^{\circ}C$

*500mW in the range of $T_a = -40^{\circ}C \sim 65^{\circ}C$. From $T_a = 65^{\circ}C$ to $85^{\circ}C$ a derating factor of $-10mW/^{\circ}C$ should be applied up to 300mW.

RECOMMENDED OPERATING CONDITIONS

PARAMETER	SYMBOL	VALUE	UNIT
Supply Voltage	V_{CC}	4.5~5.5	V
Input Voltage	V_{IN}	0~ V_{CC}	V
Output Voltage	V_{OUT}	0~ V_{CC}	V
Operating Temperature	T_{opr}	-40~85	$^{\circ}C$
Input Rise and Fall Time	dt/dV	0~10	ns/V

961001EBA2'

- The products described in this document are subject to foreign exchange and foreign trade control laws.
- The information contained herein is presented only as a guide for the applications of our products. No responsibility is assumed by TOSHIBA CORPORATION for any infringements of intellectual property or other rights of the third parties which may result from its use. No license is granted by implication or otherwise under any intellectual property or other rights of TOSHIBA CORPORATION or others.
- The information contained herein is subject to change without notice.

DC ELECTRICAL CHARACTERISTICS

PARAMETER	SYMBOL	TEST CONDITION	V _{CC} (V)	Ta = 25°C			Ta = -40~85°C		UNIT	
				MIN.	TYP.	MAX.	MIN.	MAX.		
High - Level Input Voltage	V _{IH}		4.5 } 5.5	2.0	—	—	2.0	—	V	
Low - Level Input Voltage	V _{IL}		4.5 } 5.5	—	—	0.8	—	0.8	V	
High - Level Output Voltage	V _{OH}	V _{IN} = V _{IH} or V _{IL}	I _{OH} = -50μA	4.5	4.4	4.5	—	4.4	—	V
			I _{OH} = -24mA	4.5	3.94	—	—	3.80	—	
			I _{OH} = -75mA *	5.5	—	—	—	3.85	—	
Low - Level Output Voltage	V _{OL}	V _{IN} = V _{IH} or V _{IL}	I _{OL} = 50μA	4.5	—	0.0	0.1	—	0.1	V
			I _{OL} = 24mA	4.5	—	—	0.36	—	0.44	
			I _{OL} = 75mA *	5.5	—	—	—	—	1.65	
Input Leakage Current	I _{IN}	V _{IN} = V _{CC} or GND	5.5	—	—	±0.1	—	±1.0	μA	
Quiescent Supply Current	I _{CC}	V _{IN} = V _{CC} or GND	5.5	—	—	8.0	—	80.0		
		I _C	PER INPUT : V _{IN} = 3.4V OTHER INPUT : V _{CC} or GND	5.5	—	—	1.35	—	1.5	mA

* : This spec indicates the capability of driving 50Ω transmission lines.
One output should be tested at a time for a 10ms maximum duration.

AC ELECTRICAL CHARACTERISTICS (C_L = 50pF , R_L = 500Ω , Input t_r = t_f = 3ns)

PARAMETER	SYMBOL	TEST CONDITION	V _{CC} (V)	Ta = 25°C			Ta = -40~85°C		UNIT
				MIN.	TYP.	MAX.	MIN.	MAX.	
Propagation Delay Time (D-Y, W)	t _{pLH}		5.0 ± 0.5	—	7.5	11.8	1.0	13.5	ns
	t _{pHL}		5.0 ± 0.5	—	9.5	15.8	1.0	18.0	
Propagation Delay Time (A, B, C-Y, W)	t _{pLH}		5.0 ± 0.5	—	6.3	10.1	1.0	11.5	
Propagation Delay Time (ST-Y, W)	t _{pHL}		5.0 ± 0.5	—	—	—	—	—	pF
Input Capacitance	C _{IN}		—	—	5	10	—	10	
Power Dissipation Capacitance	C _{PD} (1)		—	—	66	—	—	—	

Note(1) C_{PD} is defined as the value of the internal equivalent capacitance which is calculated from the operating current consumption without load.

Average operating current can be obtained by the equation :

$$I_{CC(opr.)} = C_{PD} \cdot V_{CC} \cdot f_{IN} + I_{CC}$$

DIP 16PIN OUTLINE DRAWING (DIP16-P-300-2.54A)

Unit in mm

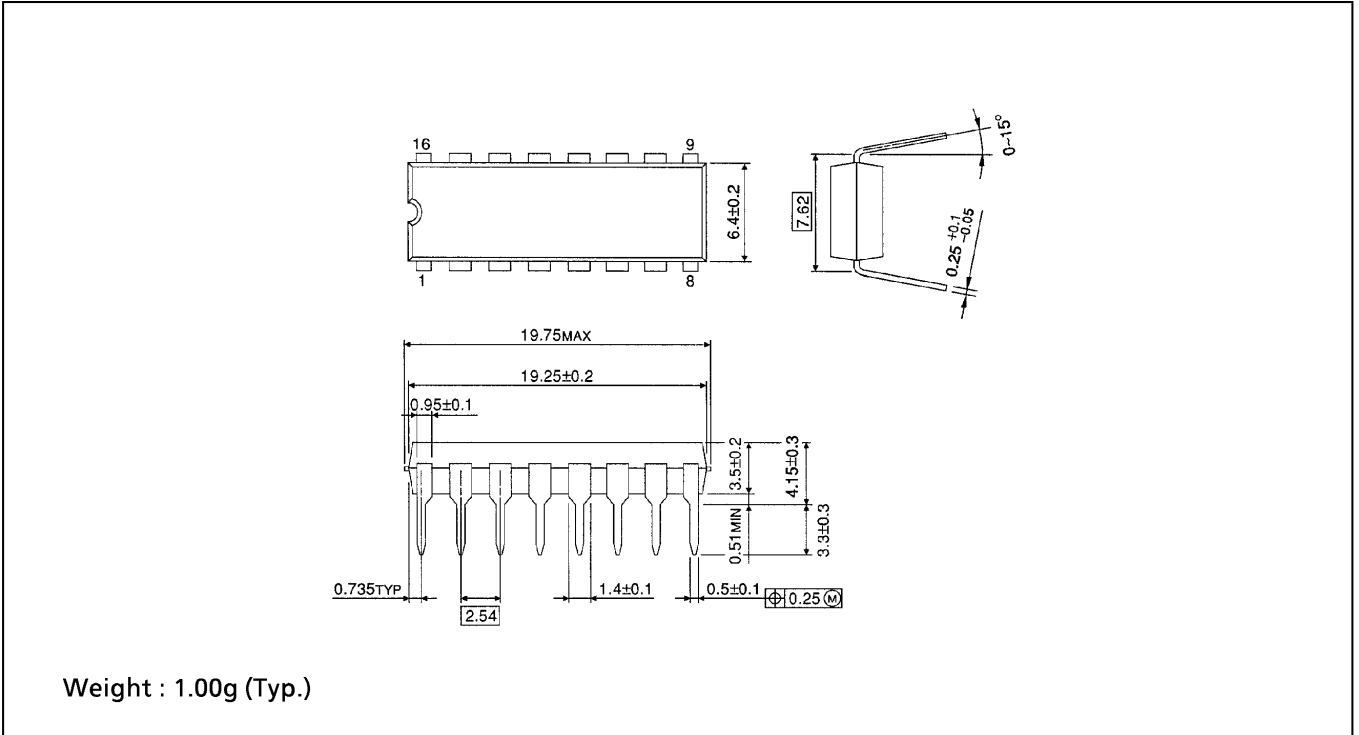

SOP 16PIN (200mil BODY) OUTLINE DRAWING (SOP16-P-300-1.27)

Unit in mm

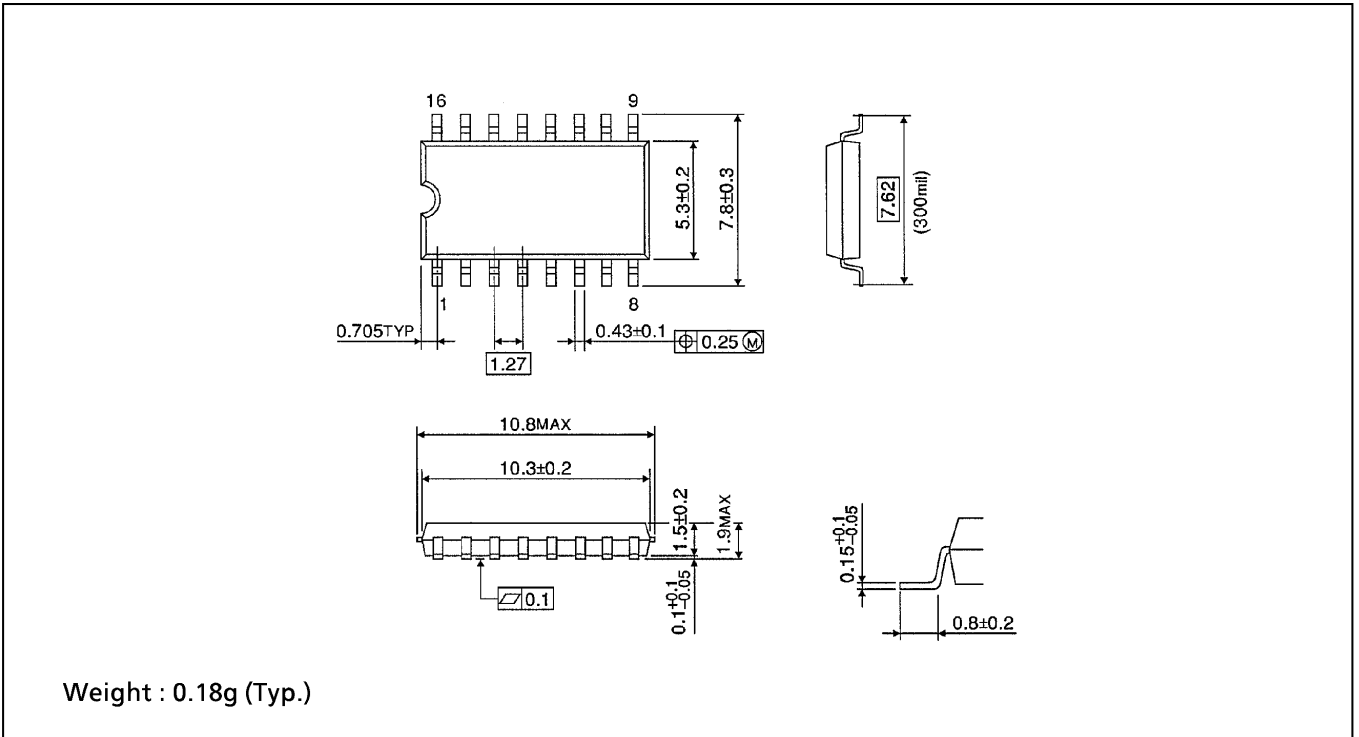

SOP 16PIN (150mil BODY) OUTLINE DRAWING (SOL16-P-150 -1.27)

Unit in mm

(Note) This package is not available in Japan.

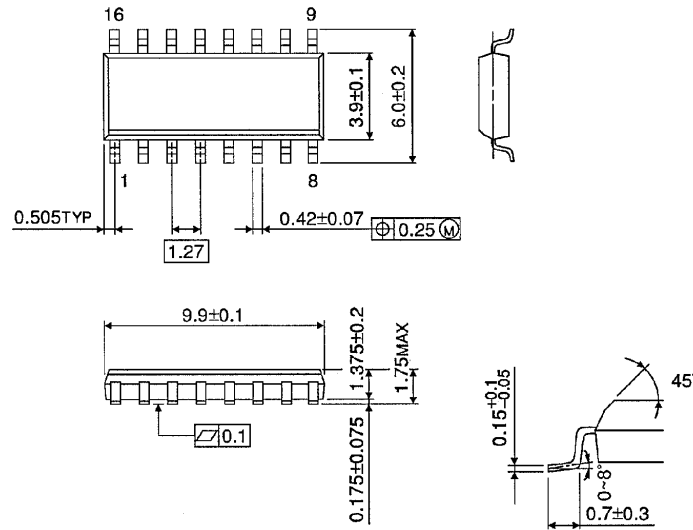

Weight : 0.13g (Typ.)