

Document Title

1Mx16 bit Page Mode Uni-Transistor Random Access Memory

Revision History

<u>Revision No.</u>	<u>History</u>	<u>Draft Date</u>	<u>Remark</u>
0.0	Initial Draft	December 12, 2003	Preliminary

The attached datasheets are provided by SAMSUNG Electronics. SAMSUNG Electronics CO., LTD. reserve the right to change the specifications and products. SAMSUNG Electronics will answer to your questions about device. If you have any questions, please contact the SAMSUNG branch offices.

K1S1616BCA

1M x 16 bit Page Mode Uni-Transistor CMOS RAM

FEATURES

- Process Technology: CMOS
- Organization: 1M x16 bit
- Power Supply Voltage: 1.7~2.1V
- Three State Outputs
- Compatible with Low Power SRAM
- Support 4 page read mode
- Package Type: 48-FBGA-6.00x7.00

GENERAL DESCRIPTION

The K1S1616BCA is fabricated by SAMSUNG's advanced CMOS technology using one transistor memory cell. The device support 4 page mode operation, Industrial temperature range and 48 ball Chip Scale Package for user flexibility of system design. The device also supports deep power down mode for low standby current.

PRODUCT FAMILY

Product Family	Operating Temp.	Vcc Range	Speed (trc)	Power Dissipation		PKG Type
				Standby (I _{SB1} , Max.)	Operating (I _{CC2} , Max.)	
K1S1616BCA-I	Industrial(-40~85°C)	1.7~2.1V	70/85ns	80µA	30mA	48-FBGA-6.00x7.00

PIN DESCRIPTION

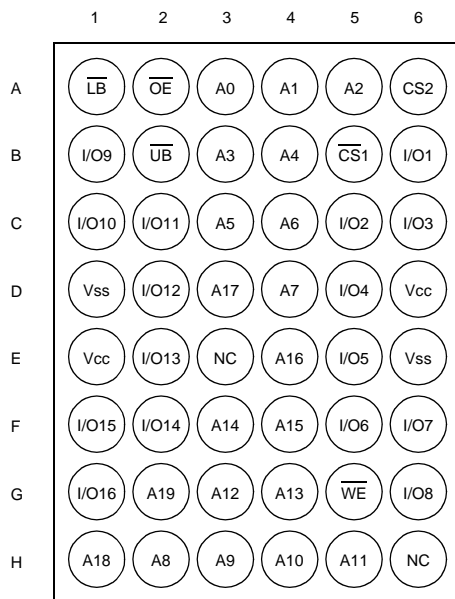

48-FBGA: Top View(Ball Down)

Name	Function	Name	Function
CS1,CS2	Chip Select Inputs	Vcc	Power
OE	Output Enable Input	Vss	Ground
WE	Write Enable Input	UB	Upper Byte(I/O9~16)
A0~A19	Address Inputs	LB	Lower Byte(I/O1~8)
I/O1~I/O16	Data Inputs/Outputs	NC	No Connection ¹⁾

1) Reserved for future use

FUNCTIONAL BLOCK DIAGRAM

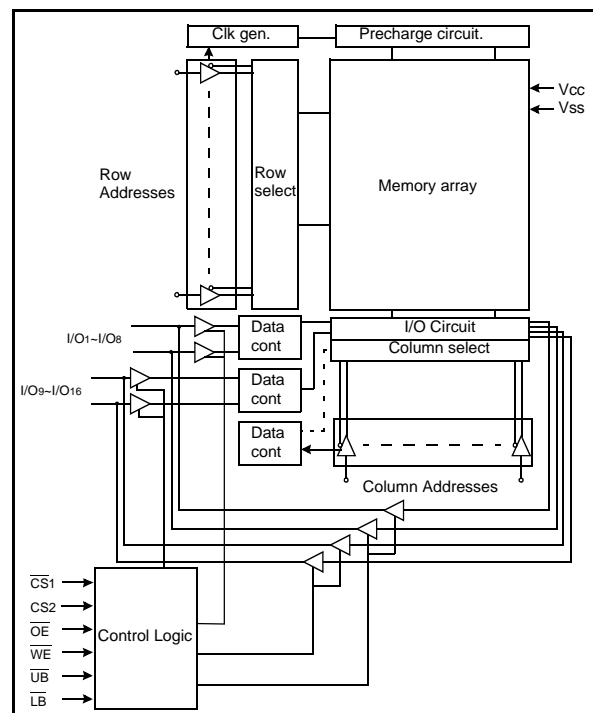

SAMSUNG ELECTRONICS CO., LTD. reserves the right to change products and specifications without notice.

K1S1616BCA

POWER UP SEQUENCE

1. Apply power.
2. Maintain stable power ($V_{CC} \text{ min.} = 1.7V$) for a minimum $200\mu s$ with $\overline{CS1} = \text{high}$, or $CS2 = \text{low}$.

TIMING WAVEFORM OF POWER UP(1) ($\overline{CS1}$ controlled)

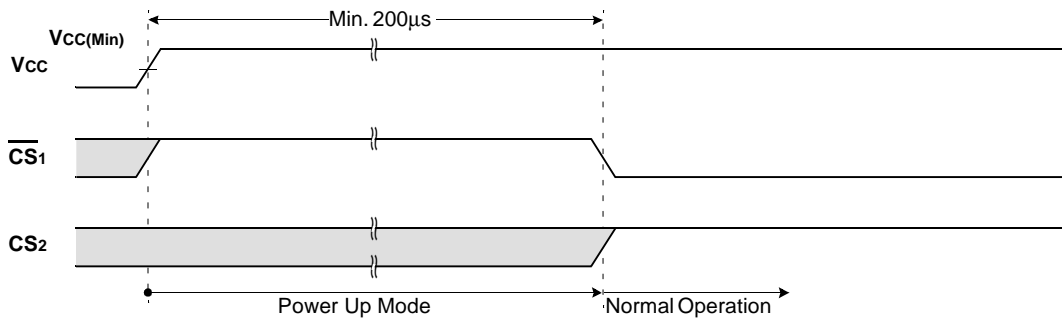

POWER UP(1)

1. After V_{CC} reaches $V_{CC(Min.)}$, wait $200\mu s$ with $\overline{CS1}$ high. Then the device gets into the normal operation.

TIMING WAVEFORM OF POWER UP(2) ($CS2$ controlled)

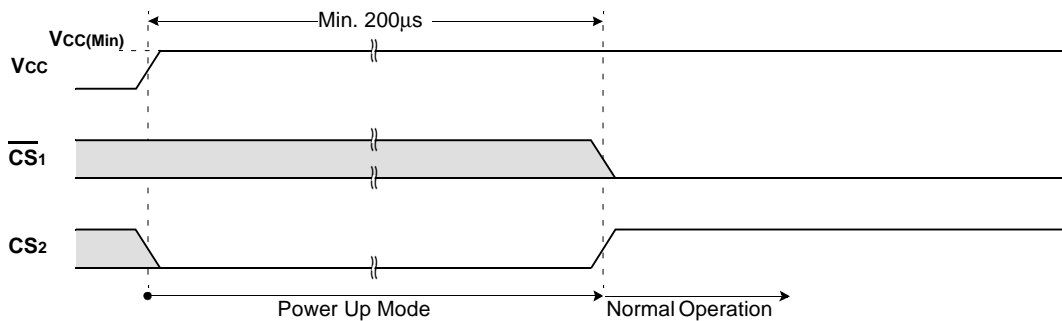

POWER UP(2)

1. After V_{CC} reaches $V_{CC(Min.)}$, wait $200\mu s$ with $CS2$ low. Then the device gets into the normal operation.

FUNCTIONAL DESCRIPTION

$\overline{CS1}$	$CS2$	\overline{OE}	\overline{WE}	\overline{LB}	\overline{UB}	I/O_{1-8}	I/O_{9-16}	Mode	Power
H	X ¹⁾	X ¹⁾	X ¹⁾	X ¹⁾	X ¹⁾	High-Z	High-Z	Deselected	Standby
X ¹⁾	L	X ¹⁾	X ¹⁾	X ¹⁾	X ¹⁾	High-Z	High-Z	Deselected	Standby
X ¹⁾	X ¹⁾	X ¹⁾	X ¹⁾	H	H	High-Z	High-Z	Deselected	Standby
L	H	H	H	L	X ¹⁾	High-Z	High-Z	Output Disabled	Active
L	H	H	H	X ¹⁾	L	High-Z	High-Z	Output Disabled	Active
L	H	L	H	L	H	Dout	High-Z	Lower Byte Read	Active
L	H	L	H	H	L	High-Z	Dout	Upper Byte Read	Active
L	H	L	H	L	L	Dout	Dout	Word Read	Active
L	H	X ¹⁾	L	L	H	Din	High-Z	Lower Byte Write	Active
L	H	X ¹⁾	L	H	L	High-Z	Din	Upper Byte Write	Active
L	H	X ¹⁾	L	L	L	Din	Din	Word Write	Active

1. X means don't care. (Must be low or high state)

ABSOLUTE MAXIMUM RATINGS¹⁾

Item	Symbol	Ratings	Unit
Voltage on any pin relative to V _{ss}	V _{IN} , V _{OUT}	-0.2 to V _{CC} +0.3V	V
Voltage on V _{CC} supply relative to V _{ss}	V _{CC}	-0.2 to 2.5V	V
Power Dissipation	P _D	1.0	W
Storage temperature	T _{STG}	-65 to 150	°C
Operating Temperature	T _A	-40 to 85	°C

1. Stresses greater than those listed under "Absolute Maximum Ratings" may cause permanent damage to the device. Functional operation should be restricted to be used under recommended operating condition. Exposure to absolute maximum rating conditions longer than 1 second may affect reliability.

PRODUCT LIST

Industrial Temperature Product(-40~85°C)	
Part Name	Function
K1S1616BCA-FI70	48-FBGA-6.00x7.00, 70ns
K1S1616BCA-FI85	48-FBGA-6.00x7.00, 85ns
K1S1616BCA-BI70 ¹⁾	48-FBGA-6.00x7.00, 70ns
K1S1616BCA-BI85 ¹⁾	48-FBGA-6.00x7.00, 85ns

1. Lead Free Product

RECOMMENDED DC OPERATING CONDITIONS¹⁾

Item	Symbol	Min	Typ	Max	Unit
Supply voltage	V _{CC}	1.7	1.8/2.0	2.1	V
Ground	V _{SS}	0	0	0	V
Input high voltage	V _{IH}	1.4	-	V _{CC} +0.3 ²⁾	V
Input low voltage	V _{IL}	-0.2 ³⁾	-	0.4	V

1. T_A=-40 to 85°C, otherwise specified.
2. Overshoot: V_{CC}+1.0V in case of pulse width ≤20ns.
3. Undershoot: -1.0V in case of pulse width ≤20ns.
4. Overshoot and undershoot are sampled, not 100% tested.

CAPACITANCE¹⁾(f=1MHz, T_A=25°C)

Item	Symbol	Test Condition	Min	Max	Unit
Input capacitance	C _{IN}	V _{IN} =0V	-	8	pF
Input/Output capacitance	C _{IO}	V _{IO} =0V	-	10	pF

1. Capacitance is sampled, not 100% tested.

DC AND OPERATING CHARACTERISTICS

Item	Symbol	Test Conditions	Min	Typ ¹⁾	Max	Unit
Input leakage current	I _{LI}	V _{IN} =V _{SS} to V _{CC}	-1	-	1	μA
Output leakage current	I _{LO}	$\overline{CS}=V_{IH}, \overline{ZZ}=V_{IH}, \overline{OE}=V_{IH}$ or $\overline{WE}=V_{IL}, V_{IO}=V_{SS}$ to V _{CC}	-1	-	1	μA
Average operating current	I _{CC1}	Cycle time=1μs, 100% duty, I _{IO} =0mA, $\overline{CS} \leq 0.2V$, $\overline{ZZ} \geq V_{CC}-0.2V$, V _{IN} ≤0.2V or V _{IN} ≥V _{CC} -0.2V	-	-	5	mA
	I _{CC2}	Cycle time=t _{RC} +3t _{PC} , I _{IO} =0mA, 100% duty, $\overline{CS}=V_{IL}, \overline{ZZ}=V_{IH}$, V _{IN} =V _{IL} or V _{IH}	-	-	30	mA
Output low voltage	V _{OL}	I _{OL} =0.1mA	-	-	0.2	V
Output high voltage	V _{OH}	I _{OH} =-0.1mA	1.4	-	-	V
Standby Current(CMOS)	I _{SB1} ²⁾	$\overline{CS} \geq V_{CC}-0.2V, \overline{ZZ} \geq V_{CC}-0.2V$, Other inputs=V _{SS} to V _{CC}	-	-	80	μA

1. Typical values are tested at V_{CC}=1.8V, T_A=25°C and not guaranteed.

AC OPERATING CONDITIONS

TEST CONDITIONS (Test Load and Test Input/Output Reference)

Input pulse level: 0.2 to $V_{CC}-0.2V$
 Input rising and falling time: 5ns
 Input and output reference voltage: $0.5 \times V_{CC}$
 Output load (See right): $C_L=50pF$

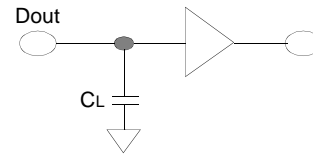

1. Including scope and jig capacitance

AC CHARACTERISTICS ($V_{CC}=1.7\sim 2.1V$, $T_A=-40$ to $85^\circ C$)

Parameter List		Symbol	Speed Bins				Units
			70ns		85ns		
			Min	Max	Min	Max	
Read	Read Cycle Time	t _{RC}	70	-	85	-	ns
	Address Access Time	t _{AA}	-	70	-	85	ns
	Chip Select to Output	t _{CO}	-	70	-	85	ns
	Output Enable to Valid Output	t _{OE}	-	35	-	40	ns
	\overline{UB} , \overline{LB} Access Time	t _{BA}	-	70	-	85	ns
	Chip Select to Low-Z Output	t _{LZ}	10	-	10	-	ns
	\overline{UB} , \overline{LB} Enable to Low-Z Output	t _{BLZ}	10	-	10	-	ns
	Output Enable to Low-Z Output	t _{OLZ}	5	-	5	-	ns
	Chip Disable to High-Z Output	t _{HZ}	0	25	0	25	ns
	\overline{UB} , \overline{LB} Disable to High-Z Output	t _{BHZ}	0	25	0	25	ns
	Output Disable to High-Z Output	t _{OHZ}	0	25	0	25	ns
	Output Hold from Address Change	t _{OH}	5	-	5	-	ns
	Page Cycle	t _{PC}	25	-	25	-	ns
Page Access Time	t _{PA}	-	20	-	20	ns	
Write	Write Cycle Time	t _{WC}	70	-	85	-	ns
	Chip Select to End of Write	t _{CW}	60	-	70	-	ns
	Address Set-up Time	t _{AS}	0	-	0	-	ns
	Address Valid to End of Write	t _{AW}	60	-	70	-	ns
	\overline{UB} , \overline{LB} Valid to End of Write	t _{BW}	60	-	70	-	ns
	Write Pulse Width	t _{WP}	55 ¹⁾	-	60 ¹⁾	-	ns
	Write Recovery Time	t _{WR}	0	-	0	-	ns
	Write to Output High-Z	t _{WHZ}	0	25	0	25	ns
	Data to Write Time Overlap	t _{DW}	30	-	35	-	ns
	Data Hold from Write Time	t _{DH}	0	-	0	-	ns
	End Write to Output Low-Z	t _{OW}	5	-	5	-	ns

1. t_{WP}(min)=70ns for continuous write operation over 50 times.

TIMING DIAGRAMS

TIMING WAVEFORM OF READ CYCLE(1)(Address Controlled, $\overline{CS}=\overline{OE}=V_{IL}$, $\overline{WE}=V_{IH}$, \overline{UB} or/and $\overline{LB}=V_{IL}$)

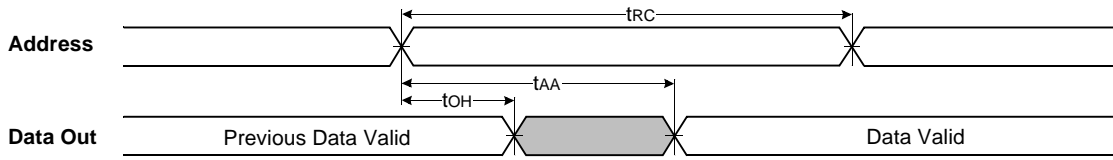

TIMING WAVEFORM OF READ CYCLE(2)($\overline{WE}=V_{IH}$)

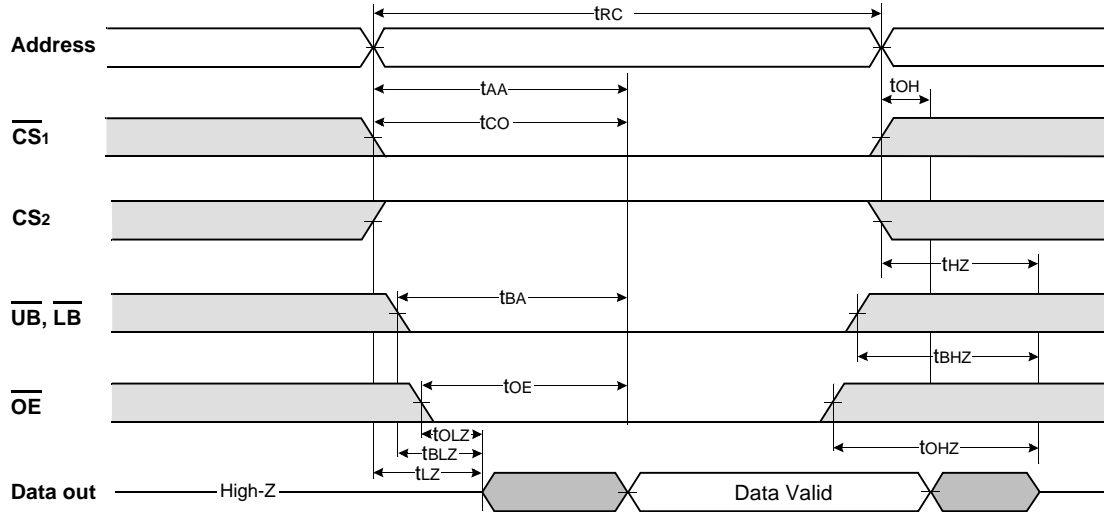

TIMING WAVEFORM OF PAGE CYCLE(READ ONLY)

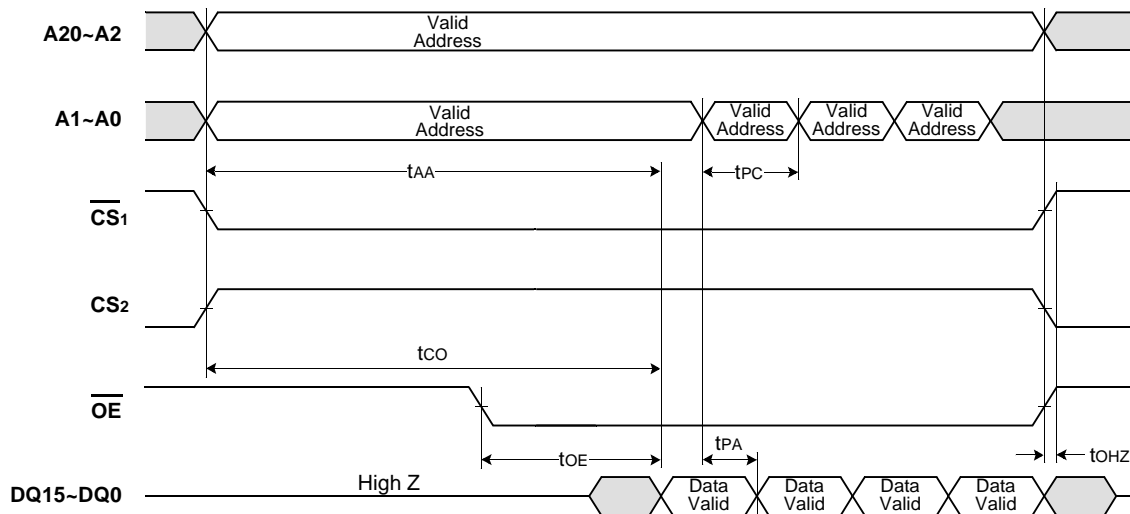

(READ CYCLE)

1. t_{HZ} and t_{OHZ} are defined as the time at which the outputs achieve the open circuit conditions and are not referenced to output voltage levels.
2. At any given temperature and voltage condition, $t_{HZ}(\text{Max.})$ is less than $t_{LZ}(\text{Min.})$ both for a given device and from device to device interconnection.
3. $t_{OE}(\text{max})$ is met only when \overline{OE} becomes enabled after $t_{AA}(\text{max})$.
4. If invalid address signals shorter than min. t_{RC} are continuously repeated for over 4 μs , the device needs a normal read timing(t_{RC}) or needs to sustain standby state for min. t_{RC} at least once in every 4 μs .

TIMING WAVEFORM OF WRITE CYCLE(1) (\overline{WE} Controlled)

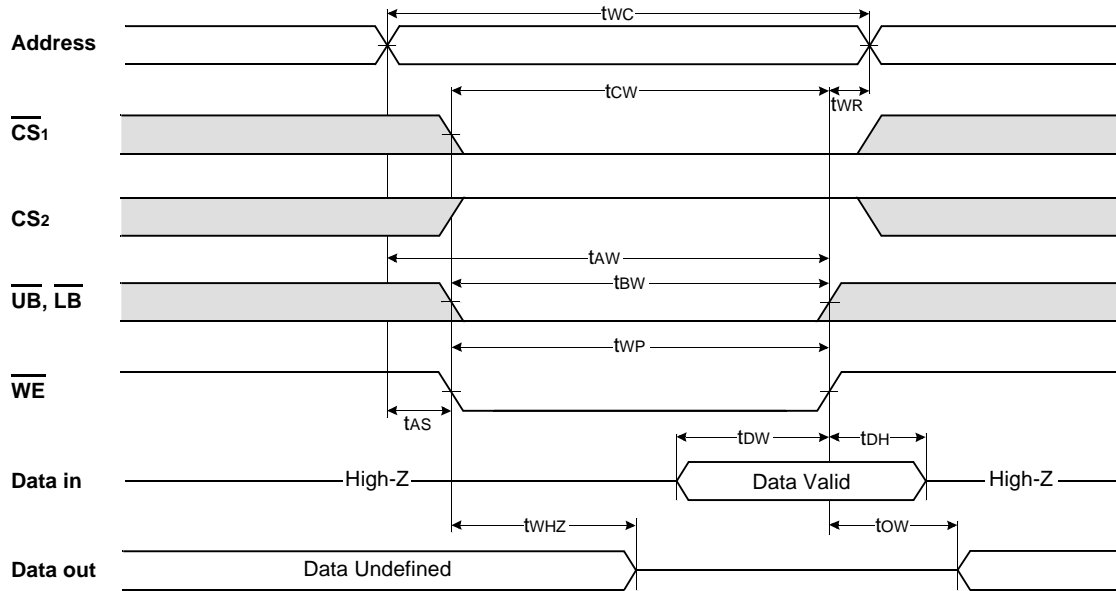

TIMING WAVEFORM OF WRITE CYCLE(2) ($\overline{CS1}$ Controlled)

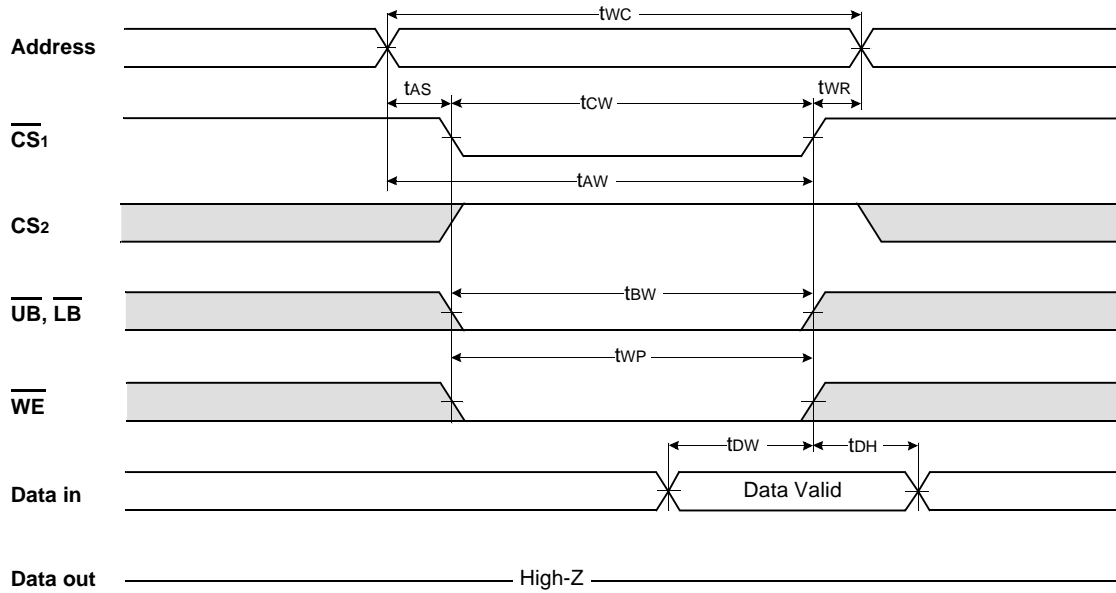

TIMING WAVEFORM OF WRITE CYCLE(3) (CS2 Controlled)

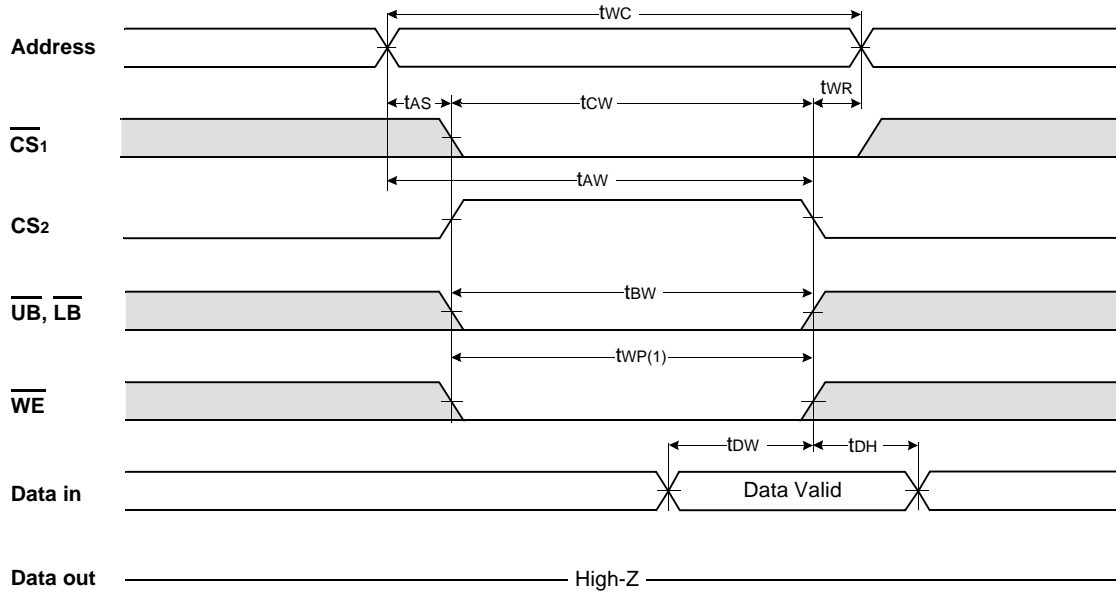

TIMING WAVEFORM OF WRITE CYCLE(4) (\overline{UB} , \overline{LB} Controlled)

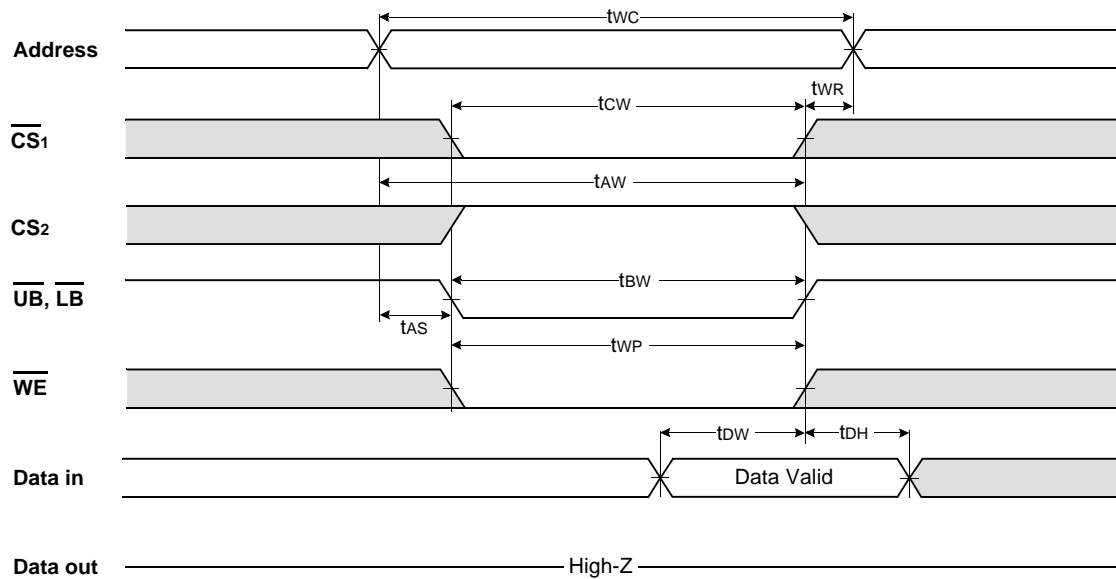

NOTES (WRITE CYCLE)

1. A write occurs during the overlap(tWP) of low $\overline{CS1}$ and low \overline{WE} . A write begins when $\overline{CS1}$ goes low and \overline{WE} goes low with asserting \overline{UB} or \overline{LB} for single byte operation or simultaneously asserting \overline{UB} and \overline{LB} for double byte operation. A write ends at the earliest transition when $\overline{CS1}$ goes high and \overline{WE} goes high. The tWP is measured from the beginning of write to the end of write.
2. tcw is measured from the $\overline{CS1}$ going low to the end of write.
3. tAS is measured from the address valid to the beginning of write.
4. tWR is measured from the end of write to the address change. tWR is applied in case a write ends with $\overline{CS1}$ or \overline{WE} going high.

PACKAGE DIMENSION

Unit: millimeters

48 BALL FINE PITCH BGA(0.75mm ball pitch)

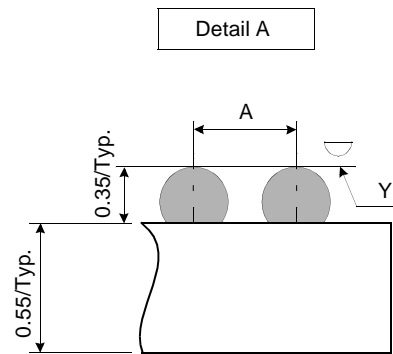
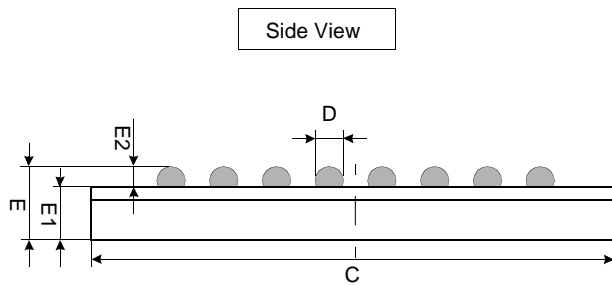
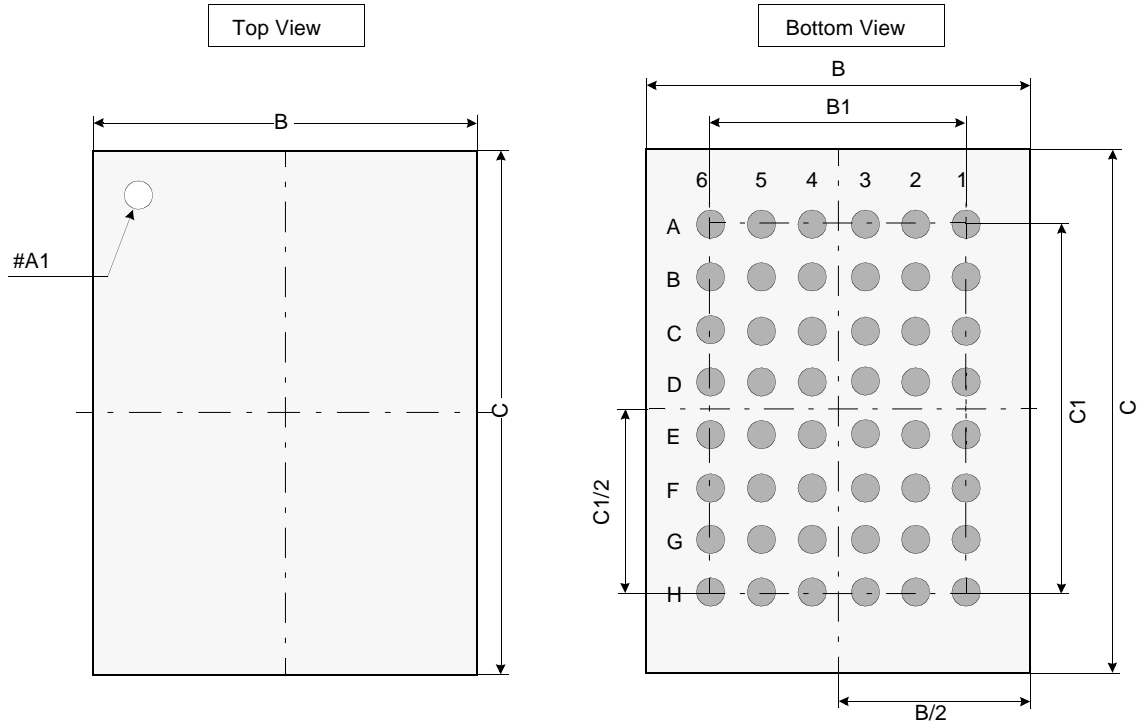

	Min	Typ	Max
A	-	0.75	-
B	5.90	6.00	6.10
B1	-	3.75	-
C	7.90	8.00	8.10
C1	-	5.25	-
D	0.40	0.45	0.50
E	-	0.90	1.00
E1	-	0.55	-
E2	0.30	0.35	0.40
Y	-	-	0.10

Notes.

1. Bump counts: 48(8 row x 6 column)
2. Bump pitch : (x,y)=(0.75 x 0.75)(typ.)
3. All tolerance are ± 0.050 unless specified beside figures.
4. Typ : Typical
5. Y is coplanarity: 0.10(Max)