

NCP5209

Product Preview

4-In-1 PWM Buck and Tri-Linear DDR Power Controller

The NCP5209 4-In-1 PWM Buck and Tri-Linear Power Controller is a complete ACPI compliant power solution for MCH and DDR memory. This IC combines the high efficiency of a PWM controller for the VDDQ supply with the simplicity of linear regulator for the VTT termination voltage as well as the MCH core supply voltage.

This IC contains a synchronous PWM buck controller for driving two external NFETs to form the DDR memory supply voltage (VDDQ). The DDR memory termination regulator (VTT) is designed to track at the half of reference voltage while sourcing and sinking current. The two linear regulator controllers driving two external NFETs are cascaded to produce the MCH core voltage (VMCH).

Protective features include, soft-start circuitry, under-voltage monitoring of 5VDUAL, 5VATX and 12VATX, and thermal shutdown. The IC is packaged in a QFN-20.

Features

- Synchronous PWM Buck Controller for VDDQ
- Integrated Power FETs with VTT Regulator Sourcing/Sinking up to 1.8 A
- Two Linear Regulator Drivers for VMCH
- All External Power MOSFETs are N-Channel
- Adjustable VDDQ and VMCH by External Dividers
- VTT Tracks at Half the Reference Voltage or can be Adjusted Externally
- Fixed Switching Frequency of 250 kHz for DDQ Regulator in Normal Mode Doubled switching frequency (500 kHz) for DDQ Regulator in Standby Mode
- Soft-Start Protection for all Regulators
- Under-Voltage Monitoring of Supply Voltages
- Over-Current Protection for DDQ and VTT Regulators
- Fully Complies with ACPI Power Sequencing Specifications
- Protects against Reverse DIMM Insertion
- Thermal Shutdown
- Housed in QFN-20

Applications

- DDR I and DDR II Memory and MCH Power Supply

This document contains information on a product under development. ON Semiconductor reserves the right to change or discontinue this product without notice.



ON Semiconductor®

<http://onsemi.com>

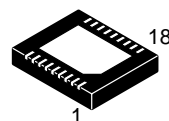

20-LEAD QFN
MN SUFFIX
CASE 505

MARKING DIAGRAM

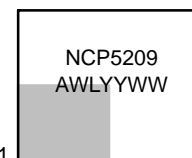

NCP5209 = Specific Device Code
A = Assembly Location
WL = Wafer Lot
YY = Year
WW = Work Week

PIN CONNECTIONS

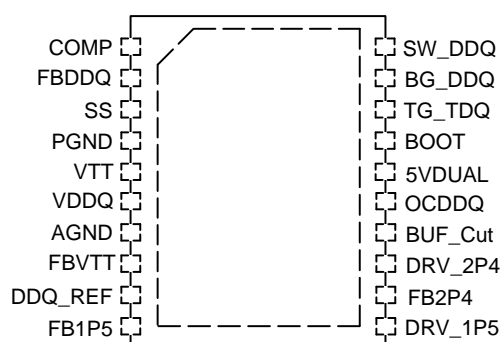

ORDERING INFORMATION

Device	Package	Shipping
NCP5209MN	20-Lead QFN*	Rail
NCP5209MNR2	20-Lead QFN*	Tape and Reel

*5 x 6 mm

NCP5209

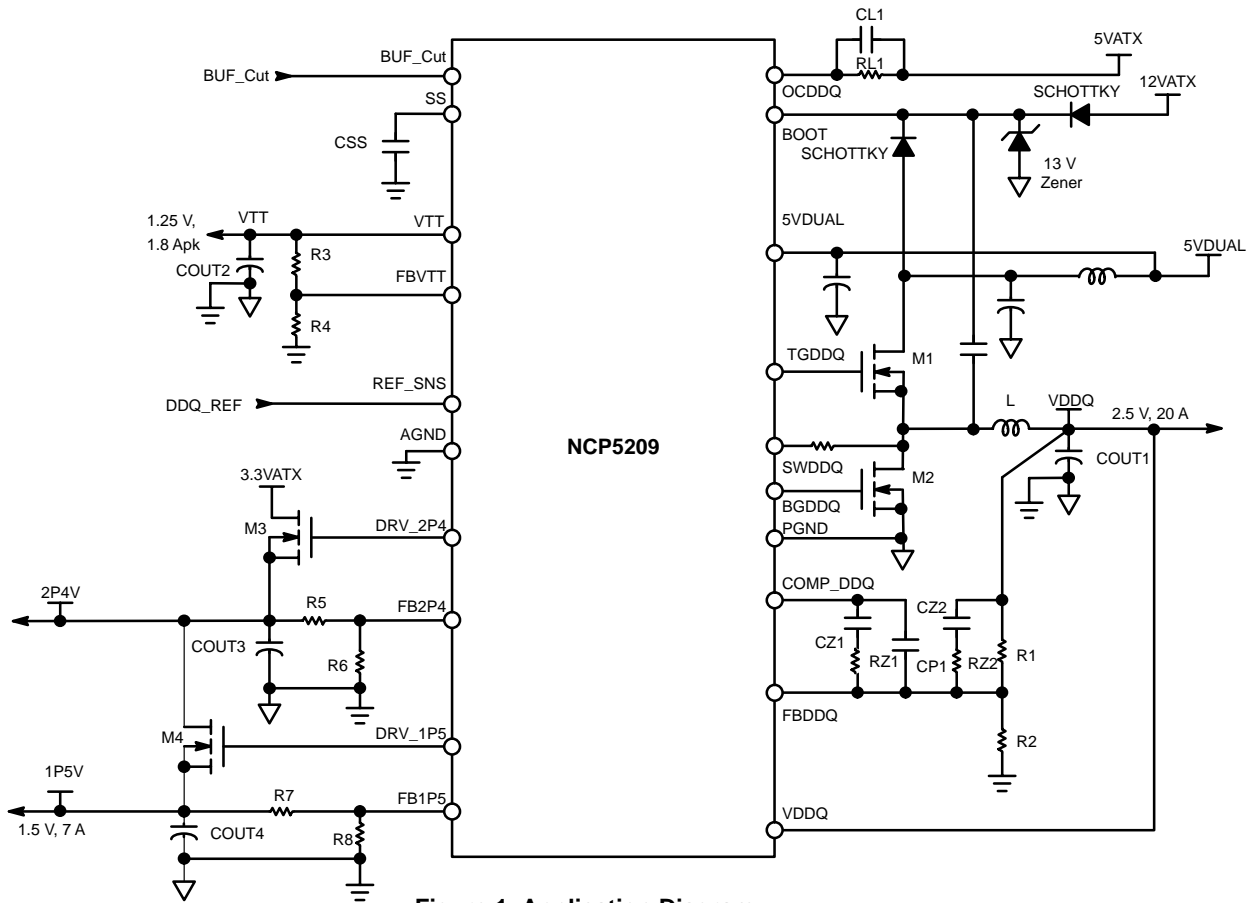

Figure 1. Application Diagram

NCP5209

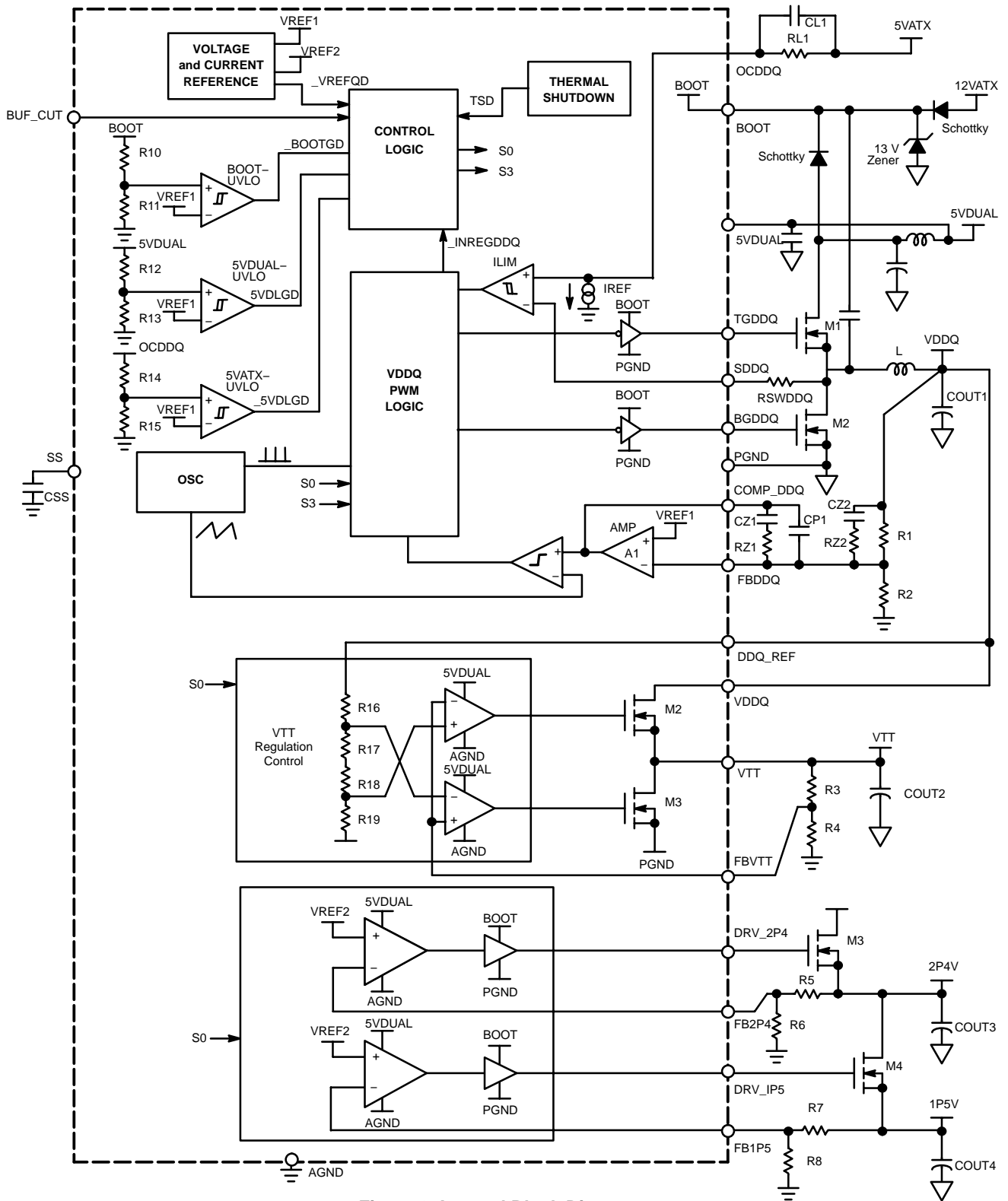

Figure 2. Internal Block Diagram.

NCP5209

PIN DESCRIPTION

Pin	Symbol	Descriptions
1	COMP	VDDQ Error Amplifier Compensation Node.
2	FBDDQ	VDDQ Regulator Feedback Pin for Closed Loop Regulation.
3	SS	Soft Start Capacitor Connection to Ground.
4	PGND	Power Ground
5	VTT	VTT Regulator Output
6	VDDQ	Power Input for VTT Linear Regulator
7	AGND	Analog Ground Connection and Remote Ground Sense.
8	FBVTT	VTT Linear Regulator Feedback pin for Closed Loop Regulation.
9	DDQ_REF	VDDQ Reference Voltage Input of VTT Regulator.
10	FB1P5	2nd Linear Regulator Feedback Pin for Closed Loop Regulation.
11	DRV_1P5	2nd Linear Regulator Gate Driver Output for N-Channel Power FET.
12	FB2P4	1st Linear Regulator Feedback Pin for Closed Loop Regulation.
13	DRV_2P4	1st Linear Regulator Gate Driver Output for N-Channel Power FET.
14	BUF_CUT	Active High Control Signal to Activate S3 Sleep State.
15	OCDDQ	Over-current Sense and Program Input for the VDDQ High Side FET.
16	5VDUAL	5 V Dual Supply Input
17	BOOT	Gate Driver Input Supply. A Boost Capacitor is Connected between SWDDQ and BOOT.
18	TGDDQ	Gate Driver Output for VDDQ Regulator High Side N-Channel Power FET.
19	BGDDQ	Gate Driver Output for VDDQ Regulator Low Side N-Channel Power FET.
20	SWDDQ	DDQ Regulator Current Limit Sense Input. A Protection Resistor Should be Connected between the Inductor Driven Node and SWDDQ.

MAXIMUM RATINGS

Rating	Symbol	Value	Unit
Power Supply Voltage (Pin 16) to AGND (Pin 7)	5VDUAL	-0.3, 6.0	V
Gate Drive Voltage (Pin 11, 13, 17-19) to AGND (PIN 7)	V_{CC}, V_g	-0.3, 14	V
Input / Output Pins to AGND (Pin 7) Pin 1-6, 8-10, 12, 14-15, 20	V_{IO}	-0.3, 6.0	V
Thermal Characteristics QFN-20 Plastic Package Thermal Resistance Junction-to-Air	$R_{\theta JA_Q}$	68	°C/W
Operating Junction Temperature Range	T_J	0 to + 150	°C
Operating Ambient Temperature Range	T_A	0 to + 70	°C
Storage Temperature Range	T_{stg}	- 55 to +150	°C
Moisture Sensitivity Level	MSL		

1. This device series contains ESD protection and exceeds the following tests:
Human Body Model (HBM) ≤ 2.0 kV per JEDEC standard: JESD22-A114.
Machine Model (MM) ≤ 200 V per JEDEC standard: JESD22-A115.
2. Latch-up Current Maximum Rating: ≤ 150 mA per JEDEC standard: JESD78.

NCP5209

ELECTRICAL CHARACTERISTICS

(5VDUAL = 5 V, BOOT = 12 V, 5VATX = 5 V, DDQ_REF = 2.5 V, T_A = 0 to 70°C, L = 1.7 μH, COUT1 = 3770 μF, COUT2 = 470 μF, COUT3 = 680 μF, COUT4 = 3300 μF, CSS = 33 nF, RL1 = 50 kΩ, R1 = 2.2 kΩ, R2 = 2 kΩ, R3 = 0 Ω, R4 = 1 kΩ, R5 = 10 kΩ, R6 = 5 kΩ, R7 = 6.8 Ω, R8 = 7.5 kΩ, RSWDDQ = 1 kΩ, RZ1 = 20 kΩ, RZ2 = 8 Ω, CP1 = 10 nF, CZ1 = 6.8 nF, CZ2 = 100 nF, for min/max values unless otherwise noted.)

Characteristic	Test Conditions	Symbol	Min	Typ	Max	Unit
----------------	-----------------	--------	-----	-----	-----	------

SUPPLY VOLTAGE

5VDUAL Operating Voltage		V5VDUAL	4.5	5.0	5.5	V
OCDDQ Operating Voltage		VOCDQ	4.5	5.0	5.5	V
BOOT Operating Voltage		VBOOT		12.0	13.2	V

Supply Current

S0 mode Supply Current from 5VDUAL	BUF_CUT = LOW, BOOT = 12 V, 5VATX = 5 V	I5VDL_S0			7	mA
S3 mode Supply Current from 5VDUAL	BUF_CUT = HIGH, 5VATX = 0 V	I5VDL_S3			5	mA
S5 mode Supply Current from 5VDUAL	BUF_CUT = LOW, 5VATX = 0 V	I5VDL_S5			1	mA
S0 mode Supply Current from BOOT	BUF_CUT = LOW, BOOT=12 V, 5VATX = 5 V, TGDDQ, BGDDQ, DRV_2P4 and DRV_1P5 Open	IBOOT_S0			40	mA
S3 mode Supply Current from BOOT	BUF_CUT = HIGH, 5VATX=0 V, TGDDQ, BGDDQ, DRV_2P4 and DRV_1P5 Open	IBOOT_S3			10	mA

Under-Voltage-Monitor

5VDUAL UVLO Upper Threshold		V5VDLUV+			4.4	V
5VDUAL UVLO Hysteresis		V5VDLhys		300		mV
BOOT UVLO Upper Threshold		VBOOTUV+			10.2	V
BOOT UVLO Hysteresis		VBOOTHys		1.0		V
OCDDQ UVLO Upper Threshold		OCDDQUV+			1.25	V
OCDDQ UVLO Hysteresis		OCDDQhys		200		mV

Thermal Shutdown

Thermal Shutdown		Tsd		140		°C
Thermal Shutdown Hysteresis		Tsdhys		25		°C

DDQ Switching Regulator

FBDDQ Feedback Voltage, Control Loop in Regulation	T _A = 25°C T _A = 0 to 70°C	VFBQ	1.178 1.166	1.190 1.190	1.202 1.214	V
Feedback Input Current	V(FBDDQ) = 1.190 V	IDDQfb			1	μA
Oscillator Frequency in S0 Mode		FDDQS0	225	250	275	kHz
Oscillator Frequency in S3 Mode		FDDQS3	450	500	550	kHz
OCDDQ pin Current Sink	V(OCDDQ) = 3 V	IOCDDQ	28	40	52	μA
Current Limit Blanking Time in S0 Mode		TDDQbk	400			ns
Minimum Duty Cycle in S0 Mode		DS0min	0			%
Maximum Duty Cycle in S0 Mode		DS0max			100	%

DDQ Switching Regulator

Minimum Duty Cycle in S3 Mode		DS3min	0			%
Maximum Duty Cycle in S3 Mode		DS3max			90	%
Soft-Start Timing		Tss1		10		ms

DDQ ERROR AMPLIFIER

DC Gain		GAINDDQ		70		dB
---------	--	---------	--	----	--	----

NCP5209

ELECTRICAL CHARACTERISTICS

(5VDUAL = 5 V, BOOT = 12 V, 5VATX = 5 V, DDQ_REF = 2.5 V, T_A = 0 to 70°C, L = 1.7 μH, COUT1 = 3770 μF, COUT2 = 470 μF, COUT3 = 680 μF, COUT4 = 3300 μF, CSS = 33 nF, RL1 = 50 kΩ, R1 = 2.2 kΩ, R2 = 2 kΩ, R3 = 0 Ω, R4 = 1 kΩ, R5 = 10 kΩ, R6 = 5 kΩ, R7 = 6.8 Ω, R8 = 7.5 kΩ, RSWDDQ = 1 kΩ, RZ1 = 20 kΩ, RZ2 = 8 Ω, CP1 = 10 nF, CZ1 = 6.8 nF, CZ2 = 100 nF, for min/max values unless otherwise noted.)

Characteristic	Test Conditions	Symbol	Min	Typ	Max	Unit
----------------	-----------------	--------	-----	-----	-----	------

DDQ ERROR AMPLIFIER

Gain–Bandwidth Product	COMP_DDQ = 220 nF, 1 Ω in Series	GBWDDQ		TBD		MHz
Slew Rate	COMP_DDQ = 10 pF	SRDDQ		8		V/μs

VTT Active Termination Regulator

VTT tracking REF_SNS/2 at S0 mode	IOUT= 0 to 1.8 A (Sink Current) IOUT= 0 to –1.8 A (Source Current)	adVTTS0	–30		30	mV
VTT Source Current Limit		ILIMVTSrc		2.4		A
VTT Sink Current Limit		ILIMVTSnk		2.4		A
DDQ_REF Input Resistance		RDDQ_REF		50		Ω

Dual Linear Regulator Controller

1st Regulator Feedback Voltage, Control Loop in Regulation	T _A = 0°C to 70°C	VFB2P4	0.784	0.800	0.816	V
1st Regulator Feedback Input Current		IFB2P4			1	μA
1st Regulator DC Gain		GAIN2P4		66		dB
2nd Regulator Feedback Voltage, Control Loop in Regulation	T _A = 0°C to 70°C	VFB1P5	0.784	0.800	0.816	V
2nd Regulator Feedback Input Current		IFB1P5			1	μA
2nd Regulator DC Gain		GAIN1P5		66		dB
Internal Soft–Start Timing		Tss2		1.5		ms

Control Section

BUF_CUT Input Logic HIGH		Logic_H	2.0			V
BUF_CUT Input Logic LOW		Logic_L			0.8	V
BUF_CUT Input Current		ILogic			1	μA

Gate Drivers

TGDDQ Gate Pull–HIGH Resistance	BOOT = 12 V, V(TGDDQ) = 11.9 V	RH_TG		3.5		Ω
TGDDQ Gate Pull–LOW Resistance	BOOT = 12 V, V(TGDDQ) = 0.1 V	RL_TG		2.5		Ω
BGDDQ Gate Pull–HIGH Resistance	BOOT = 12 V, V(BGDDQ) = 11.9 V	RH_BG		3.5		Ω
BGDDQ Gate Pull–LOW Resistance	BOOT = 12 V, V(BGDDQ) = 0.1 V	RL_BG		1.3		Ω
DRV_2P4 Gate Pull–HIGH Voltage	BOOT = 12 V	VH2P4		9.0		V
DRV_2P4 Gate Pull–LOW Voltage	BOOT = 12 V	VL2P4		0.8		V
DRV_2P4 Gate Source Current	BOOT = 12 V	IH2P4		10		mA
DRV_2P4 Gate Sink Current	BOOT = 12 V	IL2P4		10		mA
DRV_1P5 Gate Pull–HIGH Voltage	BOOT = 12 V	VH1P5		9.0		V
DRV_1P5 Gate Pull–LOW Voltage	BOOT = 12 V	VL1P5		0.8		V
DRV_1P5 Gate Source Current	BOOT = 12 V	IH1P5		10		mA
DRV_1P5 Gate Sink Current	BOOT = 12 V	IL1P5		10		mA

DETAILED OPERATION DESCRIPTIONS

General

The NCP5209 4–In–1 PWM Buck and Tri–Linear DDR Power Controller contains a high efficiency PWM controller, an integrated two–quadrant linear regulator and two linear regulator controllers.

The VDDQ supply is generated by a PWM controller driving two external NFETs. The VTT termination voltage is tracked by an integrated linear regulator with sourcing and sinking current capability. The dual linear controllers driving two external NFETs can either be cascaded to create the MCH core voltage or work independently to produce two regulated output voltages. All regulator outputs are adjustable.

The inclusion of soft–start, supply under–voltage monitors, over–current protection and thermal shutdown, makes this device a complete power solution for the MCH and DDR memory system. This device is packaged in QFN–20.

ACPI Control Logic

The ACPI control logic is powered by the 5VDUAL supply input. The BUF_CUT input and the three supply voltage monitoring signals from the internal UVLOs are used to decode the operating mode in accordance with the state transition diagram shown in Figure 5. The 5VDUAL supply must come up before the other supplies.

The UVLOs monitor the motherboard supplies 5VDUAL, 12VATX and 5VATX through the 5VDUAL, BOOT and OCDDQ pins respectively. Three control signals, _5VDUALGD, _BOOTGD and _OCDDQGD, are asserted when the supply voltages are in good condition.

When the device is first powered up, it is in S5 shutdown mode to minimize the power consumption. When all three supplies are good and BUF_CUT is LOW the device enters

S0 normal operating mode, in which, all regulators are running.

The transition of BUF_CUT from LOW to HIGH in S0 mode triggers the device into the S3 sleep mode. In S3 mode, the external 12VATX and 5VATX supplies collapse and only the VDDQ regulator is working.

During S3 mode, the transition of BUF_CUT from HIGH to LOW triggers the device back to S0 mode providing 12ATX and 5VATX are good. The IC can re–enter S5 mode from S0 mode by removing one of the supplies. Transitions from S3 to S5 or vice versa are not allowed. A timing diagram is shown in Figure 4.

Table 1 summarizes the operating states of all regulators and the conditions of the output pins.

S5–To–S0 Mode Power Up Sequence

An internal bandgap reference is generated whenever 5VDUAL exceeds 2.7 V. Once this bandgap reference is in regulation, an internal signal _VREFGD is asserted to wake up the ACPI logic.

The assertion of VREFGD enables the ACPI control logic. Once the ACPI control is activated, the power up sequence starts by waking up the 5VDUAL voltage monitor block and reference current generator first. After 5VDUAL is within the preset level, the BOOT and OCDDQ under voltage monitor blocks are enabled to detect the presence of the 12VATX and 5VATX supplies. When the three supplies are in regulation and BUFCUT is LOW the device enters S0 mode by activating the soft–start of VDDQ switching regulator.

After the VDDQ regulator is in regulation and the soft–start interval is completed, the _INREGDDQ signal is asserted to wake up the VTT regulator and the dual linear controllers.

Table 1. Mode, Operation and Output Pin Condition

MODE	OPERATING CONDITIONS			OUTPUT PIN CONDITIONS			
	DDQ	VTT	Dual Linear	TGDDQ	BGDDQ	DRV_2P4	DRV_1P5
S0	Normal	Normal	Normal	Normal	Normal	Normal	Normal
S3	Standby	H–Z	H–Z	Standby	Standby	Low	Low
S5	H–Z	H–Z	H–Z	Low	Low	Low	Low

VDDQ Switching Regulator

The VDDQ regulator in S0 mode is a synchronous buck controller that drives two external power NFETs to supply up to 25 A. It employs the voltage mode fixed frequency PWM control scheme with external compensation switching at $250 \text{ kHz} \pm 10\%$. As shown in Figure 2, the VDDQ output voltage is divided down and fed back to the inverting input of an amplifier through the FBDDQ pin to close the loop at $VDDQ = VFBQ \times (1 + R2/R1)$. This amplifier compares the feedback voltage with an internal VREF1 (=1.190 V) to generate an error signal for the PWM comparator. This error signal is further compared with a fixed frequency RAMP waveform to generate a PWM signal. This PWM signal drives the external NFETs via the TG_DDQ and BG_DDQ pins. External inductor L and capacitor COUT1 filter the output voltage. When the NCP5209 leaves S5 mode, the VDDQ output voltage ramps up at a rate controlled by the capacitor at the SS pin. When VDDQ is regulating in S0 mode, a signal _INREGDDQ goes HIGH.

In S3 standby mode, the switching frequency is doubled to reduce the conduction loss in the external NFETs.

Tolerance of VDDQ

Both the tolerance of VFBDDQ and the ratio of external resistor divider R2/R1 impact the precision of VDDQ. When the control loop is in regulation, $VDDQ = VFBQ \times (1 + R2/R1)$. With a worst case (for all valid operating conditions) VFBDDQ tolerance of $\pm 2.0\%$, a worst case range of $\pm 2.5\%$ for VDDQ can be assured if the ratio R2/R1 is specified as $1.10 \pm 1\%$.

Fault Protection of VDDQ Regulator

In S0 mode, an external resistor (RL1) connecting the 5VATX supply to the OCDDQ pin sets the current limit for the high-side switch. An internal 40 μA current sink at the OCDDQ pin establishes a voltage drop across this resistor. The inductor node voltage is sensed at the SWDDQ pin through a resistor (RSWDDQ). The voltage at the OCDDQ pin is compared to the voltage at the SWDDQ pin when the high-side FET is turned on after a fixed period of blanking time thus avoiding false current limit triggering. If the voltage at SW_DDQ is lower than that at OCDDQ, an over-current condition occurs, during which, all regulators are latched off to protect against over-current. The IC can be powered up again only if any one of supply voltages (5VDUAL, 12VATX or 5VATX) is recycled or the SS pin is discharged to ground externally.

Since the OCDDQ pin is also used for detecting the 5VATX power supply, the upper threshold of the 5VATX UVLO is set to 1.25 V. Therefore, RL1 must be selected in such a way that the voltage at the OCDDQ pin must be higher than this threshold to avoid false triggering of the UVLO.

In S3 mode, this over-current protection feature is disabled.

Feedback Compensation of VDDQ Regulator

The compensation network is shown in Figure 2.

VTT Active Terminator

The VTT active terminator is a two quadrant linear regulator with two internal NFETs to provide current sink and source capability up to 1.8 A. It is active only when the VDDQ regulator is in regulation in S0 mode. It draws power from VDDQ with the internal gate drive power derived from 5VDUAL. While the VTT output is directly connected to the FBVTT pin, the VTT voltage is designed to automatically track at the half of the DDQ_REF voltage. This VTT voltage can be adjusted by using an external resistor divider in the feedback loop. This regulator is stable with any value of output capacitor greater than 470 μF , and is insensitive to ESR ranging from 1 $\text{m}\Omega$ to 400 $\text{m}\Omega$.

Fault Protection of VTT Active Terminator

To provide protection for the internal FETs, a bi-directional current limit set to 2.4 A is implemented. This current limit is also used as a constant current source during VTT startup.

Dual Linear Regulators

The dual linear regulators are formed by two high-gain controllers driving external NFETs. They are activated after the DDQ regulator is in regulation in S0 mode. The output voltage of each regulator is fed back through an external resistor divider. The feedback voltage is compared to an internal reference voltage VREF2 (=0.800 V) to achieve voltage regulation.

Both linear regulators use a common soft-start ramp voltage set to 1.5 ms. Once they are activated, hiccup mode is employed during the soft-start period to protect them against short circuit or power failure conditions. In the soft-start interval, the feedback voltages of both regulators are compared with the soft-start ramping voltage. If either one of feedback voltages is 100 mV below the SS ramping voltage, a short circuit or power failure condition is detected,

causing both regulators to be reset and initiate the soft start sequence again, as depicted in Figure 3. This hiccup mode feature is disabled once after both outputs are in regulation.

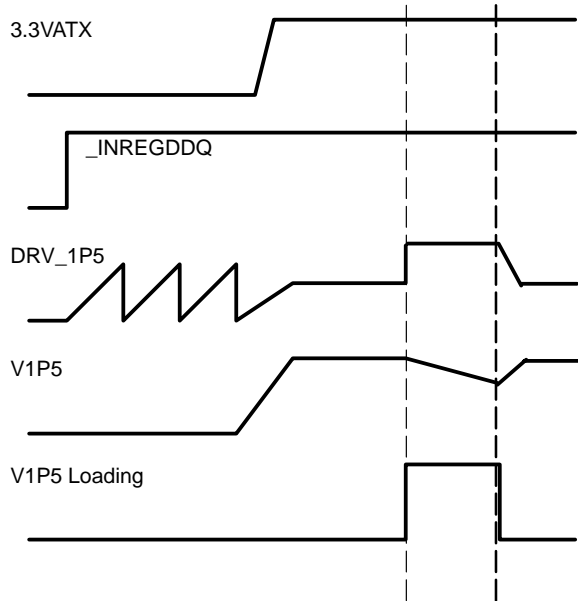

Figure 3. Hiccup Mode Soft-start of Dual Linear Regulators

These two linear regulators can be cascaded to generate the 1.5 V MCH core voltage with 2.4 V as the intermediate voltage. By using the 3.3 V ATX as the power supply for the external NFETs, up to 7 A can be delivered.

If only one linear regulator is used, it is recommended to pull the feedback pin of the unused regulator to 5VDUAL to

reduce the internal power consumption as well as to avoid soft-start issues.

Fault Protection of Dual Linear Regulators

Internal soft-start is built-in to limit the in-rush current.

BOOT Pin Supply Voltage

In a typical application, a flying capacitor is connected between the inductor LX node and the BOOT pin. In S0 mode, the 12VATX supply is tied to the BOOT pin through a Schottky diode. A 13 V zener diode must be put as close to the BOOT pin as possible to clamp the boot strapping voltage produced by the flying capacitor.

In S3 mode the 12VATX supply is collapsed. The BOOT voltage is created by the Schottky diode between 5VDUAL and BOOT pins and the flying capacitor.

Thermal Consideration

Assuming an ambient temperature of 50°C, the maximum allowed dissipated power of the QFN-20 package is 1.45 W. Thus a maximum of 0.8 A of DC current can be handled by the VTT regulator in S0 mode. To take full advantage of the thermal capability of this package, the exposed pad underneath must be soldered directly onto a PCB metal substrate to allow good thermal contact.

Thermal Shutdown

The device will enter S5 mode from any operating mode if the junction temperature of the NCP5209 exceeds 140°C. It will resume normal operation (from S5 to S0 mode) when the junction temperature falls below 115°C.

Power Up and Power Down Timing

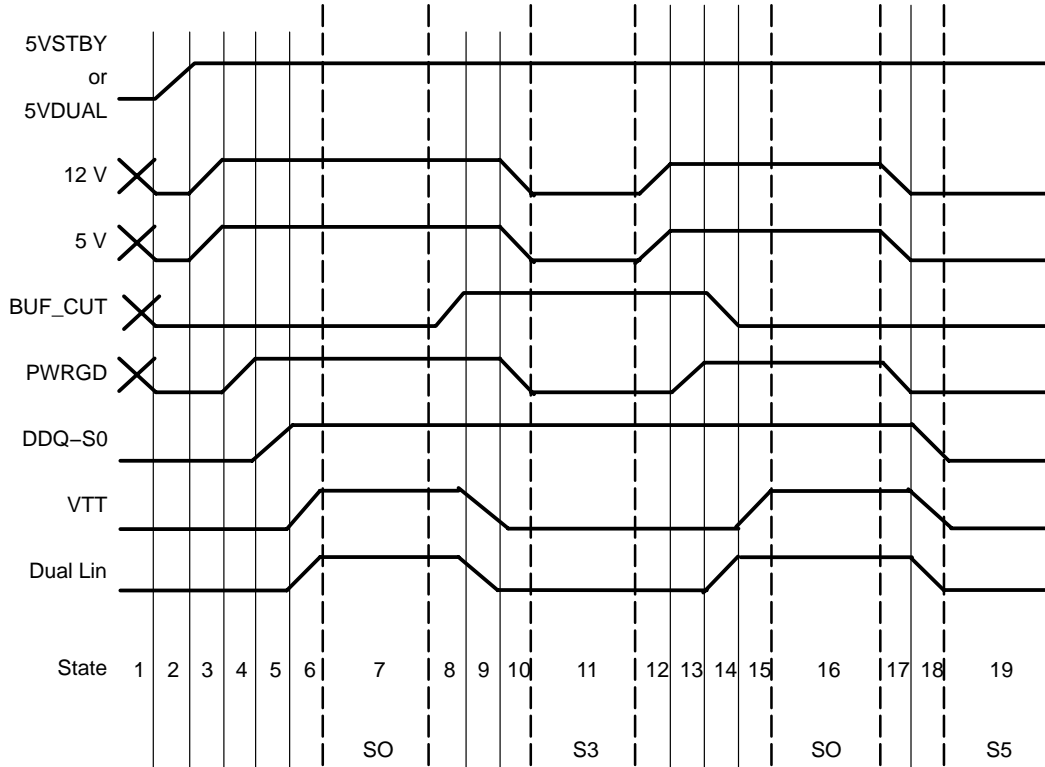

- 1 5VSTBY or 5VSTB is ultimate chip enable. This supply has to be up first to ensure gates are in known state.
- 3 12 V and 5 V Supplies can Ramp in Either Order
- 4 PWRGD asserts to indicate 5VDUAL has switched to 5VCC
- 5 DDQ ramps up with timing set by the SS pin
- 6 MCH and VTT both ramp once DDQ SS is completed and DDQ is within 90% of regulated voltage
- 7 SO Operation
- 8 Prepare S3 Mode -- BUF_CUT = H
- 9 VTT and MCH will be turned off
- 10 12V and 5V ramp down to 0 volts, so as PWRGD
- 11 Standard S3 State
- 12 12V and 5V ramp back to regulation
- 13 PWRGD ramps up to indicate that 5VDUAL has switched to 5VCC
- 14 DDQ switches back to 250kHz and MCH ramps up
- 15 VTT ramps up after BUF_CUT goes LOW
- 16 SO Operation
- 17 S5 mode -- BUF_CUT = L and (12VUVLO = L or 5VUVLO = L)
- 18 DDQ, VTT and MCH turned off
- 19 S5 Mode

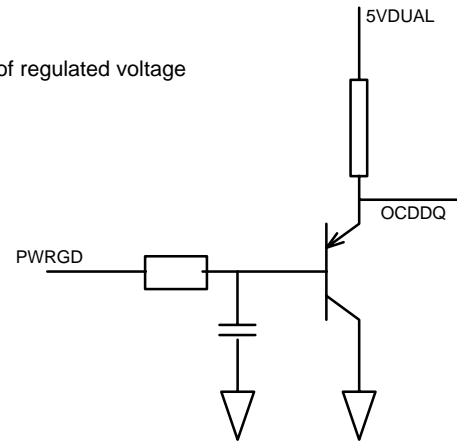
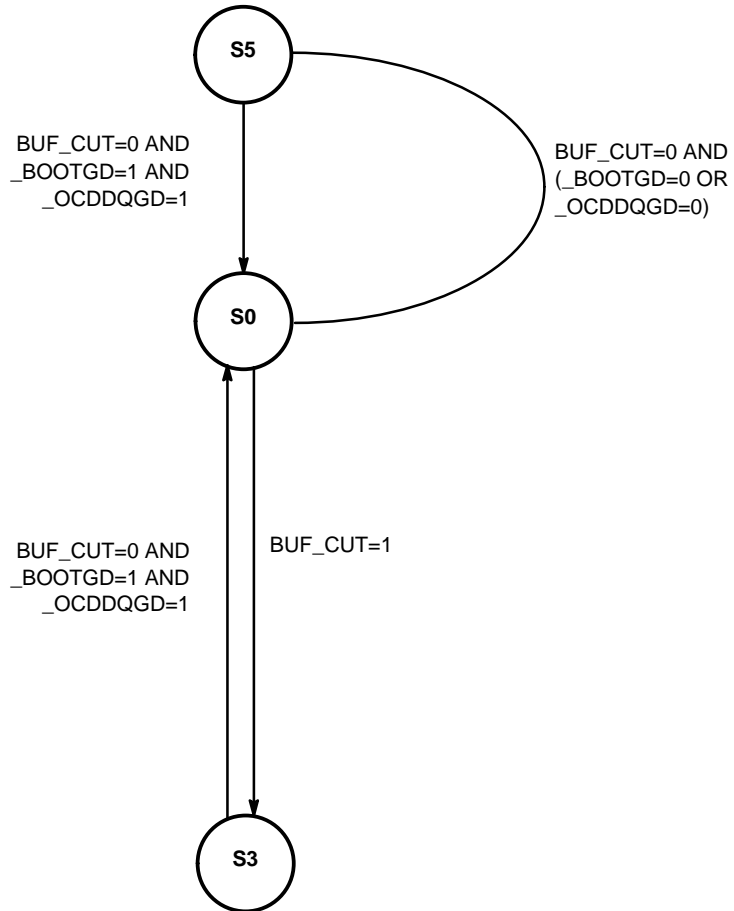

Figure 4. Timing Diagram

State Transition Diagram



NOTES: Note: 5VDUAL is assumed to be in good conditions in any mode.
 All possible state transitions are shown.
 All unspecified inputs do not cause any state change.

Figure 5. State Transition Diagram.

Applications Information

In some systems, the switching of 5VDUAL from 5VSTBY to 5VATX or vice versa does not automatically occur during mode transitions. To avoid overloading the 5VSTBY supply, a PWRGD signal, which is asserted only when 5VDUAL has been switched over to 5VATX, is created. This PWRGD signal is then used for controlling one of the UVLOs of this device so that the device can only enter S0 after the 5VDUAL has been switched over to 5VATX.

NCP5209

PACKAGE DIMENSIONS

[Package Designation]
MN SUFFIX
CASE 505-01
ISSUE A

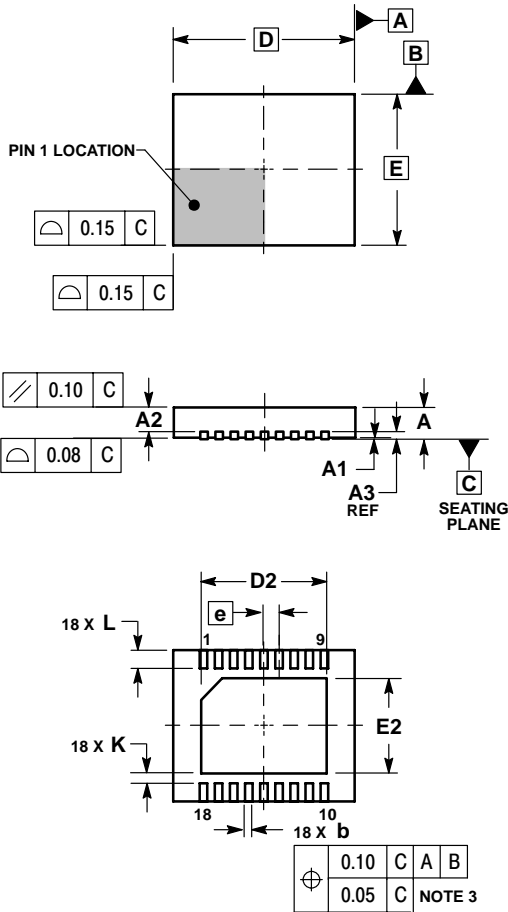

NOTES:

1. DIMENSIONS AND TOLERANCING PER ASME Y14.5M, 1994.
2. DIMENSIONS IN MILLIMETERS.
3. DIMENSION b APPLIES TO PLATED TERMINALS AND IS MEASURED BETWEEN 0.25 AND 0.30 MM FROM TERMINAL
4. COPLANARITY APPLIES TO THE EXPOSED PAD AS WELL AS THE TERMINALS.

MILLIMETERS		
DIM	MIN	MAX
A	0.80	1.00
A1	0.00	0.05
A2	0.65	0.75
A3	0.20 REF	
b	0.23	0.28
D	6.00 BSC	
D2	3.98	4.28
E	5.00 BSC	
E2	2.98	3.28
e	0.50 BSC	
K	0.20	---
L	0.50	0.60

ON Semiconductor and  are registered trademarks of Semiconductor Components Industries, LLC (SCILLC). SCILLC reserves the right to make changes without further notice to any products herein. SCILLC makes no warranty, representation or guarantee regarding the suitability of its products for any particular purpose, nor does SCILLC assume any liability arising out of the application or use of any product or circuit, and specifically disclaims any and all liability, including without limitation special, consequential or incidental damages. "Typical" parameters which may be provided in SCILLC data sheets and/or specifications can and do vary in different applications and actual performance may vary over time. All operating parameters, including "Typicals" must be validated for each customer application by customer's technical experts. SCILLC does not convey any license under its patent rights nor the rights of others. SCILLC products are not designed, intended, or authorized for use as components in systems intended for surgical implant into the body, or other applications intended to support or sustain life, or for any other application in which the failure of the SCILLC product could create a situation where personal injury or death may occur. Should Buyer purchase or use SCILLC products for any such unintended or unauthorized application, Buyer shall indemnify and hold SCILLC and its officers, employees, subsidiaries, affiliates, and distributors harmless against all claims, costs, damages, and expenses, and reasonable attorney fees arising out of, directly or indirectly, any claim of personal injury or death associated with such unintended or unauthorized use, even if such claim alleges that SCILLC was negligent regarding the design or manufacture of the part. SCILLC is an Equal Opportunity/Affirmative Action Employer.

PUBLICATION ORDERING INFORMATION

Literature Fulfillment:

Literature Distribution Center for ON Semiconductor
P.O. Box 5163, Denver, Colorado 80217 USA
Phone: 303-675-2175 or 800-344-3860 Toll Free USA/Canada
Fax: 303-675-2176 or 800-344-3867 Toll Free USA/Canada
Email: orderlit@onsemi.com

N. American Technical Support: 800-282-9855 Toll Free USA/Canada

JAPAN: ON Semiconductor, Japan Customer Focus Center
2-9-1 Kamimeguro, Meguro-ku, Tokyo, Japan 153-0051
Phone: 81-3-5773-3850

ON Semiconductor Website: <http://onsemi.com>

For additional information, please contact your local Sales Representative.