

LOW-VOLTAGE DC MOTOR SPEED CONTROLLER

- WIDE OPERATING VOLTAGE RANGE (1.8 to 6 V)
- BUILT-IN LOW-VOLTAGE REFERENCE (0.2 V)
- LINEARITY IN SPEED ADJUSTMENT
- HIGH STABILITY VS. TEMPERATURE
- LOW NUMBER OF EXTERNAL PARTS

DESCRIPTION

The TDA7274 is a monolithic integrated circuit DC motor speed controller intended for use in microcassettes, radio cassette players and other consumer equipment. It is particularly suitable for low-voltage applications.



PIN CONNECTION (top view)

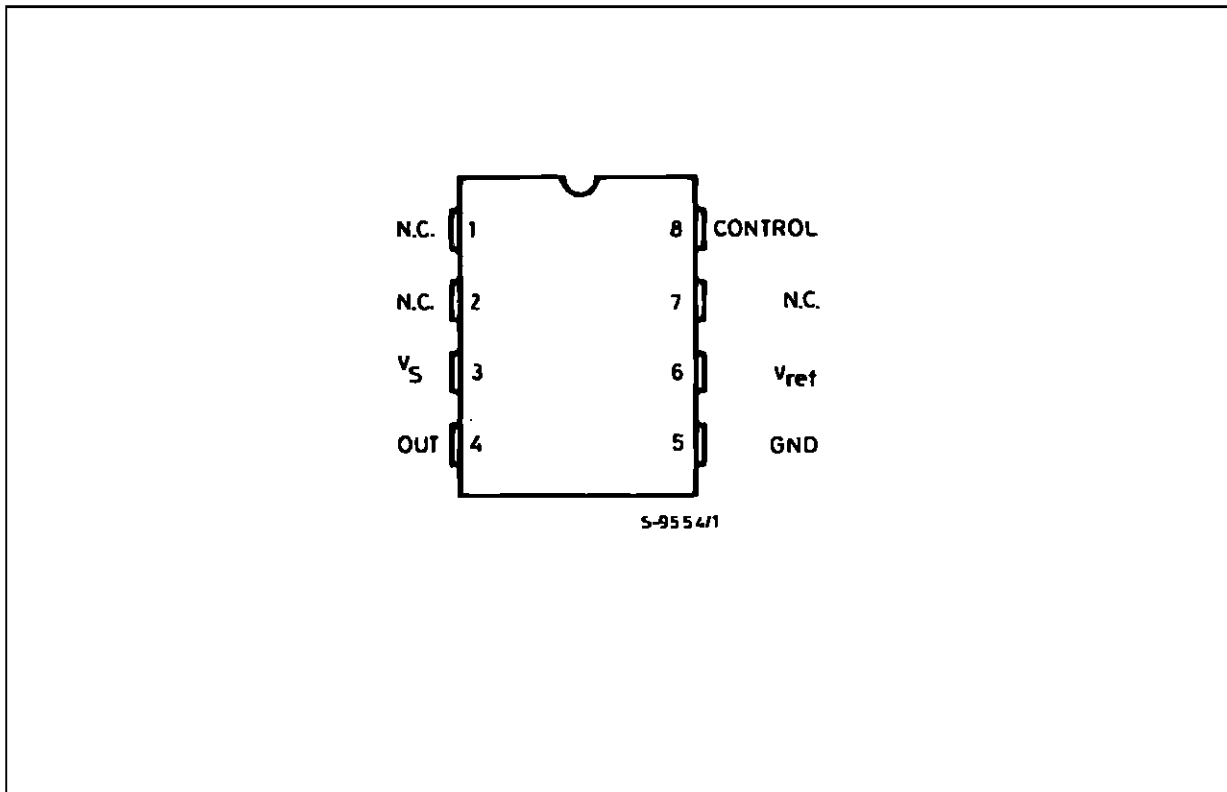

TDA7274

APPLICATION CIRCUIT

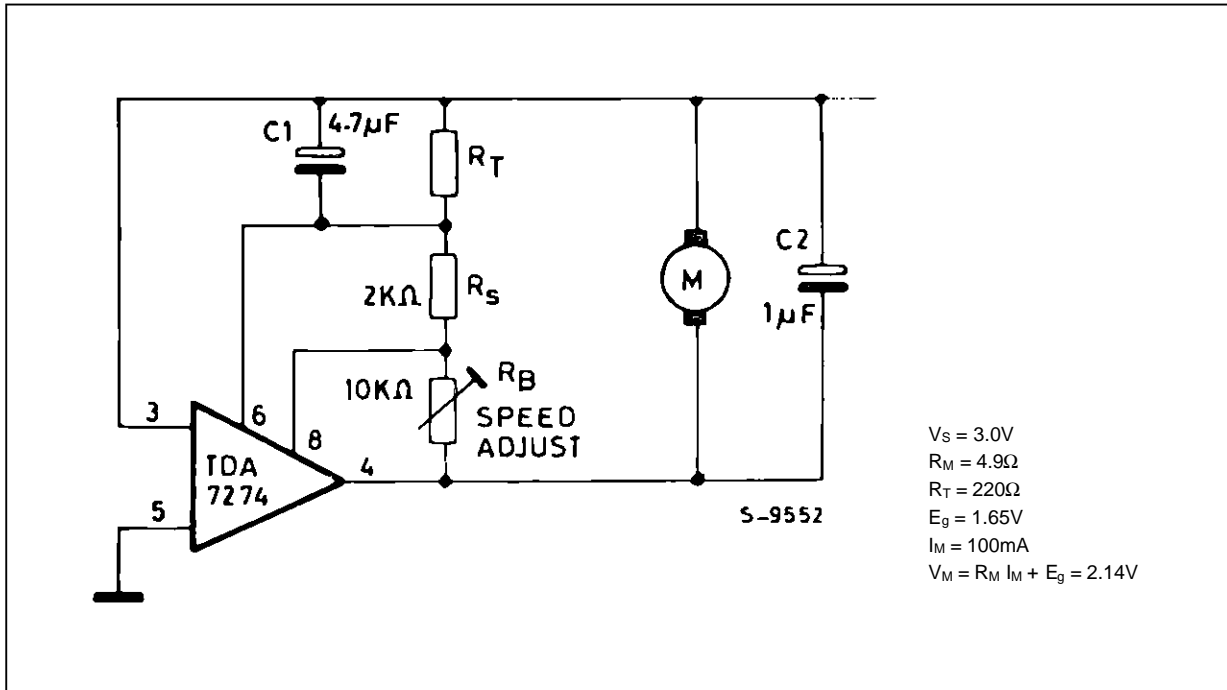

SCHEMATIC DIAGRAM

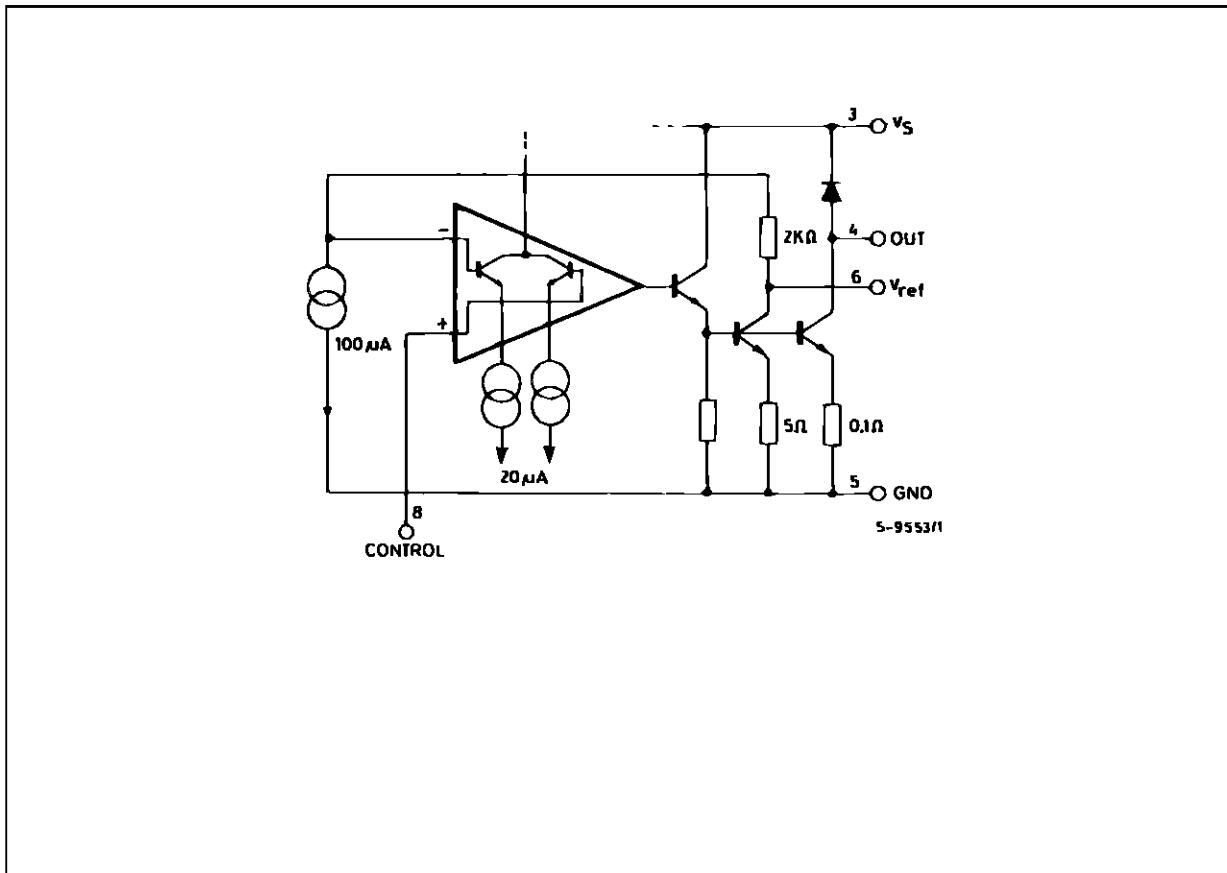

ABSOLUTE MAXIMUM RATINGS

Symbol	Parameter	Value	Unit
V_S	Supply Voltage	6	V
I_M	Motor Current	700	mA
P_{tot}	Power Dissipation at $T_{amb} = 25^\circ\text{C}$	1.25	W

THERMAL DATA

Symbol	Parameter	Value	Unit
$R_{th\ j-amb}$	Thermal Resistance Junction-ambient	Max. 100	$^\circ\text{C}/\text{W}$

ELECTRICAL CHARACTERISTICS (Refer to test circuit, $V_S = 3\text{V}$, $T_{amb} = 25^\circ\text{C}$ unless otherwise specified)

Symbol	Parameter	Test Condition	Min.	Typ.	Max.	Unit
V_S	Supply Voltage Range		1.8		6	V
V_{ref}	Reference Voltage	$I_M = 100\text{mA}$	0.18	0.20	0.22	V
I_q	Quiescent Current			2.4	6.0	mA
I_d (Pin 6)	Quiescent Current			120		μA
K	Shunt Ratio	$I_M = 100\text{mA}$	45	50	55	–
V_{sat}	Residual Voltage	$I_M = 100\text{mA}$		0.13	0.3	V
$\frac{\Delta V_{ref}}{V_{ref}} / \Delta V_S$	Line Regulation	$I_M = 100\text{mA}$ $V_S = 1.8$ to 6V		0.20		%/V
$\frac{\Delta K}{K} / \Delta V_S$	Voltage Characteristic of Shut Ratio	$I_M = 100\text{mA}$ $V_S = 1.8$ to 6V		0.80		%/V
$\frac{\Delta V_{ref}}{V_{ref}} / \Delta I_M$	Load Regulation	$I_M = 20$ to 200mA		0.004		%/mA
$\frac{\Delta K}{K} / \Delta I_M$	Current Characteristic of Shut Ratio	$I_M = 20$ to 200mA		–0.03		%/mA
$\frac{\Delta V_{ref}}{V_{ref}} / \Delta T_{amb}$	Temperature Characteristic of Reference Voltage	$I_M = 100\text{mA}$ $T_{amb} = -20$ to $+60^\circ\text{C}$		0.04		%/ $^\circ\text{C}$
$\frac{\Delta K}{K} / \Delta T_{amb}$	Temperature Characteristic of Shut Ratio	$I_M = 100\text{mA}$ $T_{amb} = 20$ to $+60^\circ\text{C}$		0.02		%/ $^\circ\text{C}$

TDA7274

Figure 1 : Test Circuit.

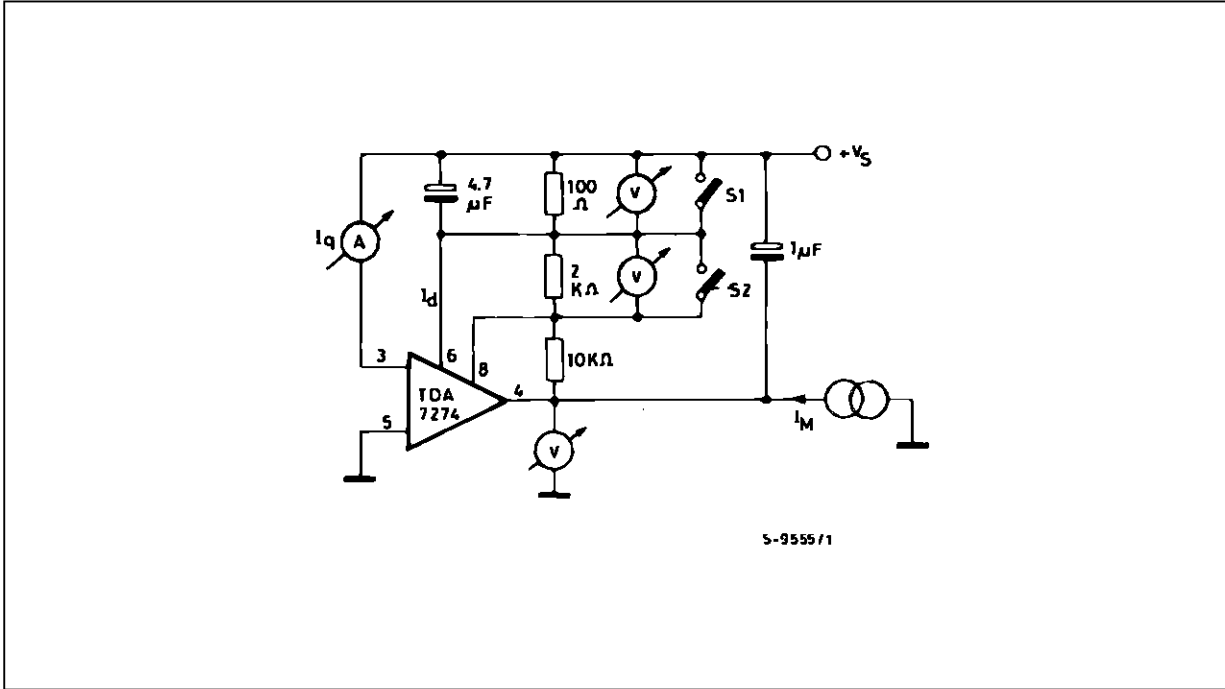

S-9555/1

Figure 2 : Quiescent Current vs. Supply Voltage.

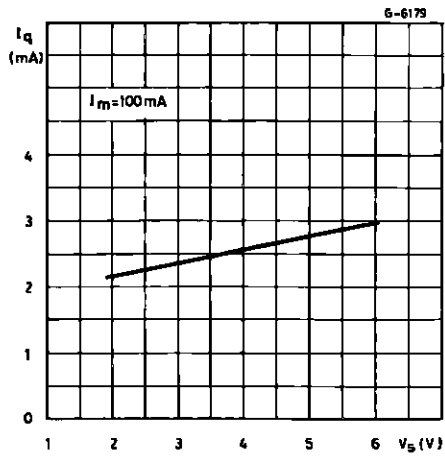

Figure 3 : Reference Voltage vs. Supply Voltage.

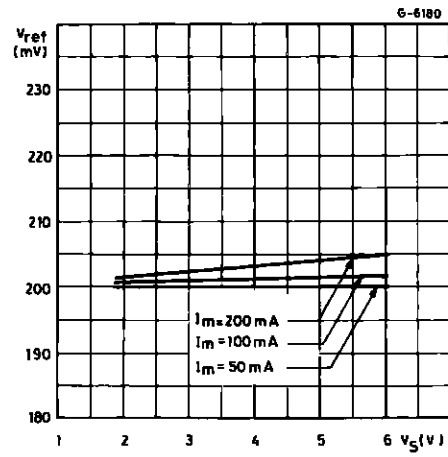

Figure 4 : Shunt Ratio vs. Supply Voltage.

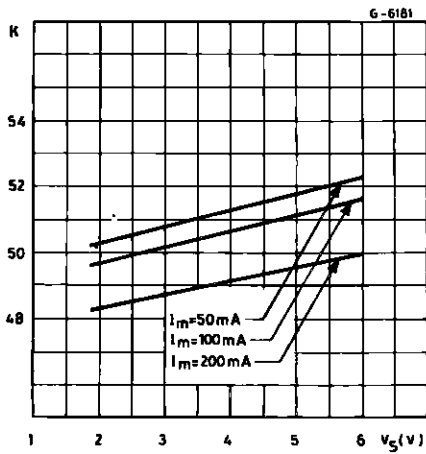

Figure 5 : Reference Voltage vs. Load Current.

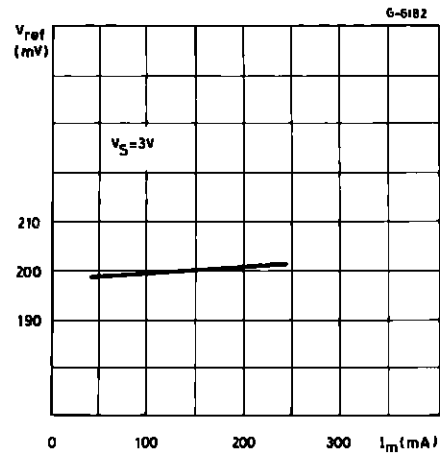

Figure 6 : Shunt Ratio vs. Load Current.

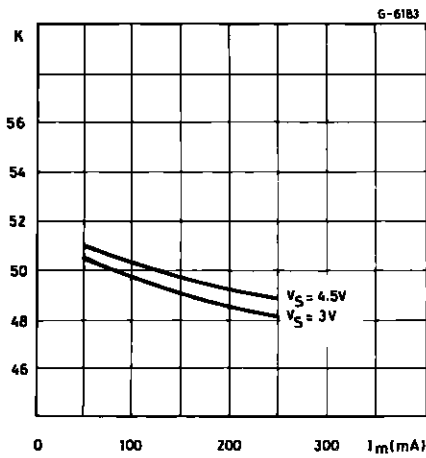

Figure 7 : Minimum Supply Voltage (typical) vs. Load Current.

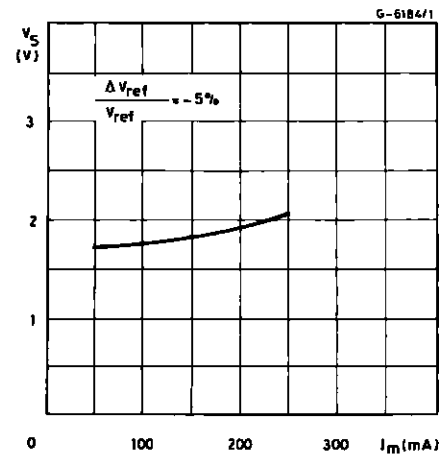

Figure 8 : Saturation Voltage vs. Load Current.

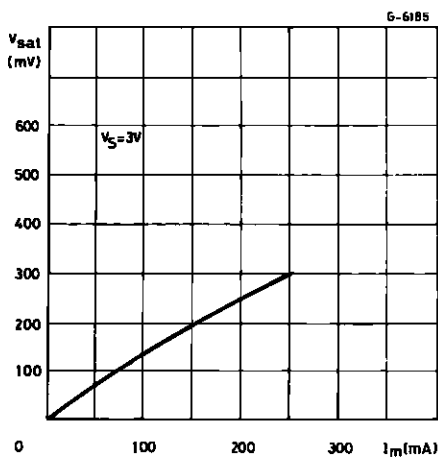

Figure 9 : Quiescent Current vs. Ambient Temperature.

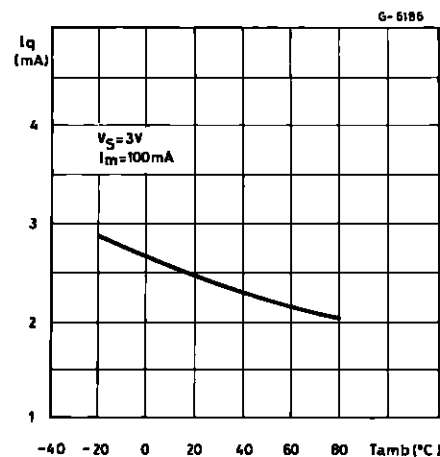

Figure 10 : Reference Voltage vs. Ambient Temperature.

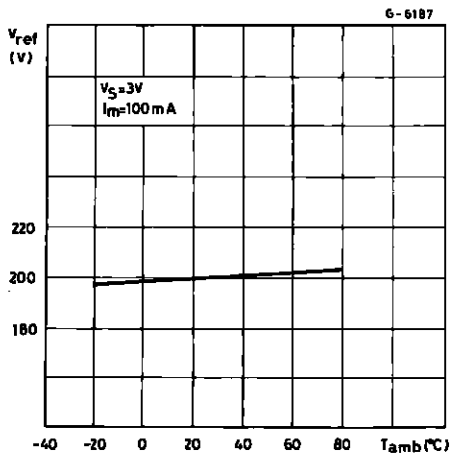

Figure 11 : Application Circuit.

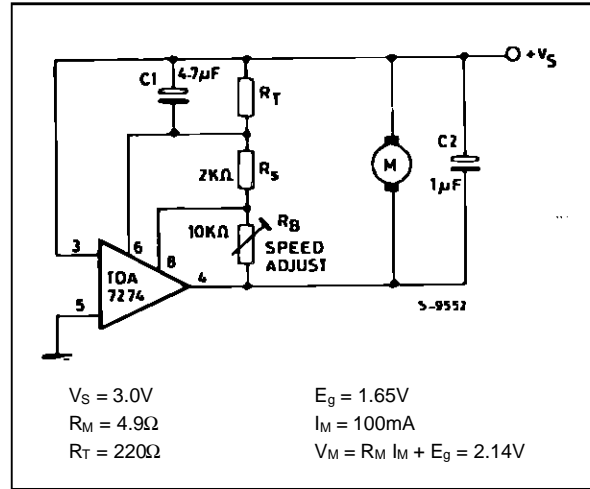

Figure 12 : P. C. Board and Components layout of the Circuit of fig. 11 (1 : 1 scale).

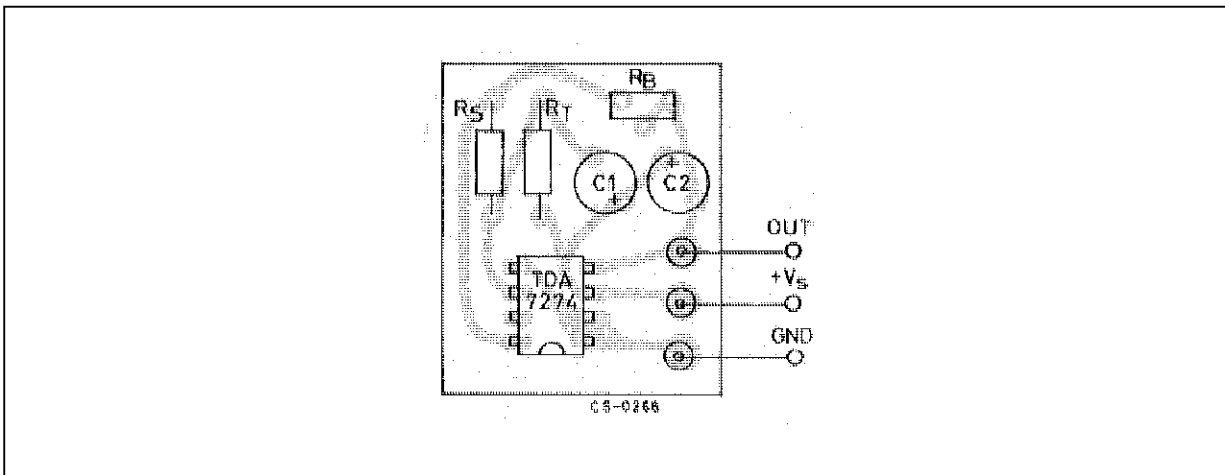

Figure 13 : Speed Variations vs. Supply Voltage.

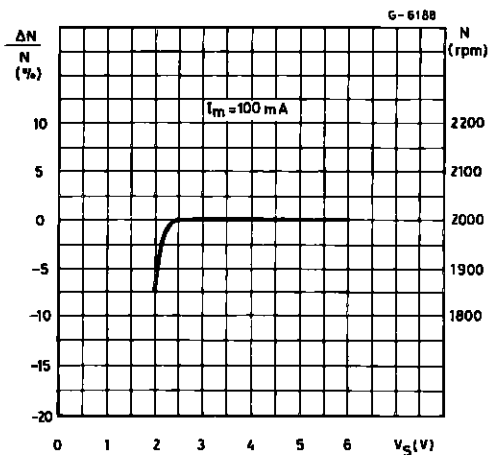

Figure 14 : Speed Variations vs. Motor Current.

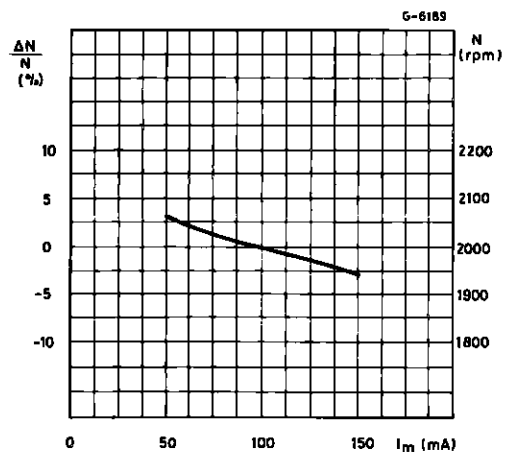
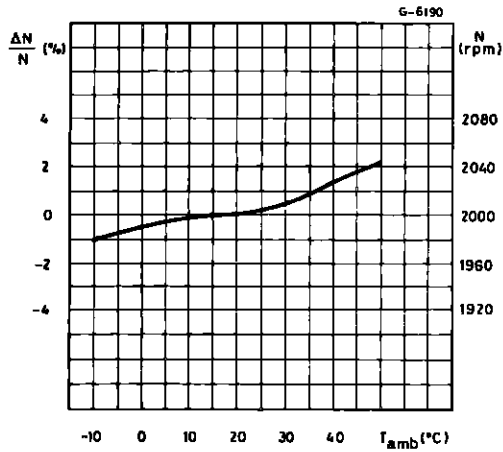
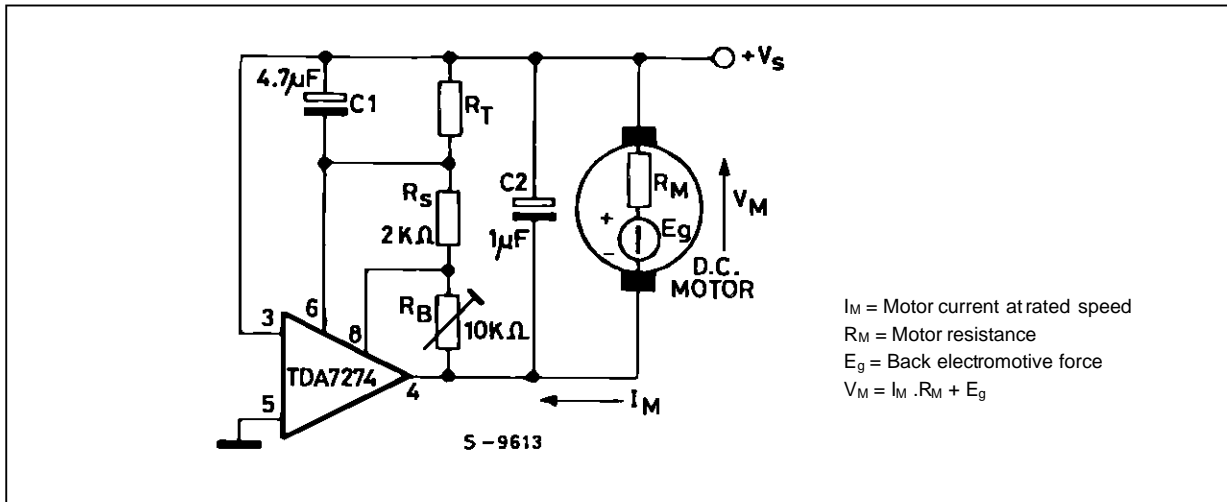

Figure 15 : Speed Variations vs. Ambient Temperature.



APPLICATION INFORMATION

Figure 16.



$$E_g = R_T I_d + I_M \left(\frac{R_T}{K} - R_M \right) + V_{ref}$$

$$\left[1 + \frac{R_B}{R_S} + \frac{R_T}{R_S} \left(1 + \frac{1}{K} \right) \right]$$

R_S has to be adjusted so that the applied voltage V_M is suitable for a given motor, the speed is then linearly adjustable varying R_B .

The value of R_T is calculated so that

$$R_{T(max.)} < K(min.) \cdot R_{M(min.)}$$

If $R_{T(max.)} > K \cdot R_M$, instability may occur.

The values of C_1 (4.7 μF typ.) and C_2 (1 μF typ.) depend on the type of motor used. C_1 adjusts motor spikes. C_2 suppresses motor spikes.

MINIDIP PACKAGE MECHANICAL DATA

DIM.	mm			inch		
	MIN.	TYP.	MAX.	MIN.	TYP.	MAX.
A		3.32			0.131	
a1	0.51			0.020		
B	1.15		1.65	0.045		0.065
b	0.356		0.55	0.014		0.022
b1	0.204		0.304	0.008		0.012
D			10.92			0.430
E	7.95		9.75	0.313		0.384
e		2.54			0.100	
e3		7.62			0.300	
e4		7.62			0.300	
F			6.6			0.260
I			5.08			0.200
L	3.18		3.81	0.125		0.150

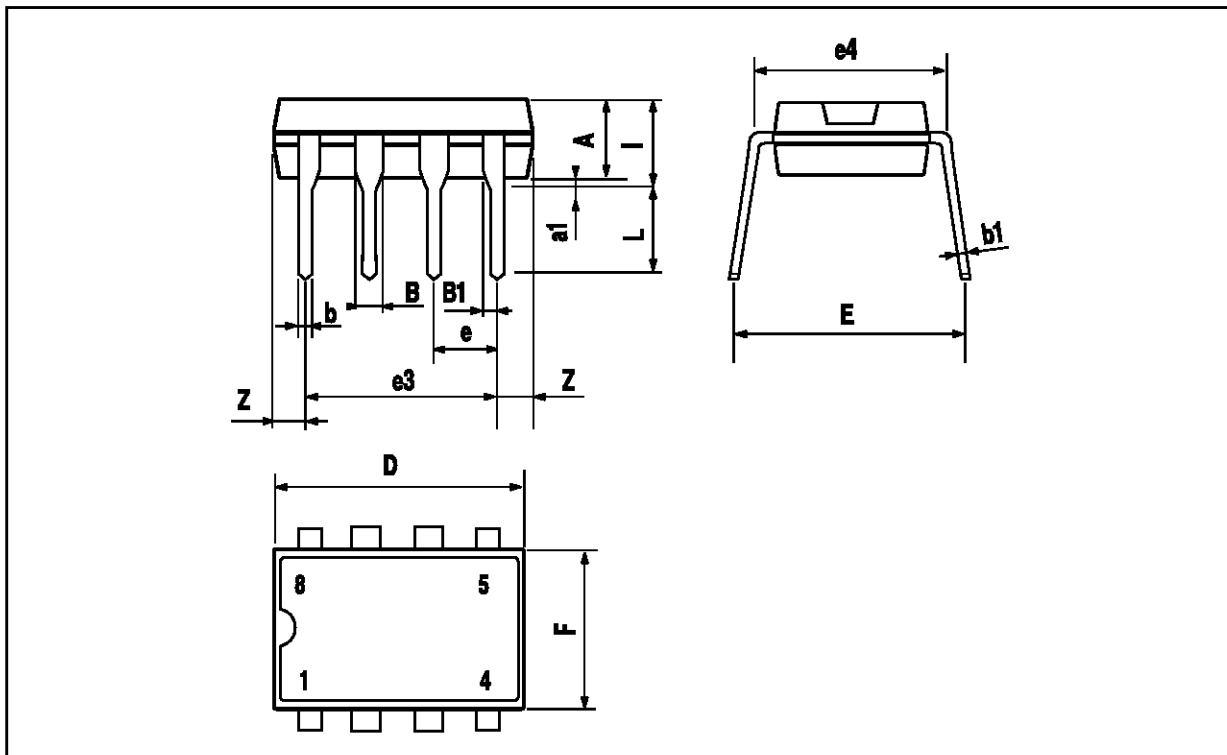

Information furnished is believed to be accurate and reliable. However, SGS-THOMSON Microelectronics assumes no responsibility for the consequences of use of such information nor for any infringement of patents or other rights of third parties which may result from its use. No license is granted by implication or otherwise under any patent or patent rights of SGS-THOMSON Microelectronics. Specifications mentioned in this publication are subject to change without notice. This publication supersedes and replaces all information previously supplied. SGS-THOMSON Microelectronics products are not authorized for use as critical components in life support devices or systems without express written approval of SGS-THOMSON Microelectronics.

© 1994 SGS-THOMSON Microelectronics - All Rights Reserved

SGS-THOMSON Microelectronics GROUP OF COMPANIES

Australia - Brazil - France - Germany - Hong Kong - Italy - Japan - Korea - Malaysia - Malta - Morocco - The Netherlands - Singapore - Spain - Sweden - Switzerland - Taiwan - Thailand - United Kingdom - U.S.A.