



**MOTOROLA**

# MCM2532

## 4096 × 8-BIT UV ERASABLE PROM

The MCM2532 is a 32,768-bit Erasable and Electrically Reprogrammable PROM designed for system debug usage and similar applications requiring nonvolatile memory that could be reprogrammed periodically. The transparent window in the package allows the memory content to be erased with ultraviolet light.

For ease of use, the device operates from a single power supply and has static power-down mode. Pin-for-pin compatible mask programmable ROMs are available for large volume production runs of systems initially using the MCM2532.

- Single +5 V Power Supply
- Organized as 4096 Bytes of 8 Bits
- Automatic Power-Down Mode (Standby)
- Fully Static Operation (No Clocks)
- TTL Compatible During Both Read and Program
- Maximum Access Time = 450 ns MCM2532
- Pin Compatible with MCM68A332 Mask Programmable ROMs
- Power MCM2532
  - Active — 150 mA Max
  - Standby — 25 mA Max

## MOS

(N-CHANNEL, SILICON-GATE)

## 4096 × 8-BIT UV ERASABLE PROM

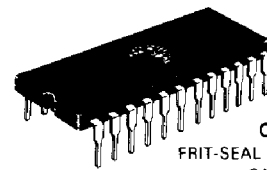

**C SUFFIX**  
FRIT-SEAL CERAMIC PACKAGE  
CASE 623A-02

### PIN ASSIGNMENT

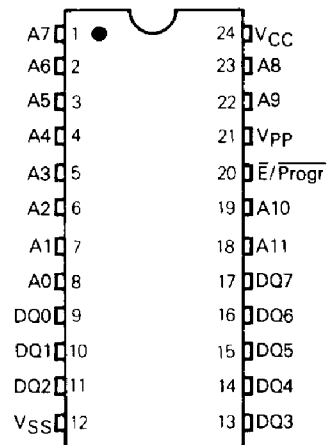

### MOTOROLA'S PIN-COMPATIBLE EPROM FAMILY

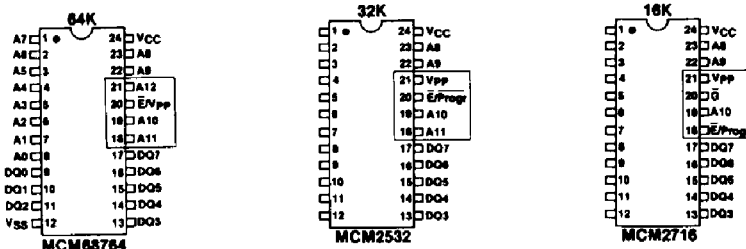

### MOTOROLA'S PIN-COMPATIBLE ROM FAMILY

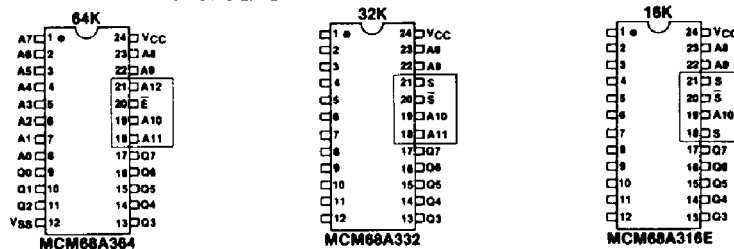

### INDUSTRY STANDARD PINOUTS

#### \*PIN NAMES

A..... Address  
DQ..... Data Input/Output  
E/Progr..... Dual Function Enable  
(Power-Down/Program Pulse)

\*New Industry standard nomenclature

EPODAM

**ABSOLUTE MAXIMUM RATINGS**

Rating	Value	Unit
Temperature Under Bias ( $V_{PP} = 5\text{ V}$ )	-10 to +80	°C
Operating Temperature Range	0 to +70	°C
Storage Temperature	-65 to +125	°C
All Input/Output Voltages with Respect to $V_{SS}$	+6 to -0.3	V
$V_{PP}$ Supply Voltage with Respect to $V_{SS}$	+28 to -0.3	V

This device contains circuitry to protect the inputs against damage due to high static voltages or electric fields; however, it is advised that normal precautions be taken to avoid application of any voltage higher than maximum rated voltages to this high-impedance circuit.

NOTE: Permanent device damage may occur if ABSOLUTE MAXIMUM RATINGS are exceeded. Functional operation should be restricted to RECOMMENDED OPERATING CONDITIONS. Exposure to higher than recommended voltages for extended periods of time could affect device reliability.

**MODE SELECTION**

Mode	Pin Number				
	9-11, 13-17 DQ	12 $V_{SS}$	20 $\bar{E}/\text{Progr}$	21 $V_{PP}$	24 $V_{CC}$
Read	Data Out	$V_{SS}$	$V_{IL}$	5 V	$V_{CC}$
Output Disable	High Z	$V_{SS}$	$V_{IH}$	5 to 25 V	$V_{CC}$
Standby	High Z	$V_{SS}$	$V_{IH}$	5 V	$V_{CC}$
Program	Data In	$V_{SS}$	Pulsed $V_{IH}$ to $V_{IL}$	$V_{PPH}$	$V_{CC}$
Program Verify	Data Out	$V_{SS}$	$V_{IL}$	5 V	$V_{CC}$
Program Inhibit	High Z	$V_{SS}$	$V_{IH}$	$V_{PPH}$	$V_{CC}$

EPROM

**BLOCK DIAGRAM**

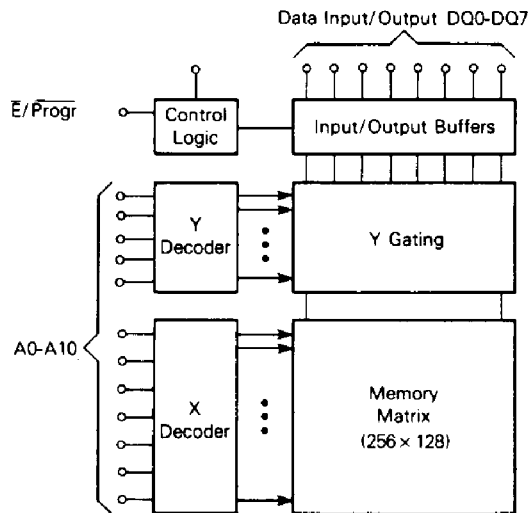

**FIGURE 1 — AC TEST LOAD**

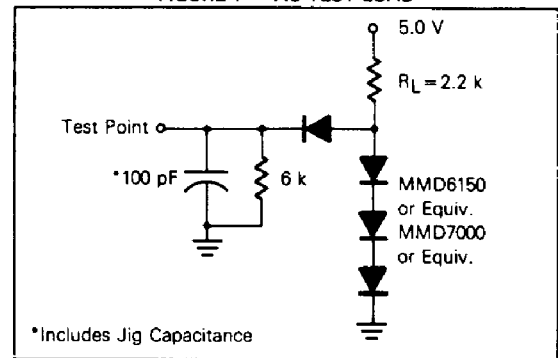

CAPACITANCE (f = 1.0 MHz, T<sub>A</sub> = 25°C, periodically sampled rather than 100% tested.)

Characteristic	Symbol	Typ	Max	Unit
Input Capacitance (V <sub>in</sub> = 0 V)	C <sub>in</sub>	4.0	6.0	pF
Output Capacitance (V <sub>out</sub> = 0 V)	C <sub>out</sub>	8.0	12	pF

Capacitance measured with a Boonton Meter or effective capacitance calculated from the equation: C = IΔt/ΔV.

**DC OPERATING CONDITIONS AND CHARACTERISTICS**  
(Fully operating voltage and temperature range unless otherwise noted)

**RECOMMENDED DC OPERATING CONDITIONS**

Parameter	Symbol	Min	Typ	Max	Unit
Supply Voltage*	V <sub>CC</sub>	4.75	5.0	5.25	V
	V <sub>pp</sub>	4.75	5.0	5.25	
Input High Voltage	V <sub>IH</sub>	2.2	–	V <sub>CC</sub> + 1.0	V
Input Low Voltage	V <sub>IL</sub>	–0.1	–	0.65	V

**RECOMMENDED DC OPERATING CHARACTERISTICS**

Characteristic	Condition	Symbol	Min	Max	Unit
Address and $\bar{E}$ Input Sink Current	V <sub>in</sub> = 5.25 V	I <sub>in</sub>	–	10	μA
Output Leakage Current	V <sub>out</sub> = 5.25 V	I <sub>LO</sub>	–	10	μA
V <sub>CC</sub> Supply Current* (Standby)	MCM2532 $\bar{E} = V_{IH}$	I <sub>CC1</sub>	–	25	mA
V <sub>CC</sub> Supply Current* (Active)	MCM2532 $\bar{E} = V_{IL}$	I <sub>CC2</sub>	–	150	mA
V <sub>pp</sub> Supply Current*	V <sub>pp</sub> = 5.25 V	I <sub>pp1</sub>	–	5.0	mA
Output Low Voltage	I <sub>OL</sub> = 2.1 mA	V <sub>OL</sub>	–	0.45	V
Output High Voltage	I <sub>OH</sub> = –400 μA	V <sub>OH</sub>	2.4	–	V

\*V<sub>CC</sub> must be applied simultaneously or prior to V<sub>pp</sub>. V<sub>CC</sub> must also be switched off simultaneously with or after V<sub>pp</sub>. With V<sub>pp</sub> connected directly to V<sub>CC</sub> during the read operation, the supply current would be the sum of I<sub>pp1</sub> and I<sub>CC</sub>.

**AC READ OPERATING CONDITIONS AND CHARACTERISTICS**  
(Full Operating Voltage and Temperature Range Unless Otherwise Noted)

Input Pulse Levels..... 0.65 Volt and 2.2 Volts      Input and Output Timing Levels..... 0.8 and 2.0 Volts  
Input Rise and Fall Times..... 20 ns      Output Load..... See Figure 1

Characteristic	Symbol	Min	Max	Unit
Address Valid to Output Valid ( $\bar{E}/\text{Progr} = V_{IL}$ )	t <sub>AVOQ</sub>	–	450	ns
$\bar{E}$ to Output Valid	t <sub>ELQV</sub>	–	450	ns
$\bar{E}$ to High Z Output	t <sub>EHQZ</sub>	0	100	ns
Data Hold from Address ( $\bar{E} = V_{IL}$ )	t <sub>AXQX</sub>	0	–	ns

READ MODE TIMING DIAGRAMS ( $\bar{E} = V_{IL}$ )

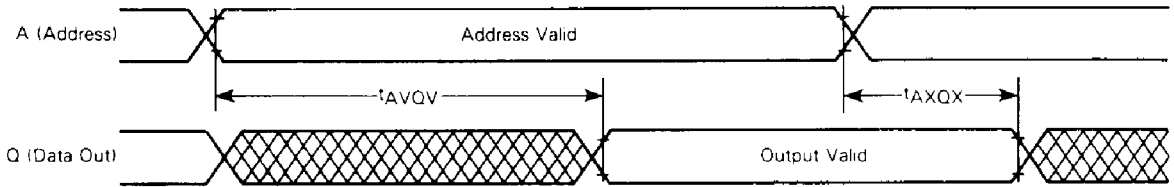

STANDBY MODE

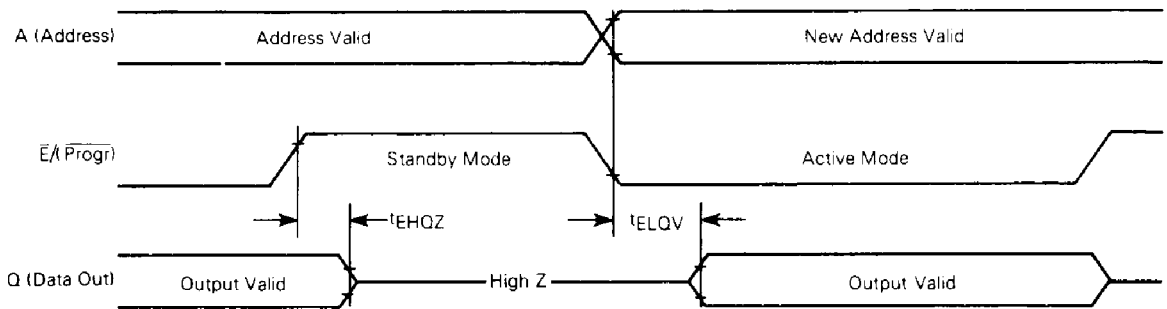

DC PROGRAMMING CONDITIONS AND CHARACTERISTICS

( $T_A = 25^\circ\text{C} \pm 5^\circ\text{C}$ )

RECOMMENDED PROGRAMMING OPERATION CONDITIONS

Parameter	Symbol	Min	Nom	Max	Unit
Supply Voltage	$V_{CC}, V_{PPL}, V_{PPH}$	4.75 24	5.0 25	5.25 26	v
Input High Voltage for Data	$V_{IH}$	2.2	—	$V_{CC} + 1$	v
Input Low Voltage for Data	$V_{IL}$	-0.1	—	0.65	v

\* $V_{CC}$  must be applied simultaneously or prior to  $V_{PP}$ .  $V_{CC}$  must also be switched off simultaneously with or after  $V_{PP}$ . The device must not be inserted into or removed from a board with  $V_{PP}$  at +25 V.  $V_{PP}$  must not exceed the +26 V maximum specifications.

PROGRAMMING OPERATION DC CHARACTERISTICS

Characteristic	Condition	Symbol	Min	Typ	Max	Unit
Address and $\bar{E}/\text{Progr}$ Input Sink Current	$V_{in} = 5.25 \text{ V}/0.45 \text{ V}$	$I_{LI}$	—	—	10	$\mu\text{A}$
$V_{PP}$ Programming Pulse Supply Current ( $V_{PP} = 25 \text{ V} \pm 1 \text{ V}$ )	$\bar{E}/\text{Progr} = V_{IL}$	$i_{PP2}$	—	—	30	mA
$V_{CC}$ Supply Current – MCM2532	—	$i_{CC}$	—	—	160	mA

AC PROGRAMMING OPERATING CONDITIONS AND CHARACTERISTICS

Characteristic	Symbol	Min	Max	Unit
Address Setup Time	$t_{AVEL}$	2.0	—	$\mu\text{s}$
$V_{PP}$ Setup Time	$t_{PHEL}$	0	—	ns
Data Setup Time	$t_{DVEL}$	2.0	—	$\mu\text{s}$
Address Hold Time	$t_{EHAX}$	2.0	—	$\mu\text{s}$
$V_{PP}$ to Enable Low Time	$t_{PLEL}$	0	—	ns
Data Hold Time	$t_{EHOZ}$	2.0	—	$\mu\text{s}$
$V_{PP}$ Hold Time	$t_{EHPL}$	0	—	ns
Enable (Program) Active Time	$t_{ELEH}$	1*	55	ms
Enable ( $\bar{E}/\text{Progr}$ ) Pulse Transition Time	$t_{T(PE)}$	5	—	ns
$V_{PP}$ Rise and Fall Time from 5 to 25 V	$t_R, t_F$	0.5	2	$\mu\text{s}$

\*If shorter than 45 ms (min) pulses are used, the same number of pulses should be applied after the specific data has been verified. To ensure that good programming levels have been written, see special programming.

EPROM

PROGRAMMING OPERATION TIMING DIAGRAM

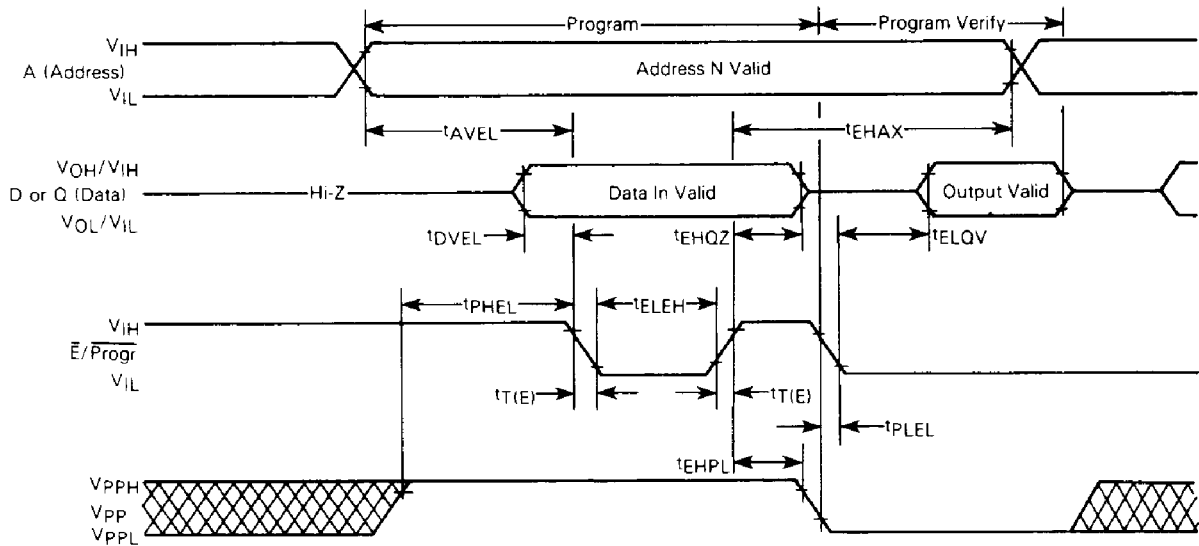

PROGRAMMING INSTRUCTIONS

Before programming, the memory should be submitted to a full ERASE operation to ensure every bit in the device is in the "1" state (represented by Output High). Data are entered by programming zeros (Output Low) into the required bits. The words are addressed the same way as in the READ operation. A programmed "0" can only be changed to a "1" by ultraviolet light erasure.

To set the memory up for PROGRAM mode, the VPP input (pin 21) should be raised to +25 V. The VCC supply voltage is the same as for the READ operation. Programming data is entered in 8-bit words through the data out (DQ) terminals while  $\bar{E}/\text{Progr}$  is high. Only "0's" will be programmed when "0's" and "1's" are entered in the data word.

After address and data setup, a 50 ms program pulse ( $V_{IH}$  to  $V_{IL}$ ) is applied to the  $\bar{E}/\text{Progr}$  input. A program pulse is applied to each address location to be programmed. The maximum program pulse width is 55 ms; therefore, programming must not be attempted with a dc signal applied to the  $\bar{E}/\text{Progr}$  input.

Multiple MCM2532s may be programmed in parallel with the same data by connecting together like inputs and applying the program pulse to the  $\bar{E}/\text{Progr}$  inputs. Different data may be programmed into multiple MCM2532s connected in parallel by using the PROGRAM INHIBIT mode. Except for the  $\bar{E}/\text{Progr}$  pin, all like inputs may be common.

PROGRAM VERIFY for the MCM2532 is the read operation.

SPECIAL PROGRAMMING

The MCM2532 can be programmed with pulses as short as 2 milliseconds to minimize programming time. This can represent considerable cost savings when programming a large number of devices.

To take full advantage of the shorter programming pulses, an iterative algorithm is recommended. Actual programming algorithms can be varied provided the following conditions are met: 1) Program pulses will be applied one to each sequential location (no multiple pulses at one location); and 2) after the part programs successfully, five additional 2 millisecond pulses should be applied at each location.

Using this iterative method, the programming time per location becomes 12 milliseconds minimum to 50 milliseconds maximum.

READ OPERATION

After access time, data is valid at the outputs in the READ mode.

ERASING INSTRUCTIONS

The MCM2532 can be erased by exposure to high intensity shortwave ultraviolet light, with a wave-length of 2537 angstroms. The recommended integrated dose (i.e., UV-intensity X exposure time) is 15 Ws/cm<sup>2</sup>. As an example, using the "Model 30-000" UV-Eraser Turner Designs, Mountain View, CA 94043) the ERASE-time is 36 minutes. The lamps should be used without shortwave filters and the MCM2532 should be positioned about one inch away from the UV-tubes.

RECOMMENDED OPERATING PROCEDURES

After erasure and reprogramming of the EPROM, it is recommended that the quartz window be covered with an opaque self-adhesive cover. It is important that the self-adhesive cover not leave any residue on the quartz if it is removed to allow another erasure.

EPROM

**TIMING PARAMETER ABBREVIATIONS**

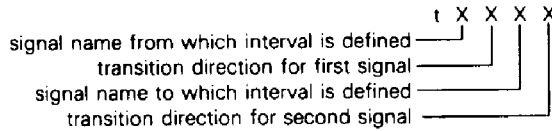

The transition definitions used in this data sheet are:

- H = transition to high
- L = transition to low
- V = transition to valid
- X = transition to invalid or don't care
- Z = transition to off (high impedance)

**TIMING LIMITS**

The table of timing values shows either a minimum or a maximum limit for each parameter. Input requirements are specified from the external system point of view. Thus, address setup time is shown as a minimum since the system must supply at least that much time (even though most devices do not require it). On the other hand, responses from the memory are specified from the device point of view. Thus, the access time is shown as a maximum since the device never provides data later than that time.

**WAVEFORMS**

Waveform Symbol	Input	Output
	Must Be Valid	Will Be Valid
	Change From H to L	Will Change From H to L
	Change From L to H	Will Change From L to H
	Don't Care: Any Change Permitted	Changing State Unknown
		High Impedance

EPROM